

# Prior

**QUALITY AND SERVICE FOR OVER 70 YEARS**

[www.priorautomotive.com](http://www.priorautomotive.com)

## **AIR BRAKE PRODUCTS**

**REMANUFACTURED FOR HEAVY DUTY TRUCKS AND BUSES**



## **HYDRO-VAC / HYDRO-MAX / HY POWER**

**REMANUFACTURED FOR MEDIUM DUTY TRUCKS AND BUSES**

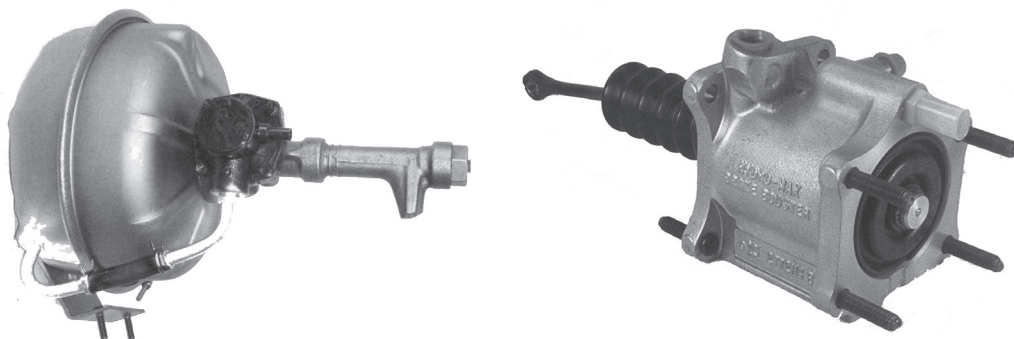

---

---

# Prior Automotive Products, LLC

[www.priorautomotive.com](http://www.priorautomotive.com)

Phone: 972-388-1090

Fax: 972-388-1095

## SERVICE

FULL TIME TECH SERVICE STAFF.

QUICK STOCK ORDER TURNAROUND.

SPECIAL ORDERS SHIPPED SAME DAY.

## QUALITY

100% OF UNITS TESTED.

ONE OF THE LARGEST QUALITY ASSURANCE STAFFS IN THE INDUSTRY.

CONTINUOUS EMPLOYEE INVOLVEMENT

## DEPENDABILITY

- QUALITY REMANUFACTURED BRAKE PRODUCTS SINCE 1951.
- HIGHEST STANDARDS OF PRECISION REMANUFACTURING.
- ONE DAY SERVICE OF SPECIAL ORDERS.
- FULL TIME TECHNICAL STAFF AVAILABLE TO ASSIST YOU.



**CENTRALLY LOCATED IN DALLAS COUNTY, TEXAS**

---

---

# PRIOR AUTOMOTIVE PRODUCTS, LLC

## TABLE OF CONTENTS

NOTICE: ALL MANUFACTURERS NAMES, NUMBERS, SYMBOLS, AND DESCRIPTIONS ARE USED IN THIS CATALOG FOR REFERENCE PURPOSES ONLY AND IT IS NOT IMPLIED THAT ANY PART LISTED IS THE PRODUCT OF THESE MANUFACTURERS.

	PAGE
Numerical Listing and Interchange .....	4
O.E.M. Dealer to Prior Interchange .....	45

### PICTURES

Compressors .....	51
Air Dryers .....	63
Midland Pressure Converters .....	71
Governors & Foot Valves .....	72
Dash - PP Valves .....	74
Relay Valves .....	76-82
Bendix Tractor & Trailer Control Valves .....	83
Spring Brake Valves - Bendix & Sealco .....	84-85
Tractor Protection Valves .....	86
Quick Release Valves .....	87
Pressure Protection - Inversion - Drain Valves .....	88
Check Valves .....	89
Stop Light Switches .....	90
Fuller/Neway/Wagner Misc. Valves .....	91-92

### MEDIUM DUTY TRUCK SECTION

Warranty Policy .....	94
Vehicle Application Data .....	95-141
Pictures, Drawings, & Identification .....	142-154
Numerical List .....	155-160

# PRIOR AUTOMOTIVE PRODUCTS, LLC

## LIMITED WARRANTY POLICY

### AIR BRAKE PRODUCTS

This warranty has been drafted to comply with Federal rules issued under the Magnuson-Moss Warranty Act applicable to products manufactured after December 31, 1976.

**WARRANTY COVERAGE:** This remanufactured unit is warranted against defective materials or workmanship. **THIS WARRANTY IS VOID IF: THE UNIT HAS BEEN DAMAGED BY ACCIDENT OR UNREASONABLE USE, NEGLIGENCE, IMPROPER SERVICE OR OTHER CAUSES NOT ARISING OUT OF DEFECTS IN MATERIALS OR WORKMANSHIP.**

**WARRANTY PERFORMANCE:** During the warranty period the unit will either be repaired or replaced (at our option) with a remanufactured model of an equivalent quality when the unit is returned, postage prepaid and insured to our facility. In the event of replacement with a remanufactured model the replacement unit will provide a new warranty.

PRIOR REMANUFACTURING, INC. warrants to the original purchaser that all products will be free of defective materials and workmanship for the following time periods and mileage durations.

	MONTHS	MILEAGE	KILOMETERS	HOURS
AIR COMPRESSORS (ALL SERIES AND MODELS)	24	200,000	320,000	7,200
AIR VALVES (ALL SERIES AND MODELS)	24	200,000	320,000	7,200
SPRING BRAKES (ALL SERIES AND MODELS)	24	200,000	320,000	7,200
ALL OTHER PRIOR REMANUFACTURING, INC. AIR BRAKE PRODUCTS	24	200,000	320,000	7,200

**WARRANTY DISCLAIMERS:** WITH RESPECT TO CONSUMER USE OF THE UNIT, ANY IMPLIED WARRANTIES WHICH THE CONSUMER MAY HAVE ARE LIMITED IN DURATION TO THE ABOVE 24 MONTH / 200,000 MILE PERIOD. WITH RESPECT TO COMMERCIAL AND INDUSTRIAL USES OF THE UNIT, THE FOREGOING WARRANTY IS IN LIEU OF AND EXCLUDES ALL OTHER WARRANTIES, WHETHER EXPRESSED OR IMPLIED, BY OPERATION OF LAW OR OTHERWISE, INCLUDING, BUT NOT LIMITED TO, ANY IMPLIED WARRANTY OR MERCHANTABILITY OR FITNESS FOR A PARTICULAR PURPOSE. TO THE EXTENT ALLOWED BY LAW, THE COMPANY SHALL NOT BE LIABLE FOR LOSS OF USE OF THE UNIT OR OTHER INCIDENTAL OR CONSEQUENTIAL COST, EXPENSES, OR DAMAGES INCURRED BY THE PURCHASER.

Some states do not allow the exclusion or limitation of implied warranties, incidental or consequential damages, so the above limitations or exclusions may not apply to you.

**Legal Remedies:** This warranty gives you specific legal rights, and you may also have other rights that vary from state to state.

# **MATERIALS RETURN POLICY**

## **CORE RETURNS:**

Core credits are issued based on eligibility for units purchased within the previous six months. Core credit will not be issued for any units returned in excess of purchases. Customer will be notified of units returned in excess of purchases and will be returned if requested. Any excess units held for six months after notification will be scrapped or sold for storage costs. All Core Returns should be properly marked and have sufficient paper work to assure correct credit. All Cores are to be returned in the Original Box to receive credit.

Units purchased as complete (Booster with Master Cylinder) must be returned with the booster and master cylinder attached to receive credit.

The following are not acceptable for credit or exchange:

- Badly rusted or corroded from the lack of use or neglect.
- Units not shown in our catalog or price lists.
- Wrecked or burned units.

Cores should be sent in less connections, fittings, air cleaners, mounting brackets (except some General Motors applications, where the units may have brackets riveted on).

Exchange prices are based on wear and do not cover missing, broken, or damaged parts; such as end plates, housings, shells, cans, tubes, etc. Charges for broken or missing parts are shown on the back page of the price sheet.

To ensure that the proper freight discounts can be utilized, the Bill Of Lading should be filled out as follows:

<b>QTY</b>	<b>DESCRIPTION</b>	<b>WEIGHT</b>
<b>(NO.)</b>	<b>(Pallet, Skid, Carton...etc.)</b>	<b>(Lbs.)</b>
<b>CASTINGS IN THE ROUGH</b> <b>CLASS 50 ITEM NO. 104780 SUB. 3</b>		

**NOTE: ALL FREIGHT SHOULD BE SENT IN FREIGHT COLLECT. YOUR SHIPMENT SHOULD WEIGH 200 POUNDS OR MORE TO RECEIVE FREIGHT CREDIT.** Your cooperation will enable us to keep our freight costs to a minimum and avoid charge backs for shipments due to weights below the minimum or higher class rate charges we incur related to improperly completed Bills Of Lading.

**No other information** such as "used auto parts" or "brake castings" should be on the Bill Of Lading. This can be interpreted as another item number and classed at a higher rate.

**PLEASE FORWARD THIS INFORMATION TO ALL PERSONS RESPONSIBLE FOR COMPLETING THE FREIGHT BILLS FOR CORE RETURN SHIPMENTS.**

## **WARRANTY RETURNS:**

Units returned for warranty credit are to be tagged with reason for return marked. Warranty Units can be returned with a regular shipment of old cores but should be listed on a separate packing list.

Our warranty does not apply when units have been disassembled, improperly installed, improperly maintained, or repaired by anyone other than authorized personnel at our factory. Our warranty does not cover labor claims or other charges. See detailed Warranty Policy in front of catalog.

# PRIOR AUTOMOTIVE PRODUCTS, LLC

## NUMERICAL LISTING AND INTERCHANGE

PART NO.	PAGE NO.	PICTURE REF.	DESCRIPTION OR INTERCHANGE NO. (H)-HEAD (B)-BLOCK (R)-RIGHT (L)-LEFT	PART NO.	PAGE NO.	PICTURE REF.	DESCRIPTION OR INTERCHANGE NO. (H)-HEAD (B)-BLOCK (R)-RIGHT (L)-LEFT
A1000	77	156	Sealco Relay	EL13081		USE	N7008A (H-R B-R)
A104001-N	77	155	SR4 SPR BRK VAL	EL13090		USE	N7009 (H-R B-R)
A32917		USE	278597	EL13090		USE	N7009E (H-L B-R)
A32940		USE	278597	EL13100		USE	N7010 (H-R B-R)
A3546-N	87	236	Fuller Shift Valve	EL13100		USE	N7010A (H-L B-R)
A42122		USE	278598	EL13100		USE	NT7010F (H-R B-R)
A43755		USE	278596	EL13111		USE	N7011 (H-L B-L)
A4490	87	238	NEW Fuller Air Valve	EL13112		USE	N7011 (H-L B-L)
A46229		USE	A71890	EL13120		USE	NT7012B (H-R B-R)
A4688-N	87	239	Fuller Slave Valve	EL13120		USE	N7012A (H-R B-R)
A48370		USE	A80270	EL13140		USE	N7014B (H-R B-R)
A4900-N	87	240	Fuller Range Valve	EL13150		USE	N7015 (H-R B-R)
A5010-N	87	241	Fuller Range Valve	EL13151		USE	NT7015A (H-R B-R)
A5015-N	88	242	Fuller Range Valve	EL13160		USE	N7016 (H-L B-R)
A56440		USE	A78880	EL13170		USE	N7017 (H-R B-R)
A6909-N	88	243	Fuller Range Valve	EL13170		USE	NT7017 (H-R B-R)
A6913-N	88	244	Fuller Range Valve	EL13200		USE	N7020 (H-R B-R)
A6915-N	88	245	Fuller Range Valve	EL13200		USE	NT7020 (H-R B-R)
A6918-N	88	246	Fuller Range Valve	EL13220		USE	NT7022E (H-R B-R)
A71890-N	77	157	Wagner Eme Relay	EL13260		USE	N7026 (H-R B-R)
A71891-N	77	157	Wagner Eme Relay	EL13280		USE	NT7028C (H-R B-R)
A71892		USE	A71891	EL13300		USE	NT7030 (H-R B-R)
A78880-N	76	145	RG2 Wagner Relay	EL13301		USE	NT7030 (H-R B-R)
A78882		USE	A78889	EL13312		USE	NT7031B (H-L B-L)
A78886-N	76	145	RG2 Wagner Relay	EL13330		USE	NT7033D (H-R B-R)
A78887-N	76	145	RG2 Wagner Relay	EL14050		USE	NT7305 (H-R B-R)
A78889-N	76	145	RG2 Wagner Relay	EL14051		USE	NT7305A (H-L B-R)
A86310		USE	A78886	EL14111		USE	N7311 (H-L B-R)
A86311		USE	A78886	EL16020		USE	N7202H (H-R B-L)
A86313		USE	A78889	EL16020		USE	N7202A (H-R B-R)
A86314-N	76	145	RG2 Wagner Relay	EL16020		USE	NT7202G (H-L B-L)
A86318		USE	A78889	EL16040		USE	NT7204 (H-R B-R)
A97926		USE	A78880	EL16040		USE	N7204 (H-R B-R)
A97927		USE	A78887	EL16050		USE	N7205 (H-R B-R)
A98731		USE	A98730	EL16050		USE	N7205B (H-R B-L)
A98732		USE	A98730	EL16050		USE	N7205D (H-L B-R)
A99036-N	77	157	Relay Em. Valve	EL16051		USE	N7205P (H-L B-L)
AD80150		USE	A80150	EL16051		USE	NT7205V (H-R B-L)
AR10650		USE	3049186	EL16052		USE	NT7205F (H-R B-R)
AR11952		USE	3049186	EL16052		USE	NT7205P (H-L B-L)
AR13134		USE	3018527	EL16053		USE	NT7205Y (H-R B-R)
AR13135		USE	3049186	EL16060		USE	N7206 (H-R B-R)
AR13136		USE	3049186	EL16070		USE	N7205B (H-R B-L)
AR13139		USE	3049186	EL16072		USE	N7207A (H-R B-L)
AR13140		USE	3018527	EL16080		USE	N7208 (H-R B-R)
AR13141		USE	3018527	EL16090		USE	N7209 (H-R B-R)
AR13142		USE	3049186	EL16100		USE	N7210 (H-R B-R)
AR13150		USE	3049186	EL16100		USE	N7210E (H-L B-R)
AR13160		USE	3049186	EL16111		USE	N7211 (H-L B-L)
AR40220		USE	3049186	EL16112		USE	N7211B (H-L B-L)
AR45211		USE	3049186	EL16120		USE	N7212 (H-R B-R)
AR45603		USE	3018527	EL16160		USE	275789
AR51688		USE	3018527	EL16200		USE	NT7220 (H-R B-R)
AR7944		USE	3018527	EL16250		USE	N7225 (H-R B-R)
AR8053		USE	3049186	EL16280		USE	NT7228A (H-R B-R)
AR8161		USE	3049186	EL16312		USE	NT7231 (H-L B-L)
AR8307		USE	3049186	EL365007		USE	N7212FM
AR8311		USE	3018527	EL365131		USE	N7212FP
AR8312		USE	3018527	EL365132		USE	N7212FP
AR8371		USE	3049186	EL365151		USE	N7212FP
EL13020		USE	N7002A (H-R B-R)	EL365152		USE	N7212FP
EL13020		USE	N7002AJ (H-R B-L)	K022105	61	80B	AD-IP Purge Vlv. New Style
EL13020		USE	N7002F (H-L B-R)	KN12010		USE	N6000B (Air Ports-R)
EL13020		USE	NT7002 (H-L B-R)	KN12020		USE	N6000 (Air Ports-L)
EL13020		USE	NT7002A (H-R B-R)	KN12030		USE	N5217 (Air Ports-R)
EL13021		USE	NT7002AB (H-L B-L)	KN12031		USE	N5217 (Air Ports-R)
EL13022		USE	N7002Z (H-L B-R)	KN12040		USE	N5217BA (Air Ports-L)
EL13023		USE	NT7002AS (H-R B-L)	KN12041		USE	N5217BA (Air Ports-L)
EL13040		USE	NT7004B (H-R B-R)	KN12050		USE	N5120 (Air Ports-R)
EL13050		USE	N7005A (H-R B-R)	KN12050		USE	N5120H (Air Ports-L)
EL13050		USE	N7005P (H-L B-R)	KN12060		USE	N5700K (Air Ports-L)
EL13050		USE	NT7005AD (H-L B-R)	KN12061		USE	N5700K (Air Ports-L)
EL13051		USE	NT7005AF (H-R B-L)	KN12070		USE	N5706E (Air Ports-R)
EL13051		USE	NT7005M (H-R B-R)	KN12071		USE	N5706E (Air Ports-R)
EL13052		USE	N7005AD (H-L B-R)	KN12081		USE	N5708C (Air Ports-L)
EL13053		USE	NT7005AK (H-R B-L)	KN12091		USE	N5709B (Air Ports-R)
EL13060		USE	N7006 (H-R B-R)	KN12100		USE	N5904G (Air Ports-R)
EL13070		USE	N7005R (H-R B-L)	KN12101		USE	N5904G (Air Ports-R)
EL13080		USE	N7008 (H-R B-R)	KN12111		USE	N5904J (Air Ports-L)

# PRIOR AUTOMOTIVE PRODUCTS, LLC

## NUMERICAL LISTING AND INTERCHANGE

PART NO.	PAGE NO.	PICTURE REF.	DESCRIPTION OR INTERCHANGE NO. (H)-HEAD (B)-BLOCK (R)-RIGHT (L)-LEFT	PART NO.	PAGE NO.	PICTURE REF.	DESCRIPTION OR INTERCHANGE NO. (H)-HEAD (B)-BLOCK (R)-RIGHT (L)-LEFT
KN12120		USE	N5902E (Air Ports-R)	KN20010		USE	N14488AE
KN12131		USE	N5215 (Air Ports-R)	KN20020		USE	N14488AK
KN12140		USE	N5222 (Air Ports-L)	KN20021		USE	275176-N
KN12140		USE	N5222B (Air Out - R)	KN20025		USE	286706
KN12151		USE	N5235 (Air Ports-L)	KN20030		USE	N20928A
KN12151		USE	N5235C (Air Ports-R)	KN20031		USE	N20928A
KN12160		USE	N5224 (Air Ports-R)	KN20033		USE	N20928B
KN12160		USE	N5224A (Air Ports-L)	KN20035		USE	287238
KN12171		USE	N5909C (Air Ports-R)	KN20040		USE	229608
KN12180		USE	N5236 (Air Ports -R)	KN20041		USE	229617
KN12180		USE	N5236C (Air Ports-L)	KN20060		USE	276635
KN12190		USE	N5212 (Air Ports-L)	KN20061		USE	276635
KN12190		USE	N5212A (Air Ports-L)	KN20080		USE	N15791D
KN12200		USE	N5060 (Air Ports-R)	KN20090		USE	N15791F
KN12200		USE	N5060D (Air Ports-L)	KN20110		USE	N15791J
KN12210		USE	N5125 (Air Ports-L)	KN20540		USE	N30103BB
KN12220		USE	N5151 (Air Ports-L)	KN20541		USE	N30103BB
KN12220		USE	N5151B (Air Ports-R)	KN20542		USE	N30103BF
KN12230		USE	N5907 (Air Ports-L)	KN20550		USE	N30107BA
KN13020		USE	N7002A (H-R B-R)	KN20551		USE	N30107BA
KN13020		USE	N7002F (H-L B-R)	KN20552		USE	N30107BB
KN13021		USE	N7002AJ (H-R B-L)	KN20561		USE	276272
KN13021		USE	N7002H (H-L B-L)	KN20570		USE	N30107BB
KN13040		USE	N7004C (H-R B-R)	KN20611		USE	N4400B
KN13040A		USE	N7004H (H-R B-L)	KN20612		USE	N4400A
KN13050		USE	N7005A (H-R B-R)	KN20615		USE	N4400
KN13050		USE	N7005P (H-L B-R)	KN22040		USE	N20805B
KN13050		USE	NT7005AD (H-L B-R)	KN22050		USE	N20806A
KN13060		USE	N7006 (H-R B-R)	KN22060		USE	N20805B
KN13070		USE	N7005F (H-I B-L)	KN22070		USE	N20806A
KN13070		USE	N7005R (H-R B-L)	KN22090		USE	N20804A
KN13080		USE	N7008 (H-R B-R)	KN22100		USE	N20837
KN13080A		USE	N7008A (H-R B-R)	KN22110		USE	N20837
KN13090		USE	N7009 (H-R B-R)	KN22120		USE	N30083
KN13090		USE	N7009E (H-L B-R)	KN22130		USE	N30083
KN13100		USE	N7010 (H-R B-R)	KN22140		USE	N30099AB
KN13100		USE	N7010A (H-L B-R)	KN22150		USE	N30099AB
KN13110		USE	N7011 (H-L B-L)	KN22150		USE	N30099LA
KN13120		USE	N7012A (H-R B-R)	KN22501		USE	N30099AB
KN13140		USE	N7014B (H-R B-R)	KN22511		USE	N30099AB
KN13151		USE	N7015 (H-R B-R)	KN22521		USE	N30099AB
KN13160		USE	N7016 (H-L B-R)	KN22600		USE	N20837
KN13170		USE	N7017 (H-R B-R)	KN22610		USE	N20837
KN13200		USE	N7020 (H-R B-R)	KN22620		USE	N20837
KN13260		USE	N7026 (H-R B-R)	KN23000		USE	227788
KN13280		USE	NT7028C (H-R B-R)	KN23010		USE	227870
KN13300		USE	NT7030 (H-R B-R)	KN24000		USE	281923
KN13312		USE	NT7031B (H-L B-L)	KN24001		USE	281923
KN13330		USE	NT7033D (H-R B-R)	KN25060		USE	278614
KN14050		USE	NT7305 (H-R B-R)	KN25080		USE	287180
KN14051		USE	NT7305A (H-L B-R)	KN26000		USE	A104001
KN14111		USE	N7311 (H-L B-R)	KN26010		USE	N4305AA
KN16020		USE	N7202A (H-R B-R)	KN28010		USE	N20829C
KN16020		USE	N7202H (H-R B-L)	KN28010		USE	N20829C
KN16040		USE	N7204 (H-R B-R)	KN28030		USE	N20950
KN16051		USE	N7205 (H-R B-R)	KN28040		USE	N4350BA
KN16051		USE	N7205D (H-L B-R)	KN28050		USE	N4350AA
KN16051		USE	N7205P (H-L B-L)	KN28060		USE	N30096
KN16060		USE	N7206 (H-R B-R)	KN28061		USE	N30096L
KN16070		USE	N7205B (H-R B-L)	KN28065		USE	N30100AR
KN16072		USE	N7207A (H-R B-L)	KN28070		USE	N30100
KN16080		USE	N7208 (H-R B-R)	KN28071		USE	N30100AD
KN16090		USE	N7209 (H-R B-R)	KN28080		USE	N30096N
KN16100		USE	N7210 (H-R B-R)	KN28130		USE	N30106
KN16100		USE	N7210E (H-L B-R)	KN28131		USE	N30106F
KN16111		USE	N7211 (H-L B-L)	KN28132		USE	N30106D
KN16111		USE	N7211B (H-L B-L)	KN28140		USE	N30100AG
KN16120		USE	N7212 (H-R B-R)	KN28150		USE	N30100BA
KN16160		USE	N7216 (H-R B-R)	KN28160		USE	A86477
KN16200		USE	NT7220 (H-R B-R)	KN28500		USE	A78880-N
KN16250		USE	N7225 (H-R B-R)	KN28510		USE	A78889-N
KN16280		USE	NT7228A (H-R B-R)	KN28520		USE	A78887-N
KN16312		USE	NT7231 (H-L B-L)	KN28550		USE	N30110A
KN18500		USE	N20841	KN28551		USE	N30110AB
KN18510		USE	N30095	KN28600		USE	N4304AC
KN18511		USE	N30095	KN28601		USE	N4304AB
KN18530		USE	275200	KN30010		USE	A71890-N
KN20000		USE	229617	KN30100		USE	A37480
KN20001		USE	282058	KN30200		USE	A71891-N

# PRIOR AUTOMOTIVE PRODUCTS, LLC

## NUMERICAL LISTING AND INTERCHANGE

PART NO.	PAGE NO.	PICTURE REF.	DESCRIPTION OR INTERCHANGE NO. (H)-HEAD (B)-BLOCK (R)-RIGHT (L)-LEFT	PART NO.	PAGE NO.	PICTURE REF.	DESCRIPTION OR INTERCHANGE NO. (H)-HEAD (B)-BLOCK (R)-RIGHT (L)-LEFT
KN30300		USE	A71890-N	KNT13053		USE	NT7005AK (H-R B-L)
KN30400		USE	A99036	KNT13100		USE	NT7010F (H-R B-R)
KN31000		USE	N15759E	KNT13111		USE	N7011 (H-L B-L)
KN31010		USE	N15759E	KNT13120		USE	NT7012B (H-R B-R)
KN31020		USE	N15759E	KNT13151		USE	NT7015A (H-R B-R)
KN31040		USE	279716	KNT13170		USE	NT7017 (H-R B-R)
KN31050		USE	277215	KNT13190		USE	NT7019
KN31060		USE	277144	KNT13200		USE	NT7020 (H-R B-R)
KN31070		USE	N10044K	KNT13220		USE	NT7022E (H-R B-R)
KN31080		USE	N13069	KNT16020		USE	NT7202G (H-L B-L)
KN31090		USE	N13069	KNT16040		USE	NT7204 (H-R B-R)
KN31100		USE	N13069	KNT16051		USE	NT7205F (H-R B-R)
KN31110		USE	205105	KNT16051A		USE	NT7205V (H-R B-L)
KN32000		USE	205000	KNT16051A		USE	NT7205P (H-L B-L)
KN32003		USE	229860	KNT16053		USE	NT7205Y (H-R B-R)
KN32005		USE	229859	KNT85150		USE	NT7515 (Int.Mfl.-R)
KN32006		USE	229859	KNT85230		USE	NT7523 (Int.Mfl.-R)
KN32010		USE	229859	KNT85290		USE	NT7529 (Int. Mfl.-R)
KN32011		USE	229860	KNT86020		USE	NT7602A (Int. Mfl.-L)
KN32013		USE	229860	KNT86230		USE	NT7623 (Int. Mfl.-R)
KN32020		USE	229813	KNT86301		USE	NT7630 (Int. Mfl.-R)
KN32030		USE	225433	KO19983	48	9	BA921 Compressor
KN32040		USE	N20952AC	KO31987	48	9	BA921 Compressor
KN32041		USE	N20952AD	KO34655	48	9	BA921 Compressor
KN32042		USE	289714	KO55770	48	9	BA921 Compressor
KN32050		USE	278483	KO66833	48	9	BA921 Compressor
KN32055		USE	229813	KZ1087		no pic	Bendix Euro - Twin
KN32060		USE	278483	KZ108714		no pic	Bendix Euro - Twin
KN34000		USE	N20592	LK1554		no pic	Knorr-Bremse - Single
KN34030		USE	N30073	LK1900		no pic	Knorr-Bremse - Single
KN34040		USE	N205921H	LK3834		no pic	Knorr-Bremse - Single
KN34050		USE	N30073EA	LK3965		no pic	Knorr-Bremse - Single
KN34060		USE	N20949M	LK3966		no pic	Knorr-Bremse - Single
KN34070		USE	N30073DE	LK4962		no pic	Bendix Euro - Twin
KN35070		USE	N2837A	N13069C		USE	N13069
KN40000		USE	N3598	N13440AA		USE	229608
KN40030		USE	N20909	N13440H		USE	229617
KN40040		USE	N20909A	N14641		USE	N15759E
KN7000		USE	N6400 (Air Ports-R)	N15352		USE	N14188A
KN7000		USE	N6400E (Air Ports-L)	N15365A		USE	N13069
KN7010		USE	N5601C (Air Ports-R)	N15709B		USE	N14188D
KN7020		USE	N5601E (Air Ports-L)	N15709C		USE	N14188D
KN7030		USE	N6300 (Air Ports-R)	N15760		USE	276635
KN7030		USE	N6300E (Air Ports-L)	N157606		USE	276635
KN7040		USE	N5303D (Air Ports-R)	N15817A		USE	279716
KN7041		USE	N5310C (Air Ports-L)	N202117B-C		USE	N20841
KN7050		USE	N5303E (Air Ports-L)	N20669B		USE	225433
KN7060		USE	N5502 (Air Ports-R)	N20804		USE	N20804A
KN7070		USE	N5502A (Air Ports-R)	N20804C		USE	N20804A
KN7080		USE	N5502H (Air Ports-L)	N20805		USE	N20805B
KN7090		USE	N6402 (Air Ports-L)	N20806		USE	N20806A
KN7100		USE	N5026 (Air Ports-R)	N20823		USE	N20804A
KN7100		USE	N5026A (Air Ports-L)	N20856		USE	275200
KN7110		USE	N5026A (Air Ports-L)	N20928G		USE	N20928A
KN7120		USE	N5026W (Air Ports-L)	N20949CA		USE	N20949AA
KN7140		USE	N5107 (Air Ports-L)	N20952AE		USE	289714
KN7140		USE	N5107B (Air Ports-R)	N20954N		USE	278597
KN7150		USE	N5107A (Air Ports-L)	N20959DA		USE	278483
KN7160		USE	N5107W (Air Ports-R)	N20959DB		USE	278483
KN7170		USE	N5309 (Air Ports-R)	N20959DC		USE	N20959CB
KN7180		USE	N5309A (Air Ports-L)	N20959EA-N		USE	229860
KN85020		USE	N7502 (Int. Mfl. -R)	N20959EB		USE	229859
KN85020		USE	N7502B (Int. Mfl. -R)	N20959EC		USE	N20959EB
KN85020		USE	NT7502J (Int. Mfl.-R)	N20959HA		USE	229860
KN85021		USE	N7602B (Int. Mfl.-L)	N20959HB		USE	229859
KN85021		USE	N7602D (Int. Mfl.-L)	N20959MA		USE	229860
KN85022		USE	N7502C (Int. Mfl.-R)	N20959MB		USE	229859
KN86020		USE	N7602 (Int. Mfl.-R)	N20959NA		USE	229860
KN86020		USE	N7602A (Int. Mfl.-R)	N20959NB		USE	229859
KN86022		USE	N7602H (Int. Mfl.-R)	N20959NC		USE	278483
KNT13020		USE	NT7002 (H-L B-R)	N20959ND		USE	278483
KNT13020		USE	NT7002AA (H-R B-R)	N20961		USE	286706
KNT13020		USE	N7002Z (H-L B-R)	N20964		USE	287238
KNT13021		USE	NT7002AB (H-L B-L)	N2350L		USE	N2350
KNT13023		USE	NT7002AS (H-R B-L)	N30028H-J-K		USE	N30099AB
KNT13040		USE	NT7004B (H-R B-R)	N30033		USE	N205921H
KNT13050		USE	NT7005AD (H-L B-R)	N30072M-AB		USE	N30099AB
KNT13050		USE	NT7005M (H-R B-R)	N30073FF		USE	N30073
KNT13051		USE	NT7005AF (H-R B-L)	N30073GA		USE	N30073DE

# PRIOR AUTOMOTIVE PRODUCTS, LLC

## NUMERICAL LISTING AND INTERCHANGE

PART NO.	PAGE NO.	PICTURE REF.	DESCRIPTION OR INTERCHANGE NO. (H)-HEAD (B)-BLOCK (R)-RIGHT (L)-LEFT	PART NO.	PAGE NO.	PICTURE REF.	DESCRIPTION OR INTERCHANGE NO. (H)-HEAD (B)-BLOCK (R)-RIGHT (L)-LEFT
N30090		USE	N30095	N4304AC-N	76	149	MID. FFV
N30095		USE	275200	N4304AD		USE	N4304AB
N30096	75	142	KN28060 -(2 3/8" Del. Ports)	N4304AE		USE	N4304AC
N30096E		USE	N30096	N4304B		USE	N4304AC
N30096F		USE	N30096	N4304C		USE	N4304AB
N30096J		USE	N30096L	N4305AA	77	155	RT4 Sprng Brake - NEW
N30096L	75	142	KN28061 (2 - 1/2" Del. Ports)	N4350D-BD		USE	N4350BA
N30096N	75	142	KN28080 -(4 3/8" Del. Ports)	N4350E-AB		USE	N4350M
N30099AC		USE	N30099AB	N4400	71	118	MV Dash - R&R Exch. Only
N30100HJ		USE	N30100AD	N4400A	71	118	MV Dash - R&R Exch. Only
N30103A		USE	N30103BB	N4400B	71	118	MV Dash - R&R Exch. Only
N30103BA		USE	N30103BB	N50028		USE	NT7305A
N30103BC		USE	N30103BB	N5025-A		USE	N5026A
N30103BD		USE	N30103BF	N5025-AW		USE	N5026W
N30103BE		USE	N30103BF	N5025-D		USE	N5026W
N30103BH		USE	N30103BB	N5026		no pic	Mid 7 1/4 Air Prt-R
N30107BC		USE	N30107BA	N5026-A		no pic	Mid 7 1/4 Port-L
N30107BD		USE	N30107BA	N5026-AW		USE	N5026W
N30107BE		USE	N30107BA	N5026CW		no pic	Mid 7 1/4 Ports-R
N3598A-B		USE	N3598	N5026-D		USE	N5026
N3857A		USE	N3598	N5026-E		USE	N5026
N3973B		USE	N3990	N5026F		no pic	Mid Type 7 1/4
N3974A-B		USE	N20804A	N5026G		no pic	Mid 7 1/4 Ports-R
N3977A		USE	N20806A	N5026H		no pic	Mid Type 7 1/4
N3977B		USE	N20805B	N5026W		no pic	Mid 7 1/4 Ports-L
N3978A		USE	N20806A	N5060	50	19	Mid 12 Ports-R
N3991		USE	N20804A	N5060D	50	19	Mid 12 Ports-L
N3991AB		USE	N20804A	N5084-W		USE	N6300
N3994D		USE	N20805B	N5085-AW		USE	N6300E
N4170A		USE	N4170F	N5085-DW		USE	N6300E
N4170F	64	83	Mid Press Conv	N5085-EW		USE	N6300E
N4170G	64	83	Mid Press Conv	N5085-FW		USE	N6300
N4170J		USE	N4170L	N5085-GW		USE	N6300E
N4170L	64	83	Mid Press Conv	N5085-HW		USE	N6300
N4170M	64	83	Mid Press Conv	N5085-W		USE	N6300
N4170N	64	83	Mid Press Conv	N5098-A		USE	N6400
N4170R	64	83	Mid Press Conv	N5098-AW		USE	N6300E
N4170T		USE	N4170L	N5098-CW		USE	N6300E
N4171		USE	A71890	N5098-DW		USE	N6300E
N4171F		USE	A71890	N5098-EW		USE	N6300E
N4173		USE	N30083	N5098-W		USE	N6300
N4174		USE	N4174B	N5107		no pic	Mid 7 1/4 Ports-L
N4174B	64	83	Mid Press Conv	N5107A		no pic	Mid 7 1/4 Ports-L
N4174D		USE	N4174E	N5107B		no pic	Mid 7 1/4 Ports-R
N4174E	64	83	Mid Press Conv	N5107-C		USE	N5107B
N4174F	64	83	Mid Press Conv	N5107W		no pic	Mid 7 1/4 Ports-R
N4190		USE	N4190A	N5108-A		USE	N5107A
N4190A	64	83	Mid Press Conv	N5108-B		USE	N5107W
N4190C	64	83	Mid Press Conv	N5108-C		USE	N5107W
N4190E	64	83	Mid Press Conv	N5108-W		USE	N5107W
N4190H	64	83	Mid Press Conv	N5113		USE	N6300
N4194	64	83	Mid Press Conv	N5120	50	19	Mid 12 (Ports-R)
N4194B	64	83	Mid Press Conv	N5120-A		USE	N5120
N4194C		USE	N4194B	N5120H	50	19	Mid 12 (Ports-L)
N4194D	64	83	Mid Press Conv	N5120-K M		USE	N5120
N4194E	64	83	Mid Press Conv	N5120-N		USE	N5120H
N4270	64	83	Mid Press Conv	N5120-P		USE	N5120
N4270C	64	83	Mid Press Conv	N5120-R		USE	N5120
N4274	64	83	Mid Press Conv	N5120S	50	19	Mid 12 (Ports-L)
N4274A	64	83	Mid Press Conv	N5120-T		USE	N5120
N4274B	64	83	Mid Press Conv	N5120-V		USE	N5120
N4274D	64	83	Mid Press Conv	N5120-W		USE	N5120H
N4274E	64	83	Mid Press Conv	N5122		USE	N5212
N4274F	64	83	Mid Press Conv	N5122-A		USE	N5212A
N4286	64	83	Mid Press Conv	N5122-B		USE	N5212A
N4290A	64	83	Mid Press Conv	N5122-C		USE	N5212A
N4290B	64	83	Mid Press Conv	N5125	50	19	Mid 12 (Ports-L)
N4290C	64	83	Mid Press Conv	N5125-A		USE	N5125
N4290D	64	83	Mid Press Conv	N5125-B		USE	N5125
N4290E	64	83	Mid Press Conv	N5126		USE	N5125
N4294	64	83	Mid Press Conv	N5126-A		USE	N5125
N4294B	64	83	Mid Press Conv	N5126-B		USE	N5125
N4301AA		USE	A37480	N5137-A		USE	N5060D
N4301AA		USE	A71890	N5137-B		USE	N5060
N4301BA		USE	A71891	N5137-C		USE	N5060
N4301CB		USE	A99036	N5137-D		USE	N5060
N4304		USE	N4304AC	N5137-G		USE	N5060
N4304A		USE	N4304AB	N5150-A		USE	N5151
N4304AB-N	76	149	MID. FFV	N5150-C		USE	N5151

# PRIOR AUTOMOTIVE PRODUCTS, LLC

## NUMERICAL LISTING AND INTERCHANGE

PART NO.	PAGE NO.	PICTURE REF.	DESCRIPTION OR INTERCHANGE NO. (H)-HEAD (B)-BLOCK (R)-RIGHT (L)-LEFT	PART NO.	PAGE NO.	PICTURE REF.	DESCRIPTION OR INTERCHANGE NO. (H)-HEAD (B)-BLOCK (R)-RIGHT (L)-LEFT
N5150-D		USE	N5151	N5303-G		USE	N5303E
N5150-E		USE	N5151	N5303-H		USE	N5303D
N5150-F		USE	N5151	N5303-J		USE	N5303E
N5150-G		USE	N5151	N5303-M		USE	N5303D
N5151	50	19	Mid 12 (Ports-L)	N5303-N		USE	N5303E
N5151-A		USE	N5151	N5303-S		USE	N5303D
N5151B	50	19	Mid 12 (Ports-R)	N5303-V		USE	N5303E
N5151-C		USE	N5151	N5303-W		USE	N5303D
N5151-D		USE	N5151	N5303-X		USE	N5303D
N5151-E		USE	N5151	N5308		USE	N5303D
N5151-F		USE	N5151	N5308-A		USE	N5303D
N5151-G		USE	N5151	N5308-B		USE	N5303E
N5160		no pic	Mid Type 7 1/4	N5308-C		USE	N5303D
N5160C		no pic	Mid Type 7 1/4	N5308-D		USE	N5303D
N5160-D		USE	N5160C	N5309		no pic	Mid 7 1/4 Ports-R
N5212	50	19	Mid 12 (Ports-L)	N5309A		no pic	Mid 7 1/4 Ports-L
N5212A	50	19	Mid 12 (Ports-R)	N5310		no pic	Mid 7 1/4 Ports-R
N5212-B		USE	N5212A	N5310A		no pic	Mid 7 1/4 Ports-L
N5212-C		USE	N5212A	N5407-B		USE	N5601C
N5212-D		USE	N5212A	N5407-E		USE	N5601C
N5212-E		USE	N5212	N5408-A		USE	N5601C
N5212-F		USE	N5212	N5408-B		USE	N5601C
N5212-G		USE	N5212A	N5408-C		USE	N5601C
N5212-H		USE	N5212A	N5408-D		USE	N5601C
N5212-J		USE	N5212A	N5409-A		USE	N5601E
N5212-K		USE	N5212A	N5409-B		USE	N5601E
N5212-L		USE	N5212	N5502		no pic	Mid 7 1/4 Ports-R
N5214-A		USE	N5215	N5502A		no pic	Mid 7 1/4 Ports-R
N5215	50	19	Mid 12 (Ports-R)	N5502-B		USE	N5502A
N5215-A		USE	N5215	N5502-C		USE	N5502
N5215-B		USE	N5215	N5502-F		USE	N5502A
N5215-BA		USE	N5215	N5502-G		USE	N5502
N5215-C		USE	N5215	N5502H		no pic	Mid 7 1/4 Ports-L
N5215-D		USE	N5215	N5502-J		USE	N5502
N5215-E		USE	N5215	N5504		USE	N5502
N5215-G		USE	N5215	N5504-A		USE	N5502H
N5215-H		USE	N5215	N5504-B		USE	N5502A
N5215-J		USE	N5215	N5601 -V		USE	N5601C
N5217	50	19	Mid 12 (Ports-R)	N5601-B		USE	N5601C
N5217-A		USE	N5217	N5601C		no pic	Mid 7 1/4 Ports-R
N5217-B		USE	N5217	N5601-D		USE	N5601C
N5217BA	50	19	Mid 12 (Ports-L)	N5601E		no pic	Mid 7 1/4 Ports-L
N5217-BB		USE	N5217	N5601-F		USE	N5601C
N5217-BD		USE	N5217BA	N5601-G		USE	N5601C
N5217-BE		USE	N5217BA	N5601-J		USE	N5601E
N5217-BF		USE	N5217BA	N5601-K		USE	N5601C
N5217-BG		USE	N5217BA	N5601-L		USE	N5601E
N5217-BH		USE	N5217	N5601-M		USE	N5601C
N5217-C		USE	N5217BA	N5601-P		USE	N5601C
N5217-D		USE	N5217	N5601-R		USE	N5601E
N5217-E		USE	N5217BA	N5601-S		USE	N5601E
N5217-F		USE	N5217BA	N5601-W		USE	N5601E
N5217-G		USE	N5217BA	N5603		USE	N5601C
N5217-H		USE	N5217BA	N5603-A		USE	N5601E
N5217-K		USE	N5217	N5603-C		USE	N5601E
N5217-L		USE	N5217	N5603-D		USE	N5601C
N5217-M		USE	N5217	N5700-B		USE	N5217
N5217-N		USE	N5217SA	N5700-C		USE	N5217BA
N5217-P		USE	N5217	N5700-D		USE	N5217
N5217-R		USE	N5217BA	N5700-E		USE	N5217BA
N5222	50	19	Mid 12 (Ports-L)	N5700-F		USE	N5217
N5222-A		USE	N5222	N5700-G		USE	N5217BA
N5222B	50	19	Mid 12 (Ports-L)	N5700-H		USE	N5217
N5222-C		USE	N5222	N5700-J		USE	N5217BA
N5222-D		USE	N5222	N5700K	50	19	Mid 12 (Ports-L)
N5224	50	19	Mid 12 (Ports-R)	N5700-L		USE	N5700K
N5224A	50	19	Mid 12 (Ports-L)	N5700-N		USE	N5217BA
N5235	50	19	Mid 12 (Ports-L)	N5700-P		USE	N5217
N5235-B		USE	N5235	N5702-B		USE	N5217
N5235-BA		USE	N5235C	N5706-A		USE	N5217
N5235C	50	19	Mid 12 (Ports-R)	N5706-BA		USE	N5217
N5235-D		USE	N5235C	N5706-BB		USE	N5700K
N5236	50	19	Mid 12 (Ports-R)	N5706-BC		USE	N5217BA
N5236C	50	19	Mid 12 (Ports-L)	N5706-BD		USE	N5706E
N5303-B		USE	N5303D	N5706E	50	19	Mid 12 (Ports-R)
N5303-C		USE	N5303E	N5706-F		USE	N5217
N5303D		no pic	Mid 7 1/4 Ports-R	N5706-G		USE	N5217BA
N5303E		no pic	Mid 7 1/4 Ports-L	N5706-H		USE	N5706E
N5303-F		USE	N5303D	N5706-J		USE	N5217

# PRIOR AUTOMOTIVE PRODUCTS, LLC

## NUMERICAL LISTING AND INTERCHANGE

PART NO.	PAGE NO.	PICTURE REF.	DESCRIPTION OR INTERCHANGE NO. (H)-HEAD (B)-BLOCK (R)-RIGHT (L)-LEFT	PART NO.	PAGE NO.	PICTURE REF.	DESCRIPTION OR INTERCHANGE NO. (H)-HEAD (B)-BLOCK (R)-RIGHT (L)-LEFT
N5706-K		USE	N5700K	N6000B	50	19	Mid 12 (Ports-R)
N5706-L		USE	N5706E	N6000-BA		USE	N6000B
N5706-M		USE	N5700K	N6000-BB		USE	N6000
N5706-P		USE	N5217	N6000-BC		USE	N6000B
N5706-R		USE	N5706E	N6000-BD		USE	N6000B
N5706-S		USE	N5217	N6000-BE		USE	N6000B
N5706-T		USE	N5706E	N6000-E		USE	N6000B
N5706-V		USE	N5217	N6000-F		USE	N6000
N5706-W		USE	N5217	N6000-G		USE	N6000B
N5706-X		USE	N5700K	N6000-H		USE	N6000B
N5706-Y		USE	N5706E	N6000-K		USE	N6000B
N5708-A		USE	N5708C	N6000-L		USE	N6000B
N5708-B		USE	N5700K	N6300		no pic	Mid 7 1/4 Ports-R
N5708-BA		USE	N5708C	N6300-A		USE	N6300
N5708C	50	19	Mid 12 (Ports-L)	N6300-AB		USE	N6300E
N5708-F		USE	N5708C	N6300-AC		USE	N6300
N5708-G		USE	N5708C	N6300-C		USE	N6300
N5709-6		USE	N5709B	N6300-D		USE	N6300
N5709B	50	19	Mid 12 (Ports-R)	N6300E		no pic	Mid 7 1/4 Ports-L
N5709C	50	19	Mid 12 (Ports-R)	N6300-F		USE	N6300E
N5902-B		USE	N5902E	N6300-G		USE	N6300
N5902-C		USE	N5902E	N6300-H		USE	N6300E
N5902-D		USE	N5902E	N6300-J		USE	N6300
N5902E	50	19	Mid 12 (Ports-R)	N6300-K		USE	N6300E
N5903-B		USE	N5217	N6300-M		USE	N6300
N5903-BA		USE	N5217	N6300-M		USE	N6300
N5903-BB		USE	N5217	N6300-N		USE	N6300
N5903-BC		USE	N5217BA	N6300-P		USE	N6300
N5903-BD		USE	N5217	N6300-R		USE	N6300E
N5903-BE		USE	N5217	N6300-S		USE	N6300
N5903-BF		USE	N5217	N6300-T		USE	N6300E
N5903-BG		USE	N5217	N6300-W		USE	N6300E
N5903-BH		USE	N5217BA	N6300-X		USE	N6300E
N5903-BJ		USE	N5217	N6300-Y		USE	N6300
N5903-BK		USE	N5217	N6300-Y		USE	N6300E
N5903-BL		USE	N5217	N6300-Z		USE	N6300
N5903-BM		USE	N5217	N6304A		no pic	Mid 7 1/4 Ports-R
N5903-C		USE	N5217	N6400		no pic	Mid 7 1/4 Ports-R
N5903-D		USE	N5217	N6400-A		USE	N6400
N5903-F		USE	N5217	N6400-D		USE	N6400
N5903-G		USE	N5217	N6400E		no pic	Mid 7 1/4 Ports-L
N5903-H		USE	N5217	N6400-F		USE	N6400
N5903-J		USE	N5217	N6400-G		USE	N6400
N5903-L		USE	N5217	N6400-J		USE	N6400E
N5903-M		USE	N5217BA	N6400-K		USE	N6400E
N5903-P		USE	N5217	N6400-L		USE	N6400E
N5903-R		USE	N5217	N6400-M		USE	N6400E
N5903-S		USE	N5217	N6400-N		USE	N6400
N5903-T		USE	N5217	N6402		no pic	Mid 7 1/4 Ports-L
N5903-V		USE	N5217	N6403		USE	N6400
N5903-W		USE	N5217	N6403		USE	N6400E
N5903-Y		USE	N5217SA	N6700-A	50	USE	N5120H
N5903-Z		USE	N5217	N7002A		20	EL 1300 (H-R B-R)
N5904-B		USE	N5904G	N7002AA		USE	N7002A
N5904-BA		USE	N5904G	N7002-AC		USE	N7002A
N5904-BB		USE	N5904J	N7002AD		USE	N7002AJ
N5904-BC		USE	N5904G	N7002AE		USE	N7002A
N5904-BD		USE	N5904G	N7002AF		USE	N7002A
N5904-BE		USE	N5904G	N7002AG		USE	N7002A
N5904-BF		USE	N5904G	N7002AH		USE	N7002A
N5904-C		USE	N5904G	N7002AJ	50	20	EL 1300 (H-R B-L)
N5904-D		USE	N5904G	N7002AL		USE	N7002A
N5904G	50	19	Mid 12 (Ports-R)	N7002-C		USE	N7002A
N5904-H		USE	N5904G	N7002F	50	20	EL 1300 (H-L B-R)
N5904J	50	19	Mid 12 (Ports-L)	N7002-G		USE	N7002A
N5904-K		USE	N5904G	N7002H	50	20	EL 1300 (H-L B-L)
N5904-L		USE	N5904J	N7002-K		USE	N7002A
N5904-M		USE	N5904J	N7002-L		USE	N7002H
N5904-N		USE	N5904G	N7002-M		USE	N7002F
N5907	50	19	Mid 12 (Ports-L)	N7002-M		USE	N7002H T
N5908		USE	N5217BA	N7002-N		USE	N7002F
N5909		USE	N5909C	N7002-P		USE	N7002A
N5909-A		USE	N5904G	N7002-R		USE	N7002A
N5909-BA		USE	N5909C	N7002-S		USE	N7002F
N5909C	50	19	Mid 12 (Ports-R)	N7002-T		USE	N7002F
N5909-D		USE	N5909C	N7002-V		USE	N7002A
N5909-H		USE	N5909C	N7002-W		USE	N7002F
N5909-J		USE	N5904G	N7002-X		USE	N7002H
N6000	50	19	Mid 12 (Ports-L)	N7002Z	50	20	EL 1300 (H-L B-R)

# PRIOR AUTOMOTIVE PRODUCTS, LLC

## NUMERICAL LISTING AND INTERCHANGE

PART NO.	PAGE NO.	PICTURE REF.	DESCRIPTION OR INTERCHANGE NO. (H)-HEAD (B)-BLOCK (R)-RIGHT (L)-LEFT	PART NO.	PAGE NO.	PICTURE REF.	DESCRIPTION OR INTERCHANGE NO. (H)-HEAD (B)-BLOCK (R)-RIGHT (L)-LEFT
N7004		USE	N7004C	N7205J		USE	N7205J
N7004C	50	20	EL 1300 (H-R B-R)	N7205L		USE	N7205B
N7004-D-F		USE	N7004C	N7205M		USE	N7205
N7004F		USE	NT7004B	N7205N		USE	N7205N
N7004H	50	20	EL 1300 (H-R B-L)	N7205P	50	20	EL 1600 (H-L B-L)
N7005		USE	N7005A	N7206	50	20	EL 1600 (H-R B-R)
N7005A	50	20	EL 1300 (H-R B-R)	N7207A	50	20	EL 1600 (H-R B-L)
N7005AC		USE	N7005A	N7208	50	20	EL 1600 (H-R B-R)
N7005AD	50	20	EL 1300 (H-L B-R)	N7209	50	20	EL 1600 (H-R B-R)
N7005AG		USE	N7005A	N7210	50	20	EL 1600 (H-R B-R)
N7005-B		USE	N7005A	N7210-A		USE	N7210
N7005D		USE	N7005A	N7210-C		USE	N7210
N7005F	50	20	EL 1300 (H-R B-L)	N7210-D		USE	N7210
N7005H		USE	N7005A	N7210E	50	20	EL 1600 (H-L B-R)
N7005-J		USE	N7005A	N7211	50	20	EL 1600 (H-L B-L)
N7005K	50	20	EL 1300 (H-L B-R)	N7211A		USE	N7211
N7005L		USE	N7005P	N7211B		USE	N7211
N7005-L		USE	N7005K	N7211C		USE	N7211
N7005-M	50	20	EL 1300 (H-R B-L)	N7211E		USE	N7211
N7005P	50	20	EL 1300 (H-L B-R)	N7212	50	20	EL 1600 (H-R B-R)
N7005R	50	20	EL 1300 (H-R B-L)	N7212-A		USE	N7212
N7005-V		USE	N7005A	N7212AR		no pic	EL365
N7005W		USE	N7005A	N7212FL		USE	10R9393
N7006	50	20	EL 1300 (H-R B-R)	N7212FP		USE	10R9393
N7006-B		USE	N7006	N7213	50	20	Mid EL 1600
N7006-C		USE	N7006	N7216	50	20	EL 1600 (H-R B-R)
N7008	50	20	EL 1300 (H-R B-R)	N7225	50	20	EL 1600 (H-R B-R)
N7008A	50	20	EL 1300 (H-L B-L)	N7311	50	21	EL 3200 (H-L B-R)
N7009	50	20	EL 1300 (H-R B-R)	N7311-A		USE	N7311
N7009-C		USE	N7009	N7311AA		USE	N7311
N7009-D		USE	N7009	N7311AB		USE	N7311
N7009E	50	20	EL 1300 (H-L B-R)	N7502	50	17	EL 850 (Int. Mfl.-R)
N7009-F		USE	N7009E	N7502A	50	17	EL 850 (Int. Mfl.-L)
N7009-H		USE	N7016	N7502C	50	17	EL 850 (Int. Mfl.-R)
N7010	50	20	EL 1300 (H-R B-R)	N7602	50	17	EL 850 (Int. Mfl.-R)
N7010A	50	20	EL 1300 (H-L B-R)	N7602B	50	17	EL 850 (Int. Mfl.-L)
N7010-B		USE	N7010	N7602C		USE	N7602
N7010-C		USE	N7010	N7602D		USE	N7602B
N7010-D		USE	N7010	N7602H		USE	N7602
N7010-E		USE	N7010A	N7602J		USE	N7602
N7010-F		USE	N7010A	N7602K		USE	N7602B
N7010G		USE	N7010	NT5506		no pic	Mid 7 1/4 Ports-L
N7010J		USE	N7010	NT7002	50	20	EL 1300 (H-L B-R)
N7011	50	20	EL 1300 (H-L B-L)	NT7002A	50	20	EL 1300 (H-R B-R)
N7011-A		USE	N7011	NT7002AA	50	20	EL 1300 (H-R B-R)
N7011B		USE	N7011	NT7002AB	50	20	EL 1300 (H-L B-L)
N7011C		USE	N7011	NT7002AH		USE	NT7002AA
N7011D		USE	N7011	NT7002AM		USE	NT7002AA
N7011E		USE	N7011	NT7002AS	50	20	EL 1300 (H-R B-L)
N7011F		USE	N7011	NT7002B	50	20	EL 1300
N7011H		USE	N7011	NT7004B	50	20	EL 1300 (H-R B-R)
N7012A	50	20	EL 1300 (H-R B-R)	NT7004L		USE	NT7004B
N7012-B		USE	N7012A	NT7005AD	50	20	EL 1300 (H-L B-R)
N7014	50	20	EL 1300	NT7005AF	50	20	EL 1300 (H-R B-L)
N7014A	50	20	EL 1300	NT7005AK	50	20	EL 1300 (H-R B-L)
N7014B	50	20	EL 1300 (H-R B-R)	NT7005M	50	20	EL 1300 (H-R B-R)
N7015	50	20	EL 1300 (H-R B-R)	NT7010F	50	20	EL 1300 (H-R B-R)
N7016	50	20	EL 1300 (H-L B-R)	NT7010H		USE	NT7010F
N7017	50	20	EL 1300 (H-R B-R)	NT7010K		USE	NT7010F
N7020	50	20	EL 1300 (H-R B-R)	NT7011	50	20	EL 1300 (H-L B-L)
N7026	50	20	EL 1300 (H-R B-R)	NT7012B	50	20	EL 1300 (H-R B-R)
N7111	50	20	EL 1300	NT7015A	50	20	EL 1300 (H-R B-R)
N7202		USE	N7202A	NT7017	50	20	EL 1300 (H-R B-R)
N7202A	50	20	EL 1600 (H-R B-R)	NT7019	50	20	EL 1300 (H-R B-R)
N7202C		USE	N7202A	NT7020	50	20	EL 1300 (H-R B-R)
N7202H	50	20	EL 1600 H-R B-L)	NT7022	50	20	EL 1300 (H-R B-R)
N7204	50	20	EL 1600 (H-R B-R)	NT7022E	50	20	EL 1300 (H-R B-R)
N7204-A		USE	N7204	NT7022G	50	20	EL 1300 (H-L B-R)
N7204-B		USE	N7204	NT7028C	50	20	EL 1300 (H-R B-R)
N7204H	50	20	Mid. EL 1600	NT7030	50	20	EL 1300 (H-R B-R)
N7205	50	20	EL 1600 (H-R B-R)	NT7030A		USE	NT7030
N7205-A		USE	N7205B	NT7031B	50	20	EL 1300 (H-L B-L)
N7205B	50	20	EL 1600 (H-R B-L)	NT7033D	50	20	EL 1300 (H-R B-R)
N7205-C		USE	N7205D	NT7202G	50	20	EL1600 (H-L B-L)
N7205D	50	20	EL 1600 (H-L B-R)	NT7204	50	20	EL 1600 (H-R B-R)
N7205-E		USE	N7205	NT7204B		USE	NT7204
N7205-F		USE	N7205	NT7204D		USE	NT7204
N7205-G		USE	N7205D	NT7204E		USE	NT7204
N7205-H		USE	N7205	NT7204F		USE	NT7204

# PRIOR AUTOMOTIVE PRODUCTS, LLC

## NUMERICAL LISTING AND INTERCHANGE

PART NO.	PAGE NO.	PICTURE REF.	DESCRIPTION OR INTERCHANGE NO. (H)-HEAD (B)-BLOCK (R)-RIGHT (L)-LEFT	PART NO.	PAGE NO.	PICTURE REF.	DESCRIPTION OR INTERCHANGE NO. (H)-HEAD (B)-BLOCK (R)-RIGHT (L)-LEFT
NT7205F	50	20	EL 1600 (H-R B-R)	065240		USE	109604
NT7205P	50	20	EL 1600 (H-L B-L)	065260		USE	107813
NT7205V	50	20	EL 1600 (H-R B-L)	065261		USE	107836
NT7205Y	50	20	EL 1600 (H-R B-R)	065262		USE	107869
NT7210E		USE	N7210E	065264		USE	107866
NT7210F		USE	N7210	065265		USE	107919
NT7210H		USE	N7210	065266		USE	109603
NT7220	50	20	EL 1600 (H-R B-R)	065273		USE	107981
NT7228A	50	20	EL 1600 H-R B-R)	065278		USE	108066
NT7228C		USE	NT7228A	065287		USE	108096
NT7231	50	20	EL 1600 (H-L B-L)	065288		USE	108110
NT7305	50	21	EL 3200 (H-R B-R)	065299		USE	108260
NT7305A	50	21	EL3200 (H-L B-R)	065300		USE	108261
NT7502J	50	17	EL 850 (Int. Mfl.-R)	065302		USE	107514
NT7515	50	17	EL 850 (Int. Mfl.-R)	065313-N	68	102	E12 - R&R - Exch. Only
NT7523	50	17	EL 850 (Int. Mfl.-R)	065314	68	103	E-14 - R&R - Exch. Only
NT7529	50	17	EL 850 (Int. Mfl.-R)	065317	68	103	E-14 - R&R - Exch. Only
NT7602A	50	17	EL 850 (Int. Mfl.-L)	065334		USE	108557
NT7623	50	17	EL 850 (Int. Mfl.-R)	065374		USE	108779
NT7630	50	17	EL 850 (Int. Mfl.-R)	065375		USE	108790
WAB413001	63	82A	Wabco 1200 12V Air Dryer - REF #95520	065376		USE	108804
WAB421009P	63	82B	Wabco 1200P 12V Air Dryer REF #95530	065382		USE	108854
WM763		USE	275175	065387		USE	108866
WM764		USE	286706	065388		USE	108869
WM772		USE	281481	065395	68	103	E-14 - R&R - Exch. Only
WM778-N	88	247	Press Prot Vlv	065408		USE	108935
1000		USE	A1000	065409		USE	108937
1500		USE	275200	065424		USE	108990
1600		USE	205000	065426		USE	109142
1602		USE	205000	065437-N	81	191	SR-5 S.B. VALVE
12020		USE	205105	065439-N	81	191	SR-5 S.B. VALVE
12021		USE	284143	065455		USE	104102
13241		USE	228750	065457		USE	109088
13255		USE	228477	065461		USE	109111
065021		USE	103211	065465		USE	109139
065038		USE	103212	065466		USE	109142
065039		USE	65060	065467		USE	109147
065046		USE	104039	065475		USE	109251
065047		USE	104039	065481		USE	109219
065049		USE	104041	065490		USE	107919
065050		USE	104042	065491		USE	109287
065054		USE	104102	065521		USE	109382
065055		USE	104103	065537		USE	109425
065060	75	140	HR-1 - R&R - Exch. Only	065538		USE	109426
065061		USE	65075	065542		USE	109451
065083		USE	104583	65601		USE	109552
065084		USE	104584	065606		USE	109603
065104-N	73	127	R12	065607		USE	109604
065124		USE	106439	065612	61	78	AD-IP Dryer - NEW
065125-N	73	128	R12	065638		USE	109647
065145-N	83	208	BPR1	065641		USE	109653
065146-N	83	208	BPR1	065642		USE	109659
065149		USE	106978	065643	72	122	Park Cntrl PP-DC-NEW
065150		USE	106985	065661	72	122	Park Cntrl PP-DC-NEW
065155		USE	107221	065664		USE	109809
065156-N	71	120	MV3 - NEW	065671		USE	107623
065157-N	71	120	MV3 - NEW	065672		USE	107622
065159	71	120	MV3 - NEW	065683		USE	109863
065160	71	120	MV3 - NEW	065684		USE	109139
065161	71	120	MV3 - NEW	065690	72	122	Park Cntrl PP-DC-NEW
065186	71	120	MV3 - NEW	065691	60	75	AD-SP - NEW
065187-N	71	120	MV3 - NEW	065713		USE	131075
065192	71	120	MV3 - NEW	065714		USE	131076
065197		USE	107506	10005-N	77	156	CARTRIDGE
065198		USE	107507	101090		USE	286542
065199		USE	107508	101100-N	68	100	E-10 DUAL BRAKE
065200		USE	107509	101112-N	81	189	SR-4 Trailer Spr
065201		USE	107510	101121		USE	101112
065202		USE	107511	101130		USE	287564
065203		USE	107512	101139		USE	101158
065204		USE	107513	101142		USE	289158
065205		USE	107514	101143		USE	276911
065206-N	73	129	R-12	101144		USE	289421
065207		USE	107526	101145		USE	289340
065208	71	120	MV3 - NEW	101151		USE	289925
065210		USE	107553	101158	47	5	BX TF 700
065216		USE	107622	101165		USE	103294
065217		USE	107623	101231		USE	288267
065225-N	59	69	AD9 12V - NEW	101234		USE	103081

# PRIOR AUTOMOTIVE PRODUCTS, LLC

## NUMERICAL LISTING AND INTERCHANGE

PART NO.	PAGE NO.	PICTURE REF.	DESCRIPTION OR INTERCHANGE NO. (H)-HEAD (B)-BLOCK (R)-RIGHT (L)-LEFT	PART NO.	PAGE NO.	PICTURE REF.	DESCRIPTION OR INTERCHANGE NO. (H)-HEAD (B)-BLOCK (R)-RIGHT (L)-LEFT
101240		USE	286171	101900-N	59	74	AD2 CARTRIDGE
101242		USE	281286	101904		USE	286591
101245		USE	279712	101905		USE	101487
101246		USE	229077	101910		USE	101860
101247		USE	283505	101911		USE	286544
101249		USE	289144	101912		USE	286544
101251		USE	287238	101936		USE	286591
101255		USE	101256	101964		USE	289789
101256	47	5	BX TF 700	101965		USE	289789
101266		USE	275317	101966		USE	101158
101267		USE	284744	101967		USE	13250
101268		USE	286539	101969		USE	289925
101273		USE	101282	101970		USE	289789
101279		USE	276781	101971		USE	289789
101280		USE	289349	101972		USE	101158
101282	47	5	BX TF 700	101974		USE	289925
101297		USE	287238	102000		USE	286539
101298		USE	287260	102001		USE	286591
101307		USE	286706	102002		USE	286585
101311	83	205	LQ-4 FRONT AXLE	102003		USE	286539
101344		USE	104086	102004		USE	286543
101363		USE	287564	102021		USE	289347
101378		USE	289925	102022		USE	102089
101387		USE	289342	102027	71	119	MV-2 - R&R Exch Only
101395		USE	276781	102037		USE	101158
101396		USE	286706	102038		USE	289350
101418		USE	101158	102039		USE	289339
101437-N	71	119	MV-2 Cntrl Mod	102040		USE	101158
101438		USE	101437	102041		USE	289350
101439		USE	101456	102042		USE	289339
101450	84	212	TR-3 Inversion Vlv	102052		USE	283828
101456	69	110	PP1 PushPull Cntrl	102065		USE	286581
101459		USE	101460	102077		USE	286596
101473		USE	288383	102078		USE	286596
101479		USE	286706	102088		USE	289688
101487-N	83	200	QR-1 VALVE	102089	47	5	BX TF 700
101519		USE	286584	102090		USE	286542
101528		USE	288605	102091		USE	286591
101545		USE	101554	102092		USE	286591
101552		USE	276725	102136		USE	289344
101554	47	5	BX TF 700	102137	47	5	BX TF 700
101556		USE	286554	102143		USE	289941
101575		USE	101589	102144		USE	103081
101576		USE	101590	102151		USE	289941
101588		USE	286595	102153		USE	101158
101589	47	5	BX TF 700	102154		USE	101158
101590	47	5	BX TF 700	102155		USE	101786
101608		USE	286546	102165		USE	102626
101622-N	81	189	SR4 TRAILER SPG.	102166		USE	102626
101633		USE	286543	102167		USE	229617
101635		USE	101636	102175		USE	289688
101636	47	5	BX TF 700	102176		USE	275176
101641		USE	286539	102177		USE	275176
101642		USE	276725	102179		USE	289688
101646		USE	101158	102180		USE	289158
101648		USE	289924	102181		USE	289688
101649		USE	289925	102186		USE	287238
101650		USE	289941	102187		USE	276781
101651		USE	101636	102191		USE	286706
101652		USE	286539	102192	70	115	PP-7 - R&R Exch Only
101656		USE	286543	102193		USE	289349
101661		USE	227390	102211		USE	102213
101783		USE	288644	102213	47	5	BX TF 700
101784		USE	287238	102231		USE	102213
101813		USE	101818	102232		USE	276781
101814		USE	101818	102237		USE	276270
101815		USE	288383	102267		USE	102290
101817		USE	101818	102273		USE	229617
101818-N	66	98	E-7 Dual Brk Vlv	102276		USE	102626
101820		USE	229617	102277		USE	102626
101836		USE	101781	102278		USE	102626
101849		USE	286706	102279		USE	102626
101850		USE	276781	102280		USE	102626
101861		USE	101884	102281		USE	102626
101873		USE	289688	102286		USE	289344
101884	47	5	BX TF 700	102289		USE	102290
101890	71	119	MV-2 - R&R Exch Only	102290	47	5	BX TF 700
101893		USE	286539	102302		USE	289925
101894		USE	286535	102305		USE	289349

# PRIOR AUTOMOTIVE PRODUCTS, LLC

## NUMERICAL LISTING AND INTERCHANGE

PART NO.	PAGE NO.	PICTURE REF.	DESCRIPTION OR INTERCHANGE NO. (H)-HEAD (B)-BLOCK (R)-RIGHT (L)-LEFT	PART NO.	PAGE NO.	PICTURE REF.	DESCRIPTION OR INTERCHANGE NO. (H)-HEAD (B)-BLOCK (R)-RIGHT (L)-LEFT
102308		USE	104087	102978		USE	101884
102327		USE	286584	102979		USE	289349
102328		USE	286584	102981		USE	103009
102388		USE	101860	102987		USE	102989
102396		USE	104041	102988		USE	102989
102405		USE	103211	102989	47	4	BX TF 501
102407		USE	103212	102991		USE	286563
102540		USE	101158	102997		USE	65060
102541		USE	289789	103009-N	73	128	R12 RELAY VALVE
102542		USE	289789	103010-N	74	135	R14 RELAY VALVE
102543		USE	101158	103022		USE	103010
102544		USE	286591	103028-N	74	134	R14 RELAY VALVE
102561		USE	102598	103037		USE	281751
102562		USE	106791	103038		USE	227406
102596		USE	102598	103039		USE	227407
102598	47	5	BX TF 700	103042		USE	289336
102604		USE	227406	103048		USE	103051
102611		USE	276725	103051	47	5	BX TF 700
102612		USE	275286	103061		USE	288497
102615		USE	102626	103071		USE	286591
102626-N	73	127	R12 RELAY VALVE	103072		USE	286591
102629		USE	289925	103073		USE	289688
102630		USE	101256	103081-N	74	137	R7 Modulating Vlv
102631		USE	289350	103087		USE	104149
102632		USE	101256	103097		USE	288605
102638		USE	288605	103116		USE	103212
102640		USE	286580	103117		USE	103211
102651		USE	286527	103130		USE	286581
102655		USE	285651	103139	74	135	R14
102656		USE	286584	103143		USE	286555
102658		USE	102697	103152		USE	289336
102674		USE	285651	103167		USE	103274
102688		USE	102698	103176		USE	288605
102691		USE	286584	103195	73	128	R12
102695		USE	102698	103211	47	1	BX 2150
102696		USE	102697	103212	47	1	BX 2150
102697	47	4	BX TF 501	103219		USE	65019
102698	47	4	BX TF 501	103223		USE	65019
102726		USE	102734	103248		USE	104039
102734	47	4	BX TF 501	103273		USE	103274
102742	47	4	BX TF 501	103274	47	4	BX TF 501
102743		USE	102742	103276		USE	103278
102761		USE	287376	103277		USE	103278
102764		USE	102742	103278	47	5	BX TF 700
102769		USE	102785	103289		USE	227406
102781		USE	286538	103294-N	74	135	R14
102784		USE	289342	103349		USE	104039
102785	47	4	BX TF 501	103350		USE	104039
102795		USE	104041	103351		USE	104039
102797		USE	286584	103353		USE	281946
102815		USE	103009	103718		USE	104041
102816		USE	103010	103756		USE	103757
102822		USE	286592	103757	69	110	PP-1 PushPull Vlv
102823		USE	102835	103773		USE	104042
102829		USE	227406	103792		USE	287418
102830		USE	227407	103819		USE	104042
102835	47	5	BX TF 700	103833-N	74	134	R14
102849		USE	103009	103835-N	74	135	R14
102850		USE	289348	103842		USE	106439
102851		USE	289348	103843		USE	106439
102852		USE	103009	103852		USE	229617
102854		USE	276781	103890		USE	286591
102855		USE	103010	103912-N	73	127	R12
102856		USE	103010	103918		USE	289925
102857		USE	103010	103952		USE	286539
102858		USE	103010	103968		USE	289340
102859		USE	103010	104001		USE	104102
102860		USE	103010	104002		USE	104103
102870		USE	102953	104021		USE	104041
102945		USE	289340	104031		USE	289688
102952		USE	279037	104032		USE	286591
102953	47	2	BX TF 400	104034		USE	286591
102954		USE	102953	104038		USE	104039
102964		USE	101158	104039	47	1	BX 2150
102965		USE	289350	104040		USE	104039
102966		USE	289339	104041	47	1	BX 2150
102967		USE	289925	104042	47	1	BX 2150
102968		USE	289925	104059		USE	104041
102969		USE	229617	104090		USE	65075

# PRIOR AUTOMOTIVE PRODUCTS, LLC

## NUMERICAL LISTING AND INTERCHANGE

PART NO.	PAGE NO.	PICTURE REF.	DESCRIPTION OR INTERCHANGE NO. (H)-HEAD (B)-BLOCK (R)-RIGHT (L)-LEFT	PART NO.	PAGE NO.	PICTURE REF.	DESCRIPTION OR INTERCHANGE NO. (H)-HEAD (B)-BLOCK (R)-RIGHT (L)-LEFT
104102	47	1	BX 2150	104854		USE	286585
104103	47	1	BX 2150	104962		USE	286560
104107		USE	284744	104963		USE	286555
104108		USE	106439	104977		USE	289348
104145		USE	104240	104978		USE	289340
104155		USE	104041	104979		USE	289340
104165-N	73	128	R12	106131		USE	285857
104168		USE	65019	106140		USE	228661
104176		USE	104189	106157		USE	286528
104188		USE	104189	106169		USE	286526
104189	47	5	BX TF 700	106240		USE	286538
104235		USE	65019	106265		USE	106268
104236		USE	104041	106268	47	5	BX TF 700
104240	69	110	PP-1 PushPull Vlv	106287		USE	106268
104245		USE	65060	106290		USE	286538
104248		USE	65075	106301		USE	286620
104274		USE	104322	106313		134	R14
104297	47	4	BX TF 501	106331	74	USE	65157
104305		USE	289340	106340		USE	286544
104306		USE	289340	106374		USE	286538
104307		USE	289340	106381		USE	106268
104322	47	4	BX TF 501	106401		USE	286582
104329		USE	103278	106439	47	1	BX 2150
104345	74	135	R14	106759		USE	286624
104347		USE	104348	106791	47	5	BX TF 700
104352		USE	276270	106792	47	5	BX TF 700
104356		USE	289342	106793	47	5	BX TF 700
104358-N	59	74	AD4 CART	106831		USE	286582
104384		USE	104418	106843		USE	284662
104390		USE	104419	106858		USE	289925
104416		USE	104418	106877		USE	107296
104417		USE	104419	106878		USE	107296
104418	47	4	BX TF 501	106879		USE	107526
104419	47	4	BX TF 501	106880		USE	107526
104425		USE	104041	106890		USE	106791
104430		USE	104041	106929		USE	65145
104431		USE	104041	106931		USE	65146
104436		USE	286526	106978	47	1	BX 2150
104437		USE	286528	106980		USE	286582
104465		USE	104473	106983		USE	106985
104473	47	4	BX TF 501	106984		USE	106985
104490		USE	286585	106985	47	1	BX 2150
104500		USE	104583	107000		USE	107506
104501		USE	104584	107001		USE	107507
104513	47	4	BX TF 501	107002		USE	107508
104514	47	4	BX TF 501	107003		USE	107509
104515		USE	104513	107004		USE	107510
104516		USE	104513	107005		USE	107511
104518		USE	104590	107006		USE	107512
104519		USE	104419	107007		USE	107513
104520		USE	104526	107008		USE	107514
104521		USE	104548	107023		USE	109604
104522		USE	104589	107042		USE	107622
104523		USE	104513	107043		USE	109604
104524		USE	104513	107051		USE	107623
104526	47	4	BX TF 501	107053		USE	109604
104528		USE	104514	107095		USE	107622
104548	47	4	BX TF 501	107096		USE	107623
104561		127	R12	107097		USE	107296
104574		USE	103010-N	107098		USE	107514
104583	48	12	BX TF 1400 L	107099		USE	107513
104584	48	12	BX TF 1400 L	107198		USE	107221
104585		USE	104583	107199		USE	107221
104586		USE	104584	107221	47	1	BX 2150
104589	47	4	BX TF 501	107238		USE	107296
104590	47	4	BX TF 501	107296	47	4	BX TF 501
104601		USE	289925	107494		USE	289915
104715		USE	289925	107495		USE	106793
104716		USE	106791	107506	48	7	BX TF 550
104720		USE	102989	107507	48	8	BX TF 750
104721		USE	102989	107508	48	8	BX TF 750
104744		USE	104041	107509	48	8	BX TF 550
104745		USE	104041	107510	48	8	BX TF 750
104746		USE	286582	107511	48	8	BX TF 550
104747		USE	106978	107512	48	8	BX TF 750
104841		USE	103211	107513	48	7	BX TF 550
104842		USE	103211	107514	48	7	BX TF 550
104843		USE	103212	107518		USE	107866
104844		USE	103212	107519		USE	107866

# PRIOR AUTOMOTIVE PRODUCTS, LLC

## NUMERICAL LISTING AND INTERCHANGE

PART NO.	PAGE NO.	PICTURE REF.	DESCRIPTION OR INTERCHANGE NO. (H)-HEAD (B)-BLOCK (R)-RIGHT (L)-LEFT	PART NO.	PAGE NO.	PICTURE REF.	DESCRIPTION OR INTERCHANGE NO. (H)-HEAD (B)-BLOCK (R)-RIGHT (L)-LEFT
107526	47	1	BX 2150	108213		USE	286552
107532		USE	286580	108214		USE	286580
107533		USE	286584	108215		USE	286593
107534		USE	286552	108216		USE	286584
107535		USE	103274	108218		USE	101884
107550		USE	107526	108219		USE	289336
107551		USE	107553	108220		USE	103278
107552		USE	107553	108221		USE	289907
107553	48	12	BX TF 1400 L	108222		USE	104583
107622	48	7	BX TF 550	108223		USE	104042
107623	48	8	BX TF 750	108236		USE	107981
107630		USE	65145	108237		USE	107981
107682		USE	104584	108238		USE	107813
107683		USE	289339	108247		USE	108261
107738		USE	107526	108248		USE	108260
107779		USE	107508	108260	47	1	BX 2150
107780		USE	107510	108261	47	1	BX 2150
107781		USE	107507	108271		USE	286578
107782		USE	107512	108272		USE	104473
107783		USE	107813	108273		USE	104473
107784		USE	107623	108277		USE	107514
107785		USE	107622	108295		USE	107512
107794-N	59	74	AD-9 CARTRIDGE - NEW	108334		USE	106439
107806		USE	109603	108335		USE	106439
107807		USE	109603	108447		USE	106439
107812		USE	107813	108448		USE	106439
107812		USE	107813	108456		USE	108110
107813	48	8	BX TF 750	108457		USE	108110
107819		USE	107507	108467		USE	108110
107819		USE	107507	108468		USE	108110
107820		USE	107507	108556		USE	108557
107820		USE	107507	108557	48	8	BX TF 750
107823		USE	107836	108583		USE	107506
107836	48	12	BX TF 1400 L	108584		USE	107507
107837		USE	107836	108588		USE	107514
107865		USE	107919	108589		USE	107514
107866	48	7	BX TF 550	108622		USE	289790
107867		USE	107869	108649		USE	106439
107868		USE	107869	108651		USE	107553
107869	48	8	BX TF 750	108727		USE	107526
107871		USE	107508	108729		USE	109603
107913		USE	107526	108730		USE	107981
107914		USE	107509	108732		USE	109604
107917	48	7	BX TF 550	108733		USE	107533
107918		USE	107919	108734		USE	108854
107919	47	1	BX 2150	108735		USE	108854
107946		USE	107526	108778		USE	108779
107974		USE	107506	108779	48	12	TF 1400
107975		USE	107506	108788		USE	108790
107979		USE	107981	108789		USE	108790
107980		USE	107981	108790	47	1	BX 2150
107981	48	7	BX TF 550	108803		USE	108804
108018		USE	107511	108804	48	7	BX TF 550
108065		USE	108066	108854	47	1	BX 2150
108066	48	7	BX TF 550	108859		USE	107514
108070		USE	286582	108864		USE	108866
108084		USE	107296	108865		USE	108866
108090		USE	107296	108866	48	7	BX TF 550
108094		USE	108096	108867		USE	108869
108096	48	12	BX TF 1400 L	108868		USE	108869
108108		USE	108110	108869	48	8	BX TF 750
108109		USE	108110	108924		USE	108110
108110	48	7	BX TF 550	108925		USE	106439
108111		USE	107514	108930		USE	286527
108112		USE	107514	108934		USE	108935
108193		USE	107981	108935	48	8	BX TF 750
108194		USE	107981	108936		USE	108937
108201		USE	227471	108937	48	7	BX TF 550
108202		USE	102674	108969		USE	107509
108203		USE	227407	108970		USE	286551
108204		USE	283533	108982		USE	108990
108205		USE	277731	108986		USE	107509
108206		USE	283996	108987		USE	107981
108207		USE	284003	108988		USE	109603
108208		USE	102742	108989		USE	109604
108209		USE	103274	108990	48	7	BX TF 550
108210		USE	107296	108991		USE	108992
108211		USE	286546	108992	48	8	BX TF 750
108212		USE	286549	109013		USE	108804

# PRIOR AUTOMOTIVE PRODUCTS, LLC

## NUMERICAL LISTING AND INTERCHANGE

PART NO.	PAGE NO.	PICTURE REF.	DESCRIPTION OR INTERCHANGE NO. (H)-HEAD (B)-BLOCK (R)-RIGHT (L)-LEFT	PART NO.	PAGE NO.	PICTURE REF.	DESCRIPTION OR INTERCHANGE NO. (H)-HEAD (B)-BLOCK (R)-RIGHT (L)-LEFT
109030		USE	108854	109591		USE	104583
109037		USE	286582	109603	48	7	BX TF 550
109045		USE	108790	109604	48	8	BX TF 750
109069		USE	104102	109626		USE	109552
109072		USE	104473	109633		USE	109659
109073		USE	104473	109646		USE	109647
109079		USE	108260	109647	48	7	BX TF 550
109087		USE	109088	109649		USE	109653
109088	48	7	BX TF 550	109653	48	7	BX TF 550
109110		USE	109111	109657		USE	109382
109111	48	8	BX TF 750	109659	48	8	BX TF 750
109113		USE	107526	109685		USE	065225-N
109114		USE	107526	109686		USE	5004341-H or S
109136		USE	107981	109687		USE	65226
109138		USE	109139	109688		USE	65227
109139	48	7	BX TF 550	109689		USE	65650
109141		USE	109142	109690		USE	65651
109142	48	8	BX TF 750	109691		USE	65652
109147	48	12	BX TF 1400 L	109695		USE	5004342-H or S
109174		USE	800632-N	109699		USE	107221
109197		USE	107506	109772		USE	65691
109198		USE	107507	109775		USE	65694
109201		USE	109219	109777		USE	109809
109212		USE	108804	109809	48	7	BX TF 550
109219	47	1	BX2150	109816		USE	109139
109250		USE	109251	109824		USE	109863
109251	48	7	BX TF 550	109860		USE	109139
109253		USE	107981	109861		USE	109139
109263		USE	286528	109863	48	8	BX TF 750
109264-N		130	R-12P	109864		USE	109863
109273		USE	107919	109867		USE	107622
109279		USE	109251	109868		USE	107623
109285		USE	109287	109872		USE	65691
109286		USE	109287	109873		USE	65694
109287	48	8	BX TF 750	109882		USE	107981
109319		USE	109139	109893		USE	131075
109320		USE	107508	109894		USE	131076
109321		USE	109139	109964		USE	109147
109322		USE	109142	109976		USE	800632-N
109335		USE	109251	109991		USE	65691
109336		USE	109287	109992		USE	65694
109348		USE	107553	109994-N	60	76	AD-SP Dryer Cart. - NEW
109360		USE	107221	109995	60	77A	AD-SP PurgeVlv Kit
109367		USE	107981	10R9393		no pic	EL365
109380		USE	104102	110120		USE	110147
109383		USE	109382	110126		USE	110139
109425	48	7	BX TF 550	110139-N	78	161	Sealco Ratio Relay
109426	48	8	BX TF 750	110140		USE	110147
109429		USE	109425	110155		USE	9125
109430		USE	109426	110170-N	80	184	Sealco Ratio Relay
109450		USE	109451	110171-N	80	184	Sealco Ratio Relay
109451	48	7	BX TF 550	110180		USE	110170
109465		USE	65612	110190		USE	110170
109466		USE	65613	110191-N	80	184	Sealco Ratio Relay
109469		USE	65612	110192		USE	110191
109470		USE	65613	110193		USE	110191
109477		USE	65612	110198		USE	110197
109477		USE	65612	110199		USE	110197
109478		USE	65613	110200-N	78	162	Sealco Ratio Relay
109478		USE	65613	110205-N	78	162	Sealco Ratio Relay
109493	61	79	CARTRIDGE AD-IP	110207		USE	110228
109494	61	78A	AD-IP Chk Vlv Kit	110230		USE	110171
109495	60	77B	AD-IS/SP 12V Kit	110265		USE	110400
109500		USE	65693	110267		USE	110338
109503		USE	65693	110268		USE	110470
109503		USE	65693	110275		USE	110197
109522		USE	107981	110305		USE	110171
109542		USE	109603	110310	80	184	Sealco Ratio Relay
109543		USE	109603	110311		USE	110310
109544		USE	109603	110312		USE	110310
109545		USE	109604	110315	80	184	Sealco Ratio Relay
109546		USE	109604	110316		USE	110315
109547		USE	109604	110317		USE	110315
109551		USE	109552	110325		USE	110400
109552	48	8	BX TF 750	110330		USE	110400
109569		USE	5004341-H or S	110335		USE	110400
109570		USE	5004342-H or S	110340		USE	110400
109578	59	73	AD-9 Thrmo Kit	110345		USE	110400
109579	59	73	AD-9 Thrmo Kit	110380	78	165	Sealco Ratio Relay

# PRIOR AUTOMOTIVE PRODUCTS, LLC

## NUMERICAL LISTING AND INTERCHANGE

PART NO.	PAGE NO.	PICTURE REF.	DESCRIPTION OR INTERCHANGE NO. (H)-HEAD (B)-BLOCK (R)-RIGHT (L)-LEFT	PART NO.	PAGE NO.	PICTURE REF.	DESCRIPTION OR INTERCHANGE NO. (H)-HEAD (B)-BLOCK (R)-RIGHT (L)-LEFT
110385	78	165	Sealco Ratio Relay	226342		USE	225700
110415	78	165	Sealco Ratio Relay-NEW	226363		USE	275200
110416	78	165	Sealco Ratio Relay	226364		USE	227406
110425		USE	110400	226365		USE	227401
110430		USE	110400	226366		USE	227322
110435		USE	110400	226411	86	227	SL3 STOP LITE SW
110440		USE	110400	226431		USE	275200
110445		USE	110400	226433		USE	227405
110460	78	162	Sealco Ratio Relay	226434		USE	227401
110470	78	162	Sealco Ratio Relay	226435		USE	228138
110500-N	80	185	Sealco Sprng Brk	226436		USE	227320
110700-N	80	186	Sealco Sprng Brk	226437		USE	227322
110800-N	80	186	Sealco Sprng Brk	226438		USE	227325
111170		USE	110170	226445		USE	227322
111171		USE	110171	226454		USE	228268
111180		USE	110170	226463		USE	227401
111190		USE	110170	226466		USE	227326
111191		USE	110191	226467		USE	227326
111192		USE	110191	226468		USE	227326
111193		USE	110191	226479		USE	227412
111230		USE	110171	226482		USE	227415
111305		USE	110171	226485		USE	227411
112170		USE	110170	226499		USE	276962
112171		USE	110171	226517		USE	227332
112180		USE	110170	226518		USE	227401
112190		USE	110170	226519		USE	227401
112191		USE	110191	226520		USE	227401
112192		USE	110191	226523		USE	227322
112193		USE	110191	226526		USE	227320
112230		USE	110171	226527		USE	227322
112305		USE	110171	226528		USE	227322
12352-N	77	152	Mid Multi Fnctn	226529		USE	227322
131038		USE	65612	226531		USE	227408
131066		USE	65612	226534		USE	227413
131075	48	7	BX TF 550	226535	47	3	BX TF 500
131076	48	8	BX TF 750	226536		USE	228269
131080		USE	65612	226538	47	3	BX TF 500
205000-N	83	200	QRV QUICK RELEAS	226549		USE	227415
205105-N	86	231	ST-1 Safety Vlv	226550		USE	228140
215186		USE	223578	226557		USE	227403
215356		USE	224491	226558		USE	227403
217383		USE	227355	226562		USE	227402
217698	85	222	TRANSFER VALVE	226576		USE	227326
221992		USE	229844	226654		USE	228268
222894		USE	227360	226656		USE	228370
223053		USE	227355	226657		USE	228371
223821	83	203	LQ2 LIM QUICK RE	226659		USE	227401
223871		USE	223220	226664		USE	227322
223887		USE	224491	226685		USE	227321
223916		USE	224491	226686		USE	227322
224175		USE	227360	226687		USE	228140
224193		USE	227360	226688		USE	227405
224196		USE	227355	226689		USE	227404
224197		USE	227356	226695		USE	227325
224198		USE	227357	226705		USE	227402
225211		USE	227357	226706		USE	227403
225375		USE	229617	226711		USE	228140
225433	83	203	LQ2 QUICK RELEA	226716		USE	227405
225480		USE	225433	226717		USE	227320
225700		no pic	BX TF 300	226719	47	2	BX TF 400
225754		USE	227471	226720		USE	227414
225841		no pic	BX TF 300	226725		USE	228138
225892		USE	229617	226726		USE	228353
226085		USE	227405	226727		USE	227402
226086		USE	227320	226728		USE	228140
226090		USE	227326	226749		USE	227412
226156		USE	228140	226755		USE	227402
226262		USE	226411	226760		USE	227405
226263		USE	226411	226766		USE	227322
226278		USE	227320	226767		USE	227322
226279		USE	227322	226777		USE	227327
226280		USE	227322	226815		USE	228140
226282		USE	228139	226816		USE	227321
226286		USE	227321	226829		USE	227407
226287		USE	228353	226836		USE	228429
226288		USE	276961	226849	47	2	BX TF 400
226335		USE	227403	226855		USE	228371
226339		USE	227321	226862		USE	276961
226341		USE	227471	226868	47	2	BX TF 400

# PRIOR AUTOMOTIVE PRODUCTS, LLC

## NUMERICAL LISTING AND INTERCHANGE

PART NO.	PAGE NO.	PICTURE REF.	DESCRIPTION OR INTERCHANGE NO. (H)-HEAD (B)-BLOCK (R)-RIGHT (L)-LEFT	PART NO.	PAGE NO.	PICTURE REF.	DESCRIPTION OR INTERCHANGE NO. (H)-HEAD (B)-BLOCK (R)-RIGHT (L)-LEFT
226890		USE	227413	227410	47	2	BX TF 400
226893		USE	227402	227411	47	2	BX TF 400
226935		USE	225834	227412	47	2	BX TF 400
226944		USE	228429	227413	47	2	BX TF 400
226945		USE	228429	227414	47	2	BX TF 400
226947		USE	278141	227415	47	2	BX TF 400
226948		USE	227402	227417	47	2	BX TF 400
226949	47	2	BX TF 400	227421		USE	227406
226978		USE	277440	227422		USE	228361
226981	47	2	BX TF 400	227428		USE	228362
226982		USE	226981	227431		USE	227406
226984		USE	227405	227435		USE	275200
226990		USE	228140	227438		USE	228344
227001	47	2	BX TF 400	227440	47	3	BX TF 500
227029		USE	227331	227446	47	2	BX TF 400
227030		USE	228429	227450		USE	227321
227042		USE	227322	227451		USE	229078
227044		USE	227440	227465		no pic	BX TF 300
227047		USE	227402	227471		no pic	BX TF 300
227049		USE	228140	227480		USE	227414
227089		USE	227409	227481		USE	225700
227094		USE	228269	227487		USE	227322
227110		USE	227403	227503		USE	228510
227121		USE	275200	227516		USE	229617
227138		USE	227411	227538		USE	228138
227139		USE	227411	227544		USE	228139
227140		USE	227325	227546		USE	229077
227155		USE	224401	227548		USE	227402
227156		USE	227321	227551		USE	227402
227167		USE	228429	227552		USE	228140
227171		USE	227403	227557		USE	228449
227177		USE	227407	227559		USE	277446
227194		USE	228448	227563		USE	227403
227195		USE	228443	227565		USE	227320
227206		USE	227410	227579		USE	276961
227207		USE	227331	227584		USE	227408
227208		USE	227332	227585		USE	228140
227216		USE	227328	227587	47	2	BX TF 400
227220		USE	227405	227606		USE	229532
227226	47	2	BX TF 400	227655		USE	227321
227227		USE	227405	227675		USE	228139
227247		USE	228354	227676		USE	227321
227250		USE	228661	227699	86	227	SL3 STOP LITE SW
227259		USE	228429	227724		USE	227321
227274		USE	227322	227738		USE	227406
227275		USE	227406	227739		USE	227402
227279		USE	227401	227740		USE	228141
227282		USE	228429	227741		USE	228140
227284		USE	227403	227773		USE	228430
227299		USE	227406	227789		USE	228447
227318		USE	227406	227790		USE	228443
227320	47	3	BX TF 500	227791		USE	227332
227321	47	3	BX TF 500	227792		USE	228268
227322	47	3	BX TF 500	227793		USE	227408
227323		USE	228140	227799		USE	228269
227324	47	3	BX TF 500	227817		USE	228479
227325	47	3	BX TF 500	227818		USE	228429
227326	47	3	BX TF 500	227819		USE	227412
227327	47	3	BX TF 500	227855		USE	225700
227328	47	3	BX TF 500	227864	47	2	BX TF 400
227329		USE	276962	227870-N		232	BW SC-1 3/8" CK VALVE
227330		USE	276961	227871-N		232	BW SC-3 1/2" CK VALVE
227331	47	3	BX TF 500	227872		USE	227403
227332	47	3	BX TF 500	227894		USE	227699
227358		USE	227357	227905		USE	228346
227359		USE	227355	227917		USE	227471
227361		USE	227360	227920	47	2	BX TF 400
227389		USE	228429	227928		USE	276962
227390	47	2	BX TF 400	227929		USE	228364
227400		USE	227405	227936		USE	228141
227401	47	2	BX TF 400	227954		USE	227412
227402	47	2	BX TF 400	227970		USE	227401
227403	47	2	BX TF 400	228036		USE	227320
227404	47	2	BX TF 400	228048		USE	228429
227405	47	2	BX TF 400	228054		USE	228141
227406	47	2	BX TF 400	228058		USE	276962
227407	47	2	BX TF 400	228072		USE	227471
227408	47	2	BX TF 400	228080		USE	228362
227409	47	2	BX TF 400	228083		USE	228451

# PRIOR AUTOMOTIVE PRODUCTS, LLC

## NUMERICAL LISTING AND INTERCHANGE

PART NO.	PAGE NO.	PICTURE REF.	DESCRIPTION OR INTERCHANGE NO. (H)-HEAD (B)-BLOCK (R)-RIGHT (L)-LEFT	PART NO.	PAGE NO.	PICTURE REF.	DESCRIPTION OR INTERCHANGE NO. (H)-HEAD (B)-BLOCK (R)-RIGHT (L)-LEFT
228093		USE	228350	228349		USE	227327
228094		USE	228351	228350	47	3	BX TF 500
228102		USE	228140	228351	47	3	BX TF 500
228103		USE	227401	228352	47	3	BX TF 500
228117		USE	228352	228353	47	3	BX TF 500
228124		USE	227406	228354	47	3	BX TF 500
228128		USE	228451	228355		USE	227326
228137		USE	227402	228356		USE	227328
228138	47	2	BX TF 400	228357		USE	227440
228139	47	3	BX TF 500	228358		USE	227440
228140	47	3	BX TF 500	228359		USE	228139
228141	47	3	BX TF 500	228360		USE	228139
228153		USE	228366	228361	47	3	BX TF 500
228169		USE	227406	228362	47	3	BX TF 500
228176		USE	227406	228363		USE	228479
228177		USE	227407	228364	47	3	BX TF 500
228192		USE	229078	228365		USE	228362
228203	47	2	BX TF 400	228366	47	3	BX TF 500
228205		USE	229077	228367		USE	229078
228224		USE	228430	228368		USE	229078
228228	47	3	BX TF 500	228369		USE	227322
228255		USE	227407	228370	47	3	BX TF 500
228256		USE	227407	228371	47	3	BX TF 500
228266		USE	228443	228373		USE	276962
228267		USE	227332	228399	47	2	BX TF 400
228268	47	3	BX TF 500	228417		USE	228141
228269	47	3	BX TF 500	228421		USE	276962
228270		USE	227331	228426		USE	227321
228271		USE	227332	228435	47	3	BX TF 500
228287	47	3	BX TF 500	228439	47	3	BX TF 500
228300		USE	228661	228443	47	3	BX TF 500
228301		USE	276962	228446		USE	276962
228302		USE	227320	228447	47	3	BX TF 500
228303		USE	228140	228448	47	3	BX TF 500
228304		USE	227322	228449	47	3	BX TF 500
228305		USE	228140	228450		USE	227320
228306		USE	227321	228451	47	2	BX TF 400
228307		USE	227320	228459		USE	228140
228308		USE	227322	228478	47	2	BX TF 400
228309		USE	228140	228479	47	3	BX TF 500
228310		USE	227322	228482		USE	228140
228311		USE	227322	228485		USE	283935
228312		USE	227321	228486		USE	227322
228313		USE	227322	228500		USE	228510
228314		USE	227321	228503		USE	227405
228315		USE	227321	228596		USE	227405
228316		USE	227321	228600-N	86	227	SL4 STOP LITE SW
228317		USE	227320	228610		USE	227406
228318		USE	227321	228645		USE	227320
228319		USE	227322	228657		USE	275200
228320		USE	227320	228661	47	3	BX TF 500
228321		USE	227322	228670		USE	227403
228322		USE	227322	228671		USE	227321
228323		USE	227322	228687	86	227	SL4 STOP LITE SW
228324		USE	227322	228688		USE	228600
228325		USE	228140	228729		USE	229617
228326		USE	228140	228750-N	86	230	LP3 Low Press Ind
228327		USE	228140	228762		USE	283935
228328		USE	228140	228765		USE	227406
228329		USE	227321	228766		USE	228141
228330		USE	227320	228767		USE	227406
228331		USE	228140	228768		USE	228141
228332		USE	276961	228771		USE	227414
228333		USE	276962	228775		USE	227322
228334		USE	276962	228789		USE	228443
228335		USE	276961	228826		USE	227322
228336		USE	227325	228827		USE	227405
228337		USE	227325	228828		USE	227320
228338		USE	227325	228835		USE	229525
228339		USE	228140	228841		no pic	BX TF 300
228340		USE	228140	228843		USE	225834
228341		USE	228140	228848		USE	227322
228342		USE	228140	228849		USE	227407
228343		USE	228141	228850		USE	227406
228344	47	3	BX TF 500	228852		USE	228429
228345		USE	228141	228858		USE	227471
228346	47	3	BX TF 500	228879		USE	276961
228347		USE	228141	228880		USE	276961
228348		USE	228141	228898	47	2	BX TF 400

# PRIOR AUTOMOTIVE PRODUCTS, LLC

## NUMERICAL LISTING AND INTERCHANGE

PART NO.	PAGE NO.	PICTURE REF.	DESCRIPTION OR INTERCHANGE NO. (H)-HEAD (B)-BLOCK (R)-RIGHT (L)-LEFT	PART NO.	PAGE NO.	PICTURE REF.	DESCRIPTION OR INTERCHANGE NO. (H)-HEAD (B)-BLOCK (R)-RIGHT (L)-LEFT
228902		USE	227403	229532	47	2	BX TF 400
228906		USE	227403	229541		USE	227320
228916		USE	227408	229543		USE	227321
228917		USE	229544	229544	47	3	BX TF 500
228918		USE	227321	229562	47	3	BX TF 500
228949		USE	229562	229563		USE	276961
228954		USE	228141	229569		USE	227403
228955		USE	205000	229570		USE	228443
228956		USE	227321	229575		USE	228510
228971		USE	227322	229604		USE	229617
228972		USE	225834	229605		USE	229617
228976		USE	227409	229606		USE	229617
228977		USE	227322	229608	79	179	TW1 DASH CONTROL
228988		USE	227326	229613		USE	276635
228989		USE	227328	229614		USE	276635
228990		USE	227415	229615		USE	276635
228991		USE	227402	229616		USE	276635
228999		USE	228141	229617-N	79	179	TW1 DASH CONTROL
229000	48	11	BX TF 1000	229620		USE	229617
229001	48	11	BX TF 1000	229621		USE	229617
229013		USE	227406	229622		USE	229617
229017		USE	227410	229623		USE	229617
229020		USE	227408	229624		USE	229617
229031		USE	227331	229625		USE	229617
229032		USE	227332	229626		USE	229617
229056		USE	227402	229627		USE	229617
229057	47	2	BX TF 400	229628		USE	229617
229058		USE	227321	229629		USE	229617
229059	47	3	BX TF 500	229631		USE	229617
229062		USE	228140	229632		USE	229617
229077	47	2	BX TF 400	229633		USE	229617
229078	47	3	BX TF 500	229634		USE	229617
229079		USE	227406	229635		USE	229617
229080		USE	227406	229636		USE	229617
229081		USE	227406	229637		USE	229617
229086		USE	228140	229638		USE	229617
229087		USE	228140	229639		USE	229617
229088		USE	228140	229640		USE	229617
229089		USE	228141	229641		USE	229617
229090		USE	228141	229651		USE	227471
229091		USE	228141	229655		USE	227321
229092		USE	227402	229666		USE	276269
229093		USE	227402	229668		USE	228140
229094		USE	227402	229669		USE	227406
229095		USE	229844	229670		USE	227402
229096		USE	227403	229671		USE	228141
229110		USE	228510	229672		USE	228140
229144	47	3	BX TF 500	229681	47	3	BX TF 500
229154	47	2	BX TF 400	229690		USE	229617
229159		USE	227402	229693		USE	229617
229160		USE	228140	229694		USE	276961
229164		USE	228139	229695		USE	276962
229183		USE	227402	229726	47	2	BX TF 400
229184		USE	227406	229732		USE	228510
229185		USE	227414	229754		USE	229144
229186		USE	227390	229768		USE	227326
229187		USE	227446	229774		USE	227403
229222		USE	276962	229775		USE	227414
229433		USE	228430	229776		USE	227321
229434		USE	228510	229787		USE	227390
229439		USE	227321	229790		USE	228140
229440		USE	228140	229793		USE	283935
229451		USE	227406	229800		USE	229501
229458		USE	227326	229803		USE	228510
229460		USE	227402	229804		USE	228510
229461		USE	227403	229810		USE	229617
229470		USE	276961	229813-N	83	200	QR1 VALVE
229476		USE	227321	229825		USE	227406
229483		USE	228510	229826	48	11	BX TF 1000
229491		USE	227414	229839		USE	229826
229500	65	93	E2 BRAKE VALVE-NEW	229843	47	3	BX TF 500
229501	65	93	E2 BRAKE VALVE-NEW	229844-N	83	200	QR1 VALVE
229505-N	83	203	LQ2 QUICK RELEA	229859-N	83	200	QR1 VALVE
229507	83	203	LQ2 QUICK RELEA	229860-N	83	200	QR1 VALVE
229509	83	203	LQ2 QUICK RELEA	229861	47	3	BX TF 500
229523		USE	229500	229895		USE	276974
229524		USE	229501	229898		USE	227412
229525	47	3	BX TF 500	229989		USE	229501
229531		USE	227412	229990		USE	275286

# PRIOR AUTOMOTIVE PRODUCTS, LLC

## NUMERICAL LISTING AND INTERCHANGE

PART NO.	PAGE NO.	PICTURE REF.	DESCRIPTION OR INTERCHANGE NO. (H)-HEAD (B)-BLOCK (R)-RIGHT (L)-LEFT	PART NO.	PAGE NO.	PICTURE REF.	DESCRIPTION OR INTERCHANGE NO. (H)-HEAD (B)-BLOCK (R)-RIGHT (L)-LEFT
229996		USE	229501	275509		USE	276270
229999		USE	229617	275514	47	3	BX TF 500
23511334		USE	107622	275524		USE	229501
23517103		USE	NT7031B	275544		USE	229501
23522123		USE	109426	275550		USE	227471
272921		USE	289347	275553		USE	229501
274726		USE	276781	275556		USE	229501
275000		USE	229501	275568		USE	277122
275007		USE	276962	275578		USE	228443
275025		USE	228477	275700	47	3	BX TF 500
275039		USE	276961	275701		USE	227406
275046		USE	227471	275702		USE	227407
275047		USE	227407	275703		USE	227407
275048		USE	227407	275707		USE	275200
275049		USE	227321	275714		USE	227407
275050		USE	228140	275719		USE	226411
275056		USE	229501	275721		USE	228165
275059		USE	227326	275725	48	11	BX TF 1000
275063	47	2	BX TF 400	275728		USE	227471
275070		USE	228140	275729		USE	228443
275102		USE	229500	275735		USE	227471
275107		USE	276270	275740		USE	228510
275108		USE	228510	275742		USE	276272
275109		USE	228140	275743		USE	277000
275111		USE	227321	275745		USE	228510
275113		USE	227471	275748		USE	228510
275114		USE	227471	275751		USE	227402
275115		USE	227471	275752		USE	228140
275116		USE	225700	275777	47	3	BX TF 500
275117		USE	225841	275781		USE	227401
275133		USE	228140	275782		USE	276781
275146		USE	229467	275784		USE	227402
275147		USE	229467	275786		USE	228140
275153		USE	228520	275791		USE	276781
275166		USE	277901	275792		USE	275250
275169		USE	229525	275793		USE	275250
275170		USE	229000	275796		USE	276781
275175-N	69	110	PP1 PUSH PULL	275799		USE	226411
275176-N	69	110	PP1 PUSH PULL	275800		USE	277446
275185		USE	227446	275803		USE	227446
275190		USE	229077	275804		USE	228366
275200-N	65	91	D2 GOVERNOR - NEW	275805		USE	229077
275203		USE	229826	275806		USE	229078
275209		USE	227409	275807		USE	228661
275217		USE	227406	275808		USE	228451
275231	47	3	BX TF 500	275817		USE	228287
275241		USE	229501	275829		USE	229617
275242		USE	278998	275830		USE	276476
275250	69	111	PP-2 - R&R - Exch. Only	275833		USE	226849
275260		USE	229078	275834	47	3	BX TF 500
275271	47	3	BX TF 500	275836		USE	228140
275286	48	11	BX TF 1000	275844		USE	275250
275308		USE	228841	275857		USE	276961
275315		USE	228510	275886		USE	228140
275316		USE	228661	275887		USE	228140
275317		2	BX TF 400	275934		USE	228451
275318		USE	275514	275973	47	2	BX TF 400
275322		USE	228451	275974		USE	227471
275345		USE	229617	275989		USE	227401
275346		USE	229617	275990		USE	228364
275347		USE	229617	275991		USE	227322
275349		USE	227322	276001		USE	227410
275350		USE	227401	276002		USE	227331
275351		USE	228140	276003		USE	227332
275352		USE	275286	276004		USE	276569
275360		USE	228510	276051		USE	227409
275391		USE	227402	276067		USE	228140
275392		USE	228140	276079		USE	229500
275400		USE	228510	276089		USE	227322
275404		USE	227326	276090		USE	227321
275406		USE	229501	276092		USE	228140
275409		USE	229562	276109		USE	275063
275415		USE	227322	276110		USE	228346
275423		USE	277808	276111		USE	276961
275433		USE	228140	276112		USE	228140
275434		USE	283040	276113		USE	227321
275471		USE	227413	276136		USE	276166
275491		USE	275200	276143		USE	227401
275494		USE	275317	276148		USE	227321

# PRIOR AUTOMOTIVE PRODUCTS, LLC

## NUMERICAL LISTING AND INTERCHANGE

PART NO.	PAGE NO.	PICTURE REF.	DESCRIPTION OR INTERCHANGE NO. (H)-HEAD (B)-BLOCK (R)-RIGHT (L)-LEFT	PART NO.	PAGE NO.	PICTURE REF.	DESCRIPTION OR INTERCHANGE NO. (H)-HEAD (B)-BLOCK (R)-RIGHT (L)-LEFT
276149		USE	283935	276782		USE	227401
276160		USE	227672	276786		USE	227322
276161		USE	227661	276791		USE	227404
276163		USE	228510	276802		USE	278998
276166	47	2	BX TF 400	276831	47	2	BX TF 400
276167		USE	276961	276833	47	2	BX TF 400
276168		USE	228451	276834		USE	228141
276169		USE	276166	276835		USE	228346
276177		USE	229505	276836		USE	228346
276179		USE	229507	276840		USE	228140
276182		USE	278998	276843		USE	276961
276186		USE	283935	276879		USE	228140
276202		USE	226411	276883		USE	227322
276220		USE	276476	276911	47	2	BX TF 400
276236		USE	277730	276912		USE	275063
276257		USE	227326	276913		USE	227321
276258		USE	227328	276915		USE	276962
276259		USE	229562	276923		USE	229617
276260		USE	227326	276946	47	3	BX TF 500
276290		USE	228600	276951		USE	228443
276306		USE	227327	276952		USE	228443
276308		USE	229544	276961	47	3	BX TF 500
276309		USE	228140	276962	47	3	BX TF 500
276310		USE	275317	276969		USE	227322
276323		USE	227401	276971	47	3	BX TF 500
276324	48	11	BX TF 1000	276974	47	3	BX TF 500
276330		USE	229501	276978	47	3	BX TF 500
276333		USE	278998	276985		USE	229544
276337		USE	227322	277015		USE	275175
276360		USE	227405	277016		USE	228443
276361		USE	227332	277023		USE	229501
276374		USE	228050	277025		USE	228140
276376		USE	228520	277028		USE	228477
276377		USE	228520	277029		USE	276569
276378		USE	227322	277055		USE	227405
276379		USE	227322	277056		USE	227401
276384		USE	227402	277057		USE	227320
276387		USE	229154	277058		USE	227322
276388		USE	227401	277065		USE	277101
276389		USE	227401	277072		USE	275175
276408		USE	229000	277073		USE	227471
276409		USE	229826	277082		USE	227405
276410		USE	227406	277099		USE	227417
276424		USE	229617	277111		USE	229525
276441		USE	229617	277122	47	3	BX TF 500
276442		USE	229617	277127		USE	227446
276455		USE	276635	277128		USE	228366
276462		USE	275250	277129		USE	281946
276463		USE	275250	277130		USE	227405
276475		USE	228661	277139		USE	229617
276476	47	3	BX TF 500	277140		USE	229617
276478	47	3	BX TF 500	277147-N	84	215	PR2 PRESS PRO
276517		USE	227321	277148-N	84	215	PR2 PRESS PRO
276520		USE	276273	277181	47	3	BX TF 500
276538		USE	275250	277185		USE	277446
276550		USE	227402	277186		USE	277446
276562		USE	275725	277187		USE	277446
276562		USE	276781	277188		USE	277446
276566		USE	275175	277189		USE	277446
276567		USE	275176	277198	47	3	BX TF 500
276569	69	110	PP1 PUSH PULL	277219		USE	228140
276580		USE	275175	277226	84	215	PR2 PRESS PRO
276581		USE	276781	277227-N	84	215	PR2 PRESS PRO
276583		USE	276569	277241		USE	276961
276584		USE	277731	277242		USE	276962
276597		USE	229544	277248		USE	227401
276600		USE	229525	277249		USE	227322
276615		USE	275286	277250		USE	227322
276635	79	182	TW4 DASH CNTRL-NEW	277252		USE	227403
276642		USE	229525	277255		USE	227321
276755		USE	276775	277287		USE	279000
276765		USE	227326	277334		USE	227321
276769		USE	278998	277342		USE	227401
276775	47	2	BX TF 400	277343		USE	227401
276776		USE	276775	277344		USE	227401
276777		USE	275725	277345		USE	228140
276778		USE	276911	277346		USE	228140
276779		USE	228477	277347		USE	228140
276780		USE	228477	277348		USE	228140

# PRIOR AUTOMOTIVE PRODUCTS, LLC

## NUMERICAL LISTING AND INTERCHANGE

PART NO.	PAGE NO.	PICTURE REF.	DESCRIPTION OR INTERCHANGE NO. (H)-HEAD (B)-BLOCK (R)-RIGHT (L)-LEFT	PART NO.	PAGE NO.	PICTURE REF.	DESCRIPTION OR INTERCHANGE NO. (H)-HEAD (B)-BLOCK (R)-RIGHT (L)-LEFT
277386		USE	227320	278141	47	3	BX TF 500
277390		USE	277446	278342		USE	227331
277395		USE	227405	278345		USE	283935
277397		USE	227320	278346		USE	277000
277398		USE	227320	278352		USE	278998
277399		USE	227320	278381		USE	278416
277400		USE	227322	278382		USE	278452
277422		USE	228510	278396		USE	227332
277440	47	3	BX TF 500	278399		USE	227415
277444		USE	277446	278400		USE	227415
277445		USE	277446	278405		USE	227320
277451	47	3	BX TF 500	278414		USE	227414
277456		USE	229501	278416	47	2	BX TF 400
277462		USE	228228	278417		USE	275250
277463		USE	276961	278425	70	113	PP4 PUSH PULL
277471		no pic	BX TF 300	278428		USE	276781
277472		USE	229501	278429		USE	227321
277503		USE	228510	278433	47	3	BX TF 500
277516		USE	229617	278434		USE	229501
277559		USE	277446	278445	47	3	BX TF 500
277560		USE	275777	278450	69	110	PP-1
277577	47	3	BX TF 500	278452	47	3	BX TF 500
277581		USE	229077	278453		USE	278452
277582		USE	227401	278462		USE	275250
277583		no pic	BX TF 300	278469		USE	227401
277589		USE	276569	278481		USE	101647
277617		USE	277471	278482		USE	229844
277622		USE	227322	278483	83	200	QR1 VALVE
277624		USE	227332	278484		USE	227471
277636		USE	227404	278501		USE	228140
277637		USE	228140	278503		USE	227403
277645		USE	275231	278525		USE	229617
277646		USE	227414	278534		USE	227406
277647		USE	228287	278554		USE	227406
277663		USE	276781	278555		USE	227405
277672		USE	227327	278556		USE	227402
277673		USE	227322	278557		USE	227320
277675		USE	227321	278558		USE	227322
277686		USE	276961	278559		USE	227322
277693		USE	227321	278560		USE	228364
277694	47	3	BX TF 500	278561		USE	228364
277718		USE	276781	278562		USE	275725
277730	47	3	BX TF 500	278570		USE	276635
277731	47	3	BX TF 500	278595	85	224	DC4 DBL. CK. VALV
277733		USE	277731	278596	85	224	DC4 DBL. CK. VALV
277734		USE	227471	278597	85	224	DC4 DBL. CK. VALV
277735		USE	227471	278598-N	85	224	DC4 DBL. CK. VALV
277736		USE	227471	278600		USE	278604
277737		USE	227321	278601		USE	278605
277738		USE	227327	278602		USE	278606
277739	47	3	BX TF 500	278603		USE	278607
277742		USE	228140	278604	47	3	BX TF 500
277743		USE	228140	278605	47	3	BX TF 500
277744		USE	275286	278606	47	3	BX TF 500
277745		USE	275286	278607	47	3	BX TF 500
277785		USE	228140	278608		USE	278604
277794		USE	277799	278609		USE	278605
277799	47	2	BX TF 400	278610		USE	278606
277801		USE	227403	278611		USE	278607
277802		USE	227321	278614-N	85	223	DC4 DBL. CK. VALV
277803		USE	227402	278615-N	85	223	DC4 DBL. CK. VALV
277804		USE	227321	278630		USE	277730
277808	47	2	BX TF 400	278631		USE	277731
277844		USE	227321	278646	47	2	BX TF 400
277855	47	2	BX TF 400	278654		USE	278998
277863		USE	278998	278655		USE	278998
277878		USE	283805	278659		USE	227331
277885		USE	225700	278681	47	3	BX TF 500
277886		USE	225841	278790		USE	227332
277890		USE	227331	278799		USE	278443
277897		USE	275250	278806		USE	227321
277898		USE	229493	278810		USE	277730
277901	47	3	BX TF 500	278811		USE	277731
277903		USE	283805	278812		USE	277730
277935		USE	227402	278813		USE	277731
277937		USE	227390	278820		USE	277446
277953		USE	283935	278821		USE	279159
277997		USE	283935	278827		USE	228140
277999		USE	276781	278858	47	2	BX TF 400

# PRIOR AUTOMOTIVE PRODUCTS, LLC

## NUMERICAL LISTING AND INTERCHANGE

PART NO.	PAGE NO.	PICTURE REF.	DESCRIPTION OR INTERCHANGE NO. (H)-HEAD (B)-BLOCK (R)-RIGHT (L)-LEFT	PART NO.	PAGE NO.	PICTURE REF.	DESCRIPTION OR INTERCHANGE NO. (H)-HEAD (B)-BLOCK (R)-RIGHT (L)-LEFT
278881		USE	277694	279405		USE	277446
278952		USE	227407	279407		USE	227322
278953		USE	278998	279416-N	86	230	LP3 LOW PRESSURE
278955	47	3	BX TF 500	279417		USE	275250
278963		USE	277000	279429		USE	276781
278968		USE	228287	279468		USE	275250
278969		USE	228141	279469		USE	276781
278997		USE	278998	279478		USE	276781
278998-N	65	94	E3 FOOT VALVE	279483	47	3	BX TF 500
279000-N	82	194	TP3 TRACTOR PROT	279505		USE	277147
279005		USE	277694	279512		USE	227402
279006		USE	277694	279522		USE	279556
279008		USE	276961	279525	48	11	BX TF 1000
279009	47	3	BX TF 500	279526		USE	275286
279014		USE	278998	279527		USE	276270
279022		USE	279150	279549		USE	277446
279023		USE	279150	279556	47	3	BX TF 500
279024	47	2	BX TF 400	279566		USE	281978
279025	47	2	BX TF 400	279579		USE	279159
279037	47	2	BX TF 400	279580	47	3	BX TF 500
279042		USE	225700	279589	47	2	BX TF 400
279045		USE	276962	279630		USE	225700
279046		USE	279046	279636		USE	279790
279047		USE	228346	279637		USE	278998
279067		USE	279068	279651		USE	228141
279068	47	3	BX TF 500	279657		USE	277446
279069	47	3	BX TF 500	279662		USE	280609
279072	47	3	BX TF 500	279687		USE	277583
279073	47	3	BX TF 500	279692	82	194	TP3 TRACTOR PROT
279074	47	3	BX TF 500	279696	47	2	BX TF 400
279076		USE	278998	279701		USE	275063
279093		USE	229617	279702		USE	227321
279142		USE	225700	279707	47	3	BX TF 500
279144		USE	276781	279709		USE	227414
279150	47	2	BX TF 400	279712	47	2	BX TF 400
279159-N	69	112	PP3 PUSH PULL	279717		USE	227322
279161		USE	275286	279730		USE	279180
279162		USE	275725	279731		USE	279180
279172		USE	279321	279757		USE	279750
279176	47	2	BX TF 400	279760		USE	279988
279180-N	72	124	R6 RELAY VALVE	279761		USE	276781
279193		USE	227440	279762		USE	280609
279194		USE	275286	279766		USE	275286
279203		USE	228140	279786		USE	281587-N
279204		USE	228661	279787-N	69	112	PP3 PUSH PULL
279225		USE	279046	279790	48	11	BX TF 1000
279248	47	2	BX TF 400	279800		USE	283935
279249		USE	229617	279802	47	3	BX TF 500
279252	47	3	BX TF 500	279815		USE	275834
279260	47	2	BX TF 400	279816		USE	275834
279261	47	3	BX TF 500	279820		USE	278998
279269		USE	276781	279838	47	3	BX TF 500
279273		USE	278998	279839	47	3	BX TF 500
279282	47	2	BX TF 400	279846		USE	279046
279285		USE	228140	279857		USE	278998
279291		USE	277446	279858		USE	229000
279292		USE	227321	279859	47	3	BX TF 500
279310		USE	227403	279863		USE	227402
279311		USE	227321	279864		USE	227320
279312		USE	276961	279865	47	2	BX TF 400
279313		USE	227403	279873		USE	278998
279314		USE	227321	279886		USE	278998
279318		USE	227406	279887		USE	276911
279319		USE	227402	279890		USE	278445
279320	47	2	BX TF 400	279892		USE	280605
279321	47	2	BX TF 400	279910		USE	276635
279322		USE	279040	279919		USE	277446
279349		USE	227405	279920		USE	276911
279356	47	3	BX TF 500	279921		USE	276962
279360		USE	275317	279950-N	66	96	E5 FOOT VALVE
279362		USE	276831	279951		USE	279950
279363		USE	279040	279952-N	72	124	R6 RELAY VALVE
279364		USE	278998	279954		USE	227322
279367		USE	228140	279963		USE	226411
279381		USE	277694	279965		USE	278606
279384	47	3	BX TF 500	279966		USE	278606
279389		USE	278858	279967		USE	278606
279392		USE	229617	279968		USE	229617
279396		USE	228140	279969		USE	229617

# PRIOR AUTOMOTIVE PRODUCTS, LLC

## NUMERICAL LISTING AND INTERCHANGE

PART NO.	PAGE NO.	PICTURE REF.	DESCRIPTION OR INTERCHANGE NO. (H)-HEAD (B)-BLOCK (R)-RIGHT (L)-LEFT
279978		USE	229617
279985		USE	229617
279987		USE	279865
279988	47	2	BX TF 400
279991		USE	227407
279992		USE	227321
279993		USE	227321
279995	47	3	BX TF 500
279996		USE	279995
279997		USE	279995
280034		USE	279950
280037		USE	279750
280047		USE	229501
280050		USE	229501
280057		USE	226411
280059		USE	229617
280092		USE	277340
280093		USE	275250
280094		USE	276166
280095		USE	276961
280098		USE	227321
280218		USE	279952
280220		USE	280604
280221		USE	280603
280222		USE	280622
280233		USE	229617
280234		USE	229617
280235		USE	229617
280237		USE	280602
280238	47	3	BX TF 600
280239		USE	279176
280243	72	124	R6 RELAY VALVE
280246		USE	279750
280254		USE	276166
280257		USE	227471
280258		USE	277855
280267		USE	228141
280268		USE	228140
280277		USE	229501
280278		USE	229501
280280	47	3	BX TF 500
280282		USE	280570
280283		USE	280611
280286		USE	281751
280298	47	3	BX TF 500
280299		USE	280298
280310		USE	280622
280311		USE	276781
280327		USE	283935
280363		USE	276166
280365		USE	276962
280366		USE	229617
280367		USE	276166
280368		USE	276961
280369	47	3	BX TF 600
280373		USE	227407
280375-N	72	124	R6 RELAY VALVE
280379		USE	280498
280384		USE	279037
280385		USE	229154
280386	47	2	BX TF 400
280387		USE	229078
280388		USE	228366
280391	47	2	BX TF 400
280392	47	3	BX TF 600
280393	47	3	BX TF 600
280399		USE	275250
280422	47	3	BX TF 600
280428	47	3	BX TF 600
280429	47	3	BX TF 600
280432		USE	279037
280438		USE	227406
280445		USE	280603
280446	47	3	BX TF 600
280447	47	3	BX TF 600
280453	47	3	BX TF 500
280454	69	111	PP-2 - R&R - Exch. Only
280459		USE	279750
280462		USE	228141

PART NO.	PAGE NO.	PICTURE REF.	DESCRIPTION OR INTERCHANGE NO. (H)-HEAD (B)-BLOCK (R)-RIGHT (L)-LEFT
280469		USE	280603
280490	47	3	BX TF 500
280498	47	3	BX TF 500
280499		USE	229617
280500		USE	228140
280501	47	3	BX TF 500
280502		USE	280501
280503		USE	280501
280514	47	3	BX TF 600
280517		USE	279176
280520	47	3	BX TF 600
280522		USE	280520
280525		USE	280609
280526	47	3	BX TF 600
280538		USE	280540
280540	47	3	BX TF 600
280549		USE	280551
280551	47	3	BX TF 600
280556	47	3	BX TF 600
280565	47	3	BX TF 600
280570	47	3	BX TF 600
280573		USE	275777
280575		USE	227407
280578		USE	279750
280579		USE	280622
280589		USE	280626
280591		USE	276635
280592		USE	276635
280597		USE	279707
280600	47	3	BX TF 600
280602	47	3	BX TF 600
280603	47	3	BX TF 600
280604	47	3	BX TF 600
280605	47	3	BX TF 600
280606		USE	280605
280607	47	3	BX TF 600
280608	47	3	BX TF 600
280609	47	3	BX TF 600
280610	47	3	BX TF 600
280611	47	3	BX TF 600
280612	47	3	BX TF 600
280613		USE	280605
280618		USE	280602
280620	47	3	BX TF 600
280622	47	3	BX TF 600
280623	47	3	BX TF 600
280624	47	3	BX TF 600
280625		USE	101256
280626	47	3	BX TF 600
280626	47	3	BX TF 600
280627	47	3	BX TF 600
280628	47	3	BX TF 600
280629	47	3	BX TF 600
280630		USE	280603
280631	47	3	BX TF 600
280643		USE	280611
280644		USE	227321
280646		USE	279950
280647		USE	280604
280648		USE	280604
280651		USE	279952
280679		USE	280604
280680	47	3	BX TF 600
280706		USE	227322
280710		USE	276781
280723		USE	279159
280725		USE	280556
280727	47	2	BX TF 400
280728	47	2	BX TF 400
280729	47	2	BX TF 400
280737		USE	289347
280748		USE	280611
280755		USE	279750
280756		USE	279750
280758-N	84	212	TR3 INVERSION VA
280760		USE	278998
280761		USE	278998
280762		USE	276781
280764		USE	229617

# PRIOR AUTOMOTIVE PRODUCTS, LLC

## NUMERICAL LISTING AND INTERCHANGE

PART NO.	PAGE NO.	PICTURE REF.	DESCRIPTION OR INTERCHANGE NO. (H)-HEAD (B)-BLOCK (R)-RIGHT (L)-LEFT	PART NO.	PAGE NO.	PICTURE REF.	DESCRIPTION OR INTERCHANGE NO. (H)-HEAD (B)-BLOCK (R)-RIGHT (L)-LEFT
280765		USE	229813	281193		USE	281184
280767	47	3	BX TF 600	281194		USE	281195
280774	47	3	BX TF 600	281195	47	2	BX TF 400
280777		USE	282368	281196		USE	281195
280780		USE	280608	281199		USE	228141
280781		USE	228479	281209		USE	276831
280783		USE	280963	281214		USE	227406
280784	47	3	BX TF 600	281216		USE	280607
280797		USE	280605	281219		USE	278998
280798	47	3	BX TF 600	281220	47	2	BX TF 400
280809	85	224	DC4 NEW DBL. CK. VALV	281221		USE	227320
280809	85	224	DC4 NEW DBL. CK. VALV	281222		USE	227320
280811		USE	227321	281273		USE	275250
280817		USE	280995	281286	47	2	BX TF 400
280828		USE	227321	281287		USE	278998
280829		USE	279159	281289		USE	281560
280830		USE	279000	281315		USE	277583
280831		USE	227322	281316		USE	277583
280852		USE	280605	281318-N	84	212	INVERSION VALVE
280855		USE	280609	281338	47	2	BX TF 400
280859		USE	280628	281341	47	3	BX TF 600
280860		USE	280628	281368		USE	229001
280891		USE	280570	281388		USE	279750
280897		USE	280609	281389		USE	281440
280900		USE	280898	281401		USE	228140
280904		USE	280898	281415		USE	228141
280905		USE	282058	281418		USE	279750
280930		USE	279159	281420		USE	228141
280932		USE	279000	281423		USE	279750
280947		USE	279865	281424		USE	279750
280950		USE	280624	281430	47	3	BX TF 500
280956		USE	227407	281443		USE	228141
280958		USE	280611	281445		USE	279750
280959		USE	281481	281459-N	84	212	TR3 INVERSION VA
280963	47	3	BX TF 500	281469		USE	283585
280964		USE	280963	281470	47	3	BX TF 600
280967		USE	227322	281481	69	110	RD3
280989		USE	281042	281487		USE	277730
280995	69	110	PP1 PUSH PULL	281488		USE	277730
281004-N	66	96	E-5	281513		USE	280602
281007	47	3	BX TF 600	281527		USE	280609
281008	47	3	BX TF 600	281531	47	3	BX TF 600
281015		USE	280914	281532	47	3	BX TF 600
281016		USE	277583	281533	47	3	BX TF 600
281017		USE	227407	281540		USE	284068
281020		USE	281021	281541		USE	284068
281021	47	3	BX TF 500	281563		USE	229617
281022		USE	281021	281571		USE	279750
281024	83	200	QR1 QUICK RELEAS	281577		USE	279952
281026		USE	280914	281587	69	110	PP-1 CONTROL VAL
281042	47	3	BX TF 500	281592		USE	227402
281043		USE	281042	281593	47	3	BX TF 500
281051	47	3	BX TF 600	281596		USE	227406
281053		USE	280758	281600		USE	281718
281059		USE	227321	281601		USE	281338
281079		USE	280447	281602		USE	279037
281085		USE	229544	281603		USE	283585
281086	47	3	BX TF 500	281604		USE	281560
281088		USE	282381	281606		USE	228140
281091		USE	275286	281614		USE	279525
281094		USE	227401	281619		USE	275231
281109		USE	277000	281622	47	2	BX TF 400
281112	47	2	BX TF 400	281624		USE	281622
281118		USE	281933	281647		USE	279952
281128	47	3	BX TF 500	281661		USE	280963
281133		USE	281132	281672		USE	281865
281136		USE	279750	281677	47	3	BX TF 600
281144		USE	280386	281683		USE	281718
281145		USE	279037	281701		USE	280611
281146		USE	228366	281711		USE	281865
281149		USE	278998	281713	47	3	BX TF 600
281155		USE	281051	281715		USE	227402
281156		USE	227402	281717		USE	228140
281157	47	3	BX TF 600	281718	47	3	BX TF 500
281169		USE	227320	281719		USE	281718
281182	72	124	R6 RELAY VALVE	281726		USE	278416
281184	47	2	BX TF 400	281728		USE	278416
281191		USE	275250	281730		USE	279068
281192	47	2	BX TF 400	281731	47	3	BX TF 500

# PRIOR AUTOMOTIVE PRODUCTS, LLC

## NUMERICAL LISTING AND INTERCHANGE

PART NO.	PAGE NO.	PICTURE REF.	DESCRIPTION OR INTERCHANGE NO. (H)-HEAD (B)-BLOCK (R)-RIGHT (L)-LEFT	PART NO.	PAGE NO.	PICTURE REF.	DESCRIPTION OR INTERCHANGE NO. (H)-HEAD (B)-BLOCK (R)-RIGHT (L)-LEFT
281732	47	USE	279073	282025	47	3	BX TF 600
281733		3	BX TF 500	282038		USE	278998
281736		USE	228477	282044		USE	229078
281737		USE	229617	282049		USE	229617
281738		USE	229617	282053		USE	229617
281739		USE	229617	282076	47	3	BX TF 500
281740		USE	229617	282077		USE	279159
281741		USE	229617	282094		USE	286538
281743		USE	280540	282126		USE	227401
281751		47	3	BX TF 600		282127	USE
281761	48	11	BX TF 1000	282131		USE	227320
281762		USE	281761	282132		USE	227320
281786		USE	227401	282133		USE	283540
281787		USE	227401	282137		USE	228141
281788		USE	227322	282138		USE	227322
281789		USE	227320	282139		USE	227321
281790		USE	279865	282140		USE	227322
281825		USE	229617	282141		USE	227322
281828		USE	280605	282148		USE	228479
281841		USE	229617	282149		USE	227412
281842		USE	229617	282154		USE	280540
281843		USE	229617	282155		USE	228228
281844		USE	229617	282156		USE	228451
281845		USE	229617	282159		USE	228138
281846		USE	229617	282213		USE	228479
281847		USE	229617	282217		USE	282023
281848		USE	229617	282219		USE	227406
281849		USE	229617	282255		USE	283040
281850		USE	229617	282260		USE	228661
281851		USE	229617	282261		USE	276961
281852		USE	229617	282262	47	USE	227440
281853		USE	229617	282263		USE	282023
281854		USE	229617	282264		USE	282023
281855		USE	229617	282274		3	BX TF 600
281856		USE	279750	282275		USE	282274
281860-N	75	139	RE6 RELAY EM.	282287		USE	227471
281861		USE	281865	282289		USE	280540
281863		USE	281865	282329		USE	283040
281864		USE	281865	282330		USE	279750
281865-N		75	139	RE6 RELAY EM.		282340	USE
281866		USE	281865	282346		USE	281832
281868		USE	281865	282347		USE	280995
281869		USE	281865	282348		USE	227321
281870		USE	281865	282349		USE	227407
281875		USE	279040	282371		USE	279556
281876		USE	275286	282373		USE	279556
281879		USE	227405	282379		USE	229617
281885		USE	282010	282380		USE	282381
281901		USE	283530	282382		USE	282368
281902		47	2	BX TF 400		282382	USE
281904		USE	279750	282383		USE	276166
281909		USE	227332	282384		USE	276166
281920		USE	227410	282386		USE	276911
281921		USE	227410	282387		USE	276911
281923-N		85	220	PV2 AUTO DRAIN		282389	USE
281924	85	220	DV2 AUTO DRAIN	282394		USE	280898
281927		84	212	TR3 INVERSION VA		282395	USE
281932	48	USE	228451	282396		USE	276961
281933		11	BX TF 1000	282397		USE	276962
281940		USE	279073	282398		USE	276962
281942	70	USE	279073	282400		USE	280609
281946		114	PP5 PUSH PULL	282401		USE	280609
281947		USE	281946	282402		USE	280570
281948		USE	281946	282403		USE	280570
281959		USE	278998	282404		USE	275725
281963	47	3	BX TF 600	282405		USE	275725
281975		USE	227331	282406		USE	275725
281976	47	USE	229617	282410		USE	284760
281977		USE	279589	282411		USE	229813
281978		2	BX TF 400	282412		USE	104020
281990	47	USE	280602	282413		USE	280609
281996		2	BX TF 400	282428		USE	228364
282005		USE	227321	282430		USE	281902
282009		USE	229617	282431		USE	281902
282010	47	3	BX TF 500	282435	47	3	BX TF 600
282011	47	3	BX TF 600	282446	47	USE	275317
282012		USE	281042	282447		USE	228140
282013	47	3	BX TF 600	282452	47	3	BX TF 600
282023	47	3	BX TF 500	282454		USE	275250

# PRIOR AUTOMOTIVE PRODUCTS, LLC

## NUMERICAL LISTING AND INTERCHANGE

PART NO.	PAGE NO.	PICTURE REF.	DESCRIPTION OR INTERCHANGE NO. (H)-HEAD (B)-BLOCK (R)-RIGHT (L)-LEFT	PART NO.	PAGE NO.	PICTURE REF.	DESCRIPTION OR INTERCHANGE NO. (H)-HEAD (B)-BLOCK (R)-RIGHT (L)-LEFT
282457		USE	280369	283042		USE	283081
282460		USE	280602	283043		USE	283040
282462		USE	227405	283045	47	USE	283506
282468		USE	280602	283046		2	BX TF 400
282498		USE	280602	283047		USE	283514
282499	69	110	PP1 PUSH PULL	283048		USE	283515
282500		USE	282499	283049		USE	281286
282509		USE	282013	283051		USE	279159
282510		USE	276781	283063		USE	281338
282521	47	3	BX TF 600	283064		USE	283585
282546		USE	282013	283086		USE	283940
282554		USE	282749	283089		USE	228287
282555		USE	228346	283102		USE	228600
282564		USE	227321	283272		USE	227471
282567		USE	227407	283273		USE	284662
282569		USE	281923	283274		USE	284662
282574		USE	282499	283276		USE	275286
282575		USE	229617	283282		USE	282904
282577		USE	280603	283295		USE	281865
282578		USE	280602	283298		USE	286774
282579		USE	280602	283299		USE	292928
282580		USE	280605	283300		USE	284760
282581		USE	280602	283301		USE	284760
282582		USE	280609	283309		USE	288301
282584		USE	283827	283317	47	3	BX TF 600
282586	47	3	BX TF 500	283322		USE	279750
282587		USE	281677	283331		USE	279995
282589		USE	282586	283332		USE	279995
282590		USE	282586	283334		USE	284068
282591		USE	229525	283335		USE	284068
282596		USE	283505	283339	47	3	BX TF 500
282597		USE	283513	283340	48	11	BX TF 1000
282618		USE	282620	283345		USE	280622
282619		USE	282620	283347		USE	281923
282620	47	3	BX TF 500	283348		USE	275725
282621	47	3	BX TF 500	283350		USE	228451
282622		USE	281430	283367		USE	276166
282623		USE	228141	283368		USE	227408
282626		USE	276962	283369		USE	227408
282710		USE	278416	283371		USE	227409
282711		USE	227321	283372		USE	227409
282713		USE	227321	283387		USE	227331
282745		USE	276962	283388		USE	227331
282749	47	3	BX TF 500	283389		USE	227331
282783		USE	281286	283390		USE	227332
282785		USE	280369	283391		USE	229544
282786		USE	282620	283392		USE	227332
282787		USE	282586	283404		USE	283996
282788	47	3	BX TF 600	283405		USE	283396
282789		USE	228140	283406		USE	283996
282800		USE	284307	283409		USE	229501
282801		USE	285107	283413		USE	229859
282824		USE	228139	283424		USE	276961
282853	47	3	BX TF 600	283425		USE	283426
282875		USE	227406	283426	47	2	BX TF 400
282896		USE	227407	283427		USE	283426
282904	47	3	BX TF 500	283428		USE	283429
282928	47	3	BX TF 500	283429	47	2	BX TF 400
282937		USE	275250	283431		USE	283432
282938		USE	284037	283432	47	2	BX TF 400
282968		USE	227403	283434		USE	283435
282971		USE	280603	283435	47	2	BX TF 400
282983		USE	277544	283437		USE	283438
282984		USE	228479	283438	47	3	BX TF 500
282986		USE	228479	283440		USE	283441
283002		USE	284307	283441	47	3	BX TF 500
283004		USE	285107	283443		USE	281731
283008		USE	284687	283444		USE	281731
283012		USE	228600	283446		USE	280280
283022		USE	229617	283447		USE	280280
283025		USE	283026	283449		USE	279072
283026	47	3	BX TF 500	283450		USE	279072
283027		USE	283026	283452		USE	283453
283031		USE	228140	283453	47	3	BX TF 500
283033	72	124	R6 RELAY VALVE	283455		USE	283456
283034		USE	281865	283456	47	3	BX TF 500
283036		USE	283932	283458		USE	279068
283038		USE	277148	283459		USE	279068
283041		USE	229617	283461		USE	279069

# PRIOR AUTOMOTIVE PRODUCTS, LLC

## NUMERICAL LISTING AND INTERCHANGE

PART NO.	PAGE NO.	PICTURE REF.	DESCRIPTION OR INTERCHANGE NO. (H)-HEAD (B)-BLOCK (R)-RIGHT (L)-LEFT	PART NO.	PAGE NO.	PICTURE REF.	DESCRIPTION OR INTERCHANGE NO. (H)-HEAD (B)-BLOCK (R)-RIGHT (L)-LEFT
283462		USE	279069	283808	47	3	BX TF 600
283468		USE	281042	283809		USE	280501
283477		USE	276728	283810		USE	280501
283480		USE	282013	283812		USE	283813
283482		USE	275286	283813	47	3	BX TF 500
283483		USE	278998	283815		USE	227326
283495	47	3	BX TF 500	283816		USE	227326
283502		USE	281286	283817		USE	281924
283503		USE	228140	283820		USE	280608
283504		USE	281286	283821		USE	280608
283505	47	2	BX TF 400	283822		USE	280628
283506	47	2	BX TF 400	283823		USE	280628
283507		USE	283046	283824		USE	284307
283508		USE	229011	283825		USE	284307
283509		USE	279865	283827	69	110	PP1 PUSH PULL
283510		USE	279037	283828-N	69	110	PP1 PUSH PULL
283511		USE	281338	283829		USE	283828
283512		USE	281338	283837		USE	282570
283513	47	3	BX TF 500	283842		USE	285107
283514	47	3	BX TF 500	283843		USE	284662
283515	47	3	BX TF 500	283845		USE	282570
283516		USE	229078	283846		USE	279750
283517		USE	228366	283851		USE	281832
283525		USE	229509	283853		USE	278998
283526		USE	283530	283864		USE	286774
283527		USE	283530	283867		USE	281832
283528		USE	283533	283922		USE	283967
283530	47	2	BX TF 400	283927		USE	229501
283531		USE	283530	283931		USE	104020
283532		USE	283533	283932-N	74	137	R7 MOD. VALVE
283533	47	2	BX TF 400	283933		USE	277148
283562	47	3	BX TF 600	283934		USE	288301
283577	47	3	BX TF 500	283936		USE	229617
283578		USE	279712	283938		USE	229617
283585	47	3	BX TF 500	283940	72	124	R6 RELAY VALVE
283592		USE	227321	283950		USE	276961
283600		USE	227403	283955		USE	280570
283605		USE	284003	283962		USE	228451
283606		USE	284003	283963		USE	279707
283612		USE	228451	283965		USE	283506
283644	47	3	BX TF 500	283966		USE	283506
283646		USE	283644	283967	47	3	BX TF 500
283647		USE	283813	283969		USE	281533
283648		USE	283813	283970		USE	281533
283662	47	3	BX TF 600	283971		USE	280611
283663		USE	228479	283972		USE	280609
283664	47	3	BX TF 500	283973		USE	280610
283666		USE	283664	283974		USE	280610
283667	47	3	BX TF 500	283985		USE	229617
283669	48	11	BX TF 1000	283988		USE	283989
283686		USE	228141	283989	47	3	BX TF 600
283689		USE	283690	283991		USE	229525
283690	47	3	BX TF 500	283992		USE	229525
283692	47	3	BX TF 500	283994	47	3	BX TF 600
283706		USE	283669	283995		USE	283996
283707		USE	283669	283996	47	3	BX TF 500
283711	47	3	BX TF 500	283997		USE	283996
283714		USE	281924	283998		USE	275286
283739		USE	228165	284002		USE	284003
283745		USE	223444	284003	47	3	BX TF 500
283747		USE	284662	284005		USE	277730
283748		USE	282586	284006		USE	277730
283782		USE	278604	284008		USE	281021
283783		USE	278604	284009		USE	281021
283784		USE	277122	284011		USE	277731
283785		USE	277122	284012		USE	277731
283787		USE	282621	284014		USE	227403
283788		USE	277901	284015		USE	228269
283789		USE	277901	284016		USE	228443
283791		USE	227326	284017		USE	276974
283792		USE	227326	284018		USE	280622
283794		USE	278452	284019		USE	277694
283795		USE	278452	284020		USE	282076
283796		USE	278607	284022		USE	280556
283797		USE	278607	284023		USE	279995
283802		USE	282620	284024		USE	279995
283803		USE	282620	284025		USE	279995
283804		USE	283805	284030		3	BX TF 600
283805	47	3	BX TF 500	284031		USE	229617

# PRIOR AUTOMOTIVE PRODUCTS, LLC

## NUMERICAL LISTING AND INTERCHANGE

PART NO.	PAGE NO.	PICTURE REF.	DESCRIPTION OR INTERCHANGE NO. (H)-HEAD (B)-BLOCK (R)-RIGHT (L)-LEFT	PART NO.	PAGE NO.	PICTURE REF.	DESCRIPTION OR INTERCHANGE NO. (H)-HEAD (B)-BLOCK (R)-RIGHT (L)-LEFT
284034		USE	227332	284381		USE	275834
284037	47	3	BX TF 500	284387		USE	279159
284045		USE	229617	284402	47	3	BX TF 500
284048		USE	275286	284404		USE	228661
284055		USE	281042	284405		USE	277122
284060		USE	282499	284406		USE	277122
284067	47	USE	284068	284407		USE	277122
284068		3	BX TF 500	284408		USE	280914
284069		USE	284068	284409		USE	280605
284072		USE	283585	284410		USE	284411
284078		USE	276962	284411	47	3	BX TF 600
284082		USE	280298	284415		USE	227414
284101		USE	229000	284440		USE	227321
284103		USE	281865	284581		USE	284662
284106	47	3	BX TF 500	284662	47	3	BX TF 500
284121	47	3	BX TF 600	284663		USE	284662
284123		USE	281865	284682		USE	281042
284133		USE	280602	284688		USE	284760
284134		USE	279589	284693		USE	281042
284135		USE	279176	284696		USE	276961
284136		USE	227407	284699	47	3	BX TF 500
284138		USE	283585	284710		USE	284711
284140		USE	284160	284711	47	3	BX TF 500
284142-N	86	231	ST3 SAFETY VALVE	284714	47	3	BX TF 600
284143-N	86	231	ST3 SAFETY VALVE	284717		USE	284718
284146	84	212	TR3 INVERSION VA	284718	47	3	BX TF 500
284157		USE	278427	284719		USE	284720
284160	47	3	BX TF 500	284720	47	3	BX TF 600
284163		USE	283967	284727		USE	281481
284170		USE	279159	284728		USE	276781
284171		USE	276781	284729		USE	275250
284172		USE	227407	284730		USE	279159
284179		USE	284310	284744	70	114	PP5 PUSH PULL
284180		USE	284252	284760	66	98	E7 O-RING MNT.-NEW
284181		USE	278824	284761		USE	283585
284184		USE	284262	284762		USE	283585
284252	48	11	BX TF 1000	284763		USE	279037
284253		USE	284252	284764		USE	279037
284257		USE	284259	284765		USE	281338
284258		USE	280604	284766		USE	281338
284259	47	3	BX TF 600	284784		USE	281481
284260		USE	284310	284785		USE	276781
284262	47	3	BX TF 500	284786		USE	279159
284265		USE	276961	284788		USE	275286
284266		USE	276962	284789		USE	284790
284267		USE	227332	284790	47	3	BX TF 500
284268		USE	275777	284796		USE	227403
284269		USE	279069	284797		USE	227321
284280		USE	281865	284803		USE	284804
284281		USE	227406	284804	47	3	BX TF 600
284283		USE	227402	284815		USE	288383
284284		USE	229501	284819		USE	284160
284286		USE	281481	284820		USE	284160
284287		USE	228140	284824		USE	227320
284288		USE	281042	284834		USE	275260
284298		USE	227320	284835		USE	281481
284306		USE	284307	284836		USE	279159
284307	47	3	BX TF 600	284837		USE	284837
284309		USE	284310	284838		USE	281946
284310	47	3	BX TF 500	284855		USE	284714
284311		USE	284310	284860		USE	283828
284319		USE	282586	284864		USE	284959
284324		USE	227326	284865		USE	282586
284325		USE	227326	284866		USE	282586
284327		USE	277122	284895		USE	279159
284350		USE	284760	284900		USE	228600
284354		USE	279750	284908		USE	284699
284357		USE	276781	284909		USE	284699
284358		USE	275200	284910		USE	284718
284365		USE	229562	284911		USE	284718
284366		USE	229562	284913		USE	284714
284369		USE	284370	284914		USE	284714
284370	47	3	BX TF 600	284915		USE	284720
284371		USE	227471	284916		USE	284720
284373		USE	277583	284923		USE	276781
284374		USE	277583	284924	47	3	BX TF 600
284378		USE	280605	284933		USE	284699
284379		USE	277901	284934	47	3	BX TF 500
284380		USE	275834	284936		USE	279995

# PRIOR AUTOMOTIVE PRODUCTS, LLC

## NUMERICAL LISTING AND INTERCHANGE

PART NO.	PAGE NO.	PICTURE REF.	DESCRIPTION OR INTERCHANGE NO. (H)-HEAD (B)-BLOCK (R)-RIGHT (L)-LEFT	PART NO.	PAGE NO.	PICTURE REF.	DESCRIPTION OR INTERCHANGE NO. (H)-HEAD (B)-BLOCK (R)-RIGHT (L)-LEFT
284937		USE	279995	285570		USE	229501
284938		USE	284988	285587		USE	227320
284949		USE	278825	285590		USE	281042
284959	47	3	BX TF 500	285591		USE	276166
284968		USE	228661	285593		USE	227403
284973		USE	284974	285601	47	3	BX TF 500
284974	47	3	BX TF 500	285617	47	2	BX TF 400
284975		USE	284974	285625		USE	280609
284984		USE	228141	285628		USE	276781
284988	47	3	BX TF 500	285629		USE	276781
285097		USE	275200	285650		USE	285651
285099		USE	285107	285651	47	2	BX TF 400
285100		USE	286221	285679		USE	278998
285107	47	3	BX TF 600	285707		USE	228443
285108		USE	286221	285717		USE	277122
285128		USE	277122	285718		USE	277122
285129		USE	277122	285734		USE	281338
285130		USE	285131	285735		USE	281338
285131	47	3	BX TF 500	285736		USE	283585
285132		USE	285131	285737		USE	283585
285146		USE	284760	285745		USE	286774
285147		USE	284760	285799		USE	284662
285148-N	66	96	E 5	285800		USE	279384
285157	47	3	BX TF 500	285801		USE	279384
285158	47	3	BX TF 600	285802		USE	279384
285159		USE	227407	285805		USE	284654
285187		USE	280609	285806		USE	284959
285193	48	11	BX TF 1000	285813	47	3	BX TF 500
285200		USE	285252	285815		USE	284662
285204		USE	284662	285819		USE	276781
285205		USE	284662	285826		USE	285827
285206		USE	275725	285827	47	3	BX TF 500
285208		USE	285209	285833		USE	275250
285209	47	3	BX TF 500	285835		USE	284142
285252	47	3	BX TF 500	285837		USE	276166
285253		USE	228140	285861		USE	286528
285273		USE	229617	285862		USE	286576
285274		USE	285275	285865		USE	283515
285275	47	3	BX TF 500	285866		USE	283515
285283		USE	285275	285868		USE	286558
285284		USE	285275	285870		USE	227322
285312		USE	275700	285872		USE	286530
285323		USE	280556	285876		USE	286558
285324		USE	276781	285878		USE	286546
285331		USE	280608	285898	47	3	BX TF 500
285332		USE	284310	285899		USE	286542
285333		USE	284310	285923		USE	286576
285334		USE	279995	285924		USE	286578
285335		USE	279995	285925		USE	286536
285356		USE	275250	285927		USE	286558
285359		USE	281042	285928		USE	286578
285370		USE	280609	285929		USE	286535
285393		USE	284714	285930		USE	286526
285458		USE	284106	285932		USE	286527
285471		USE	280605	285936		USE	229617
285478		USE	284699	285937		USE	286535
285479		USE	284714	285939		USE	286532
285480		USE	279838	285940		USE	280605
285510		USE	227332	285941		USE	286537
285512		USE	280603	285942		USE	286532
285513		USE	282013	285943		USE	286535
285514		USE	283827	285947		USE	286533
285521		USE	280428	285948		USE	286529
285528		USE	223444	285949		USE	286529
285531		USE	229813	285950		USE	286541
285532		USE	228600	285951		USE	286529
285533		USE	277214	285952		USE	286527
285537		USE	277147	285953		USE	286526
285539		USE	277222	285954		USE	286526
285540	84	215	PR2 PRESS. PROTE	285955		USE	286526
285541		USE	277227	285957		USE	286527
285542		USE	278597	285959		USE	286526
285545		USE	275250	285960		USE	286560
285546		USE	277340	285961		USE	286527
285553		USE	281865	285962		USE	286527
285565		USE	278998	285963		USE	286527
285567		USE	229617	285964		USE	286527
285568		USE	229617	285965		USE	286526
285569		USE	279750	285966		USE	286526

# PRIOR AUTOMOTIVE PRODUCTS, LLC

## NUMERICAL LISTING AND INTERCHANGE

PART NO.	PAGE NO.	PICTURE REF.	DESCRIPTION OR INTERCHANGE NO. (H)-HEAD (B)-BLOCK (R)-RIGHT (L)-LEFT	PART NO.	PAGE NO.	PICTURE REF.	DESCRIPTION OR INTERCHANGE NO. (H)-HEAD (B)-BLOCK (R)-RIGHT (L)-LEFT
285967		USE	286536	286145		USE	286574
285969		USE	286535	286152		USE	229617
285970		USE	286538	286157		USE	275317
285971		USE	286538	286159		USE	282013
285972		USE	286540	286161		USE	282928
285973		USE	286538	286171-N	66	97	E6 FOOT VALVE
285974		USE	286541	286187		USE	286210
285975		USE	286579	286195	74	137	R7 MOD. VALVE
285976		USE	286539	286200		USE	286539
285977		USE	286539	286208		USE	279750
285978		USE	286539	286211		USE	281481
285980		USE	286540	286216		USE	286538
285981		USE	286540	286217		USE	286539
285982		USE	286540	286218		USE	286526
285983		USE	286540	286220		USE	286221
285984		USE	286539	286221	47	3	BX TF 600
285985		USE	286538	286286		USE	278646
285986		USE	286538	286288		USE	228346
285987		USE	286538	286289		USE	289144
285988		USE	286539	286294		USE	276166
285989		USE	286538	286296		USE	276166
285991		USE	286543	286297		USE	276961
285992		USE	286543	286357		USE	279176
285993		USE	286542	286358		USE	282011
285995		USE	286542	286360		USE	279589
286003		USE	286544	286364-N	81	187	SR1
286004		USE	286544	286365	81	187	SR1
286005		USE	286544	286370-N	72	125	R8 RELAY VALVE
286006		USE	286561	286371		USE	287260
286007		USE	286561	286377		USE	278416
286008		USE	286556	286382		USE	276961
286009		USE	286565	286383		USE	276961
286010		USE	286565	286384		USE	227407
286011		USE	286556	286387		USE	228141
286012		USE	286556	286404		USE	13250
286014		USE	286557	286406		USE	276961
286015		USE	286556	286418		USE	276962
286017		USE	286580	286439		USE	228141
286018		USE	286580	286441		USE	281042
286019		USE	286547	286442		USE	227321
286020		USE	286547	286444		USE	280609
286021		USE	286548	286455		USE	281042
286022		USE	286548	286456		USE	281042
286023		USE	286549	286457		USE	281042
286024		USE	286549	286460	84	216	PR3
286025		USE	286550	286461		USE	282928
286026		USE	286550	286462		USE	281430
286027		USE	286551	286463		USE	281430
286028		USE	286551	286464		USE	228141
286029		USE	286546	286465		USE	228141
286030		USE	286552	286467		USE	280609
286031		USE	286552	286468		USE	280609
286032		USE	286533	286471	47	3	BX TF 600
286033		USE	286533	286473		USE	282013
286034		USE	286555	286474		USE	280609
286037		USE	286554	286475		USE	280623
286038		USE	286555	286477		USE	282013
286039		USE	286555	286478		USE	282013
286040		USE	286555	286479		USE	280605
286041		USE	286554	286480		USE	284121
286042		USE	286555	286481		USE	227321
286047		USE	278998	286482		USE	282013
286066		USE	286539	286483		USE	276962
286089		USE	276781	286484		USE	276962
286092		USE	103937	286485		USE	282928
286093		USE	280758	286486		USE	229617
286094		USE	280609	286492		USE	279995
286101		USE	103936	286500-N		216	PR4 PRESS. PROTE
286103		USE	286554	286510		USE	280610
286104		USE	286563	286514		USE	286528
286105		USE	286572	286516		USE	286171
286106		USE	286571	286521		USE	286540
286119		USE	286572	286524		USE	279750
286121		USE	286571	286526	47	4	BX TF 501
286128		USE	286526	286527	47	4	BX TF 501
286131		USE	276781	286528	47	4	BX TF 501
286132		USE	286527	286529	47	4	BX TF 501
286133		USE	286527	286530	47	4	BX TF 501
286134		USE	286526	286531	47	4	BX TF 501

# PRIOR AUTOMOTIVE PRODUCTS, LLC

## NUMERICAL LISTING AND INTERCHANGE

PART NO.	PAGE NO.	PICTURE REF.	DESCRIPTION OR INTERCHANGE NO. (H)-HEAD (B)-BLOCK (R)-RIGHT (L)-LEFT	PART NO.	PAGE NO.	PICTURE REF.	DESCRIPTION OR INTERCHANGE NO. (H)-HEAD (B)-BLOCK (R)-RIGHT (L)-LEFT
286532	47	4	BX TF 501	286654		USE	284310
286533	47	4	BX TF 501	286660		USE	286542
286534		USE	286578	286662		USE	286530
286535	47	4	BX TF 501	286663		USE	286532
286536	47	4	BX TF 501	286664		USE	286533
286537		USE	286531	286665		USE	281924
286538	47	4	BX TF 501	286677		USE	229859
286539	47	4	BX TF 501	286683		USE	286535
286540	47	4	BX TF 501	286684		USE	286526
286541	47	4	BX TF 501	286687		USE	229617
286542	47	4	BX TF 501	286688		USE	229617
286543	47	4	BX TF 501	286692		USE	286527
286544	47	4	BX TF 501	286698		USE	283935
286545		USE	286544	286699		USE	286774
286546	47	4	BX TF 501	286706-N	70	115	PP 7 DASH VALVE
286547	47	4	BX TF 501	286711		USE	288383
286548	47	4	BX TF 501	286712		USE	288383
286549	47	4	BX TF 501	286713		USE	288383
286550	47	4	BX TF 501	286714		USE	288383
286551	47	4	BX TF 501	286740		USE	228510
286552	47	4	BX TF 501	286742	48	11	BX TF 1000
286554	47	4	BX TF 501	286749		USE	286826
286555	47	4	BX TF 501	286767		USE	286527
286556	47	4	BX TF 501	286771		USE	284760
286557	47	4	BX TF 501	286773		USE	286774
286558	47	4	BX TF 501	286774	66	98	E7 FOOT VALVE
286559	47	4	BX TF 501	286775		USE	286774
286560	47	4	BX TF 501	286787		USE	276793
286561	47	4	BX TF 501	286815		USE	286584
286562	47	4	BX TF 501	286818		USE	280609
286563	47	4	BX TF 501	286820		USE	276781
286564	47	4	BX TF 501	286833	47	2	BX TF 400
286565	47	4	BX TF 501	286834		USE	286364
286566	47	4	BX TF 501	286836	47	3	BX TF 600
286567	47	4	BX TF 501	286841		USE	286471
286568		USE	286542	286866	47	3	BX TF 600
286570	47	4	BX TF 501	286867		USE	286866
286571	47	4	BX TF 501	286870	47	3	BX TF 600
286572	47	4	BX TF 501	286871		USE	286870
286573		USE	286584	286872		USE	286527
286574	47	4	BX TF 501	286884		USE	286562
286576	47	4	BX TF 501	286885		USE	286562
286577		USE	286536	286888	47	3	BX TF 600
286578	47	4	BX TF 501	286889		USE	286706
286579	47	4	BX TF 501	286892		USE	287260
286580	47	4	BX TF 501	286893		USE	286364
286581	47	4	BX TF 501	286898		USE	286774
286582	47	4	BX TF 501	286899		USE	287564
286583	47	4	BX TF 501	286900		USE	287564
286584	47	4	BX TF 501	286903		USE	286500
286585	47	4	BX TF 501	286970		USE	286554
286586	47	4	BX TF 501	286974		USE	286539
286587	47	4	BX TF 501	286980		USE	280995
286589	47	4	BX TF 501	287014		USE	287015
286590	47	4	BX TF 501	287024		USE	281677
286591	47	4	BX TF 501	287034		USE	286564
286592	47	4	BX TF 501	287037	47	3	BX TF 600
286593	47	4	BX TF 501	287046	70	115	PP7 PUSH PULL
286594		USE	286584	287049		USE	286706
286595	47	4	BX TF 501	287050		USE	288301
286596	47	4	BX TF 501	287051		USE	288301
286616		USE	286543	287054		USE	276781
286617		USE	286560	287055		USE	275250
286618		USE	286555	287056		USE	279159
286619		USE	286538	287073		USE	287564
286620		USE	102697	287076		USE	286538
286622	47	4	BX TF 501	287084		USE	287260
286623		USE	286538	287085		USE	287224
286624	47	4	BX TF 501	287097		USE	286171
286625		USE	286582	287105	47	3	BX TF 600
286630		USE	286542	287108		USE	286554
286637		USE	286579	287109		USE	286530
286640		USE	286560	287114-N	72	126	R8P RELAY
286641		USE	286526	287121		USE	287195
286642		USE	286526	287122		USE	283935
286649		USE	286471	287124		USE	287564
286650		USE	286546	287125		USE	287564
286652		USE	282076	287130		USE	286706
286653		USE	284310	287132		USE	227402

# PRIOR AUTOMOTIVE PRODUCTS, LLC

## NUMERICAL LISTING AND INTERCHANGE

PART NO.	PAGE NO.	PICTURE REF.	DESCRIPTION OR INTERCHANGE NO. (H)-HEAD (B)-BLOCK (R)-RIGHT (L)-LEFT	PART NO.	PAGE NO.	PICTURE REF.	DESCRIPTION OR INTERCHANGE NO. (H)-HEAD (B)-BLOCK (R)-RIGHT (L)-LEFT
287150		USE	287564	287792		USE	286542
287155		USE	276781	287793		USE	286542
287166		USE	284760	287799		USE	229617
287176		USE	284760	287826		USE	286541
287178		USE	285683	287827		USE	286500
287180	85	224	DC4	287828	47	3	BX TF 600
287224-N	72	125	R8 RELAY VALVE	287842		USE	282076
287230		USE	287238	287844		USE	229617
287231		USE	287238	287855		USE	287411
287232		USE	283669	287856		USE	287411
287233	48	11	BX TF 1000	287887	47	3	BX TF 600
287234		USE	287240	287982		USE	289545
287235		USE	287238	287986		USE	287238
287236		USE	287240	287987		USE	276781
287237		USE	229077	287988		USE	283662
287238-N	70	116	PP8 RELAY	287989		USE	283662
287240	70	116	PP8 RELAY	288005		USE	287417
287251		USE	286706	288006		USE	282499
287252		USE	286364	288007		USE	286706
287254		USE	287411	288008		USE	287418
287255		USE	286171	288035		USE	286570
287256		USE	287418	288050		USE	101487
287257		USE	287417	288051		USE	284142
287259		USE	287046	288052		USE	229617
287260-N	72	125	R8 RELAY VALVE	288055		USE	279000
287261		USE	287334	288056		USE	288237
287276		USE	289148	288058		USE	229617
287277		USE	287260	288060		USE	286527
287278		USE	286364	288061		USE	286527
287280		USE	286706	288062		USE	286526
287282		USE	286706	288063		USE	286364
287291		USE	288383	288071		USE	286584
287303		USE	286526	288080		USE	228600
287315		USE	228287	288087		USE	286565
287325		USE	282499	288088		USE	286565
287347		USE	287260	288095		USE	286774
287375		USE	287376	288221		USE	287260
287376-N	81	188	SR2 SPRING BRAKE	288239		USE	286706
287377		USE	227407	288240		USE	287046
287378		USE	227407	288241-N	70	115	PP-7
287379		USE	276781	288242-N	70	115	PP7
287395		USE	286744	288251	83	200	QR1 VALVE
287396		USE	286774	288253		USE	282472
287405		USE	229077	288260		USE	280570
287407		USE	287411	288267	66	98	E7
287408		USE	287411	288294		USE	286533
287411	66	98	E7 FOOT VALVE	288295		USE	288301
287417-N	69	110	PP1 PUSH PULL	288297		USE	289541
287418	70	116	PP8 PUSH PULL	288302		USE	286589
287421		USE	287260	288313		USE	289541
287429		USE	278998	288320		USE	286541
287440		USE	286774	288323-N	84	216	PR4 PRESS. PROTE
287483		USE	286526	288369		USE	287260
287501		USE	286774	288374		USE	229617
287515		USE	283828	288383-N	66	98	E7
287520		USE	229505	288386		USE	288299
287564	66	98	E7 FOOT VALVE	288418	47	2	BX TF 400
287567		USE	287238	288429		USE	276781
287599		USE	284790	288430		USE	276781
287600		USE	287417	288481	47	3	BX TF 600
287605		USE	286546	288497-N	81	188	SR 2 VALVE
287609		USE	286566	288513		USE	288383
287610		USE	286566	288527		USE	287564
287620		USE	283828	288577		USE	276781
287626		USE	280809	288578	48	11	BX TF 1000
287627		USE	280809	288586	84	212	TR3 INVERSION VA
287629		USE	286528	288605-N	82	196	TP5 TRACTOR PROT
287631		USE	286567	288643		USE	288644
287632		USE	286567	288644	70	115	PP7
287633		USE	286543	288650		USE	287238
287634		USE	286543	288658		USE	286528
287635		USE	281262	288668		USE	288605
287636	48	11	BX TF 1000	288674		USE	286543
287637	69	110	PP1 PUSH PULL	288684		USE	284066
287641		USE	286542	288686		USE	284714
287693		USE	288267	288693		USE	286586
287738		USE	287411	288700		USE	289545
287768		USE	282013	288707		USE	229617
287769		USE	282013	288710	47	3	BX TF 600

# PRIOR AUTOMOTIVE PRODUCTS, LLC

## NUMERICAL LISTING AND INTERCHANGE

PART NO.	PAGE NO.	PICTURE REF.	DESCRIPTION OR INTERCHANGE NO. (H)-HEAD (B)-BLOCK (R)-RIGHT (L)-LEFT	PART NO.	PAGE NO.	PICTURE REF.	DESCRIPTION OR INTERCHANGE NO. (H)-HEAD (B)-BLOCK (R)-RIGHT (L)-LEFT
288714	47	3	BX TF 600	289301		USE	289339
288715	47	3	BX TF 600	289310		USE	65075
288721	70	115	PP-7	289318		USE	289342
288722		USE	288299	289321		USE	289925
288734	47	3	BX TF 500	289323		USE	289925
288746		USE	279159	289327		USE	289342
288755		USE	287260	289328		USE	289925
288773		USE	276781	289330		USE	289344
288776		USE	280369	289331		USE	289342
288777		USE	288383	289333		USE	106792
288779		USE	286774	289336	47	5	BX TF 700
288782		USE	288299	289337		USE	289336
288784		USE	227407	289339	47	5	BX TF 700
288842		USE	286581	289340	47	5	BX TF 700
288860		USE	276781	289341		USE	289915
288861		USE	288383	289342	47	5	BX TF 700
288862		USE	288383	289343		USE	289925
288863		USE	288383	289344	47	5	BX TF 700
288890	47	3	BX TF 500	289346		USE	289339
288900		USE	287224	289347	47	5	BX TF 700
288906		USE	286546	289348	47	5	BX TF 700
288930	48	11	BX TF 1000	289349	47	5	BX TF 700
288942		USE	286582	289350	47	5	BX TF 700
288948		USE	288383	289351		USE	289925
288951		USE	286546	289388		USE	289400
288952		USE	282076	289395		USE	287260
288974		USE	286526	289400	47	2	BX TF 400
288975		USE	280609	289401		USE	275317
288982		USE	286544	289402		USE	275317
288988		USE	229617	289403		USE	227406
288989	48	11	BX TF 1000	289404		USE	279150
289003		USE	289545	289405		USE	227407
289003		USE	289545	289406		USE	279150
289015		USE	286591	289407		USE	227406
289015		USE	286591	289408		USE	227407
289034		USE	275175	289409		USE	289823
289042		USE	229813	289410		USE	227407
289043		USE	286584	289411		USE	279150
289060		USE	101786	289412		USE	227407
289090		USE	287238	289413		USE	276911
289097		USE	286535	289414		USE	275317
289120		USE	286706	289415		USE	281220
289121		USE	286585	289416		USE	227407
289123		USE	281677	289417		USE	289823
289144-N	83	205	LQ4 FRONT AXLE R	289418		USE	283426
289145		USE	289148	289419		USE	278416
289147		USE	289144	289420		USE	227406
289148-N	83	205	LQ4 FRONT AXLE R	289421	47	2	BX TF 400
289149		USE	289144	289422		USE	283429
289150		USE	289144	289423		USE	278416
289154	47	2	BX TF 400	289424		USE	275317
289158	47	2	BX TF 400	289425		USE	227406
289159		USE	289336	289426		USE	278416
289172	47	3	BX TF 600	289427		USE	289611
289182-N	83	202	QR1C QUICK RELEA	289428		USE	275317
289184		USE	229154	289429		USE	279150
289238		USE	289350	289430		USE	283426
289246		USE	289348	289431		USE	279150
289251		USE	289340	289432		USE	278416
289253		USE	288605	289433		USE	279150
289256		USE	229617	289434		USE	289820
289257		USE	289347	289435		USE	289610
289258		USE	289349	289436		USE	279150
289259		USE	287240	289437		USE	276911
289260		USE	287240	289443		USE	279150
289261		USE	286593	289477	69	112	PP-3
289262		USE	289925	289487		USE	284143
289263		USE	289915	289490		USE	288383
289264		USE	289790	289495		USE	280609
289265		USE	289925	289496		USE	281220
289267		USE	289941	289498		USE	275317
289276		USE	289342	289512	69	112	PP-3
289281		USE	289925	289513		USE	283435
289282		USE	106793	289521		USE	229617
289288	84	212	TR3 INVERSION VA	289522		USE	229617
289289		USE	289941	289525		USE	229859
289290		USE	106791	289541		USE	289541
289292		USE	289789	289543		USE	280995
289300		USE	289339	289545	47	2	BX TF 400

# PRIOR AUTOMOTIVE PRODUCTS, LLC

## NUMERICAL LISTING AND INTERCHANGE

PART NO.	PAGE NO.	PICTURE REF.	DESCRIPTION OR INTERCHANGE NO. (H)-HEAD (B)-BLOCK (R)-RIGHT (L)-LEFT	PART NO.	PAGE NO.	PICTURE REF.	DESCRIPTION OR INTERCHANGE NO. (H)-HEAD (B)-BLOCK (R)-RIGHT (L)-LEFT
289548		USE	281677	3018532	51	22	Cummins/Holset
289593		USE	227407	3018534		USE	3049186
289597		USE	286587	3018541		USE	3018542
289607		USE	276781	3018542		USE	3018527
289610	47	2	BX TF 400	3018543		USE	3049186
289611	47	2	BX TF 400	3018544		USE	3049186
289620		USE	286590	3018545		USE	3049186
289648		USE	281677	3018550	56	57	Cummins/Holset
289682		USE	282499	3018551		USE	3049186
289687		USE	289688	3018553		USE	3049186
289688	47	2	BX TF 400	3018555		USE	3049186
289714-N	83	202	QR1C QUICK RELEA	3024365		USE	3049186
289716		USE	289925	3025831	56	54	Cummins/Holset
289743		USE	289744	3025832	56	55	Cummins 2 Cyl.
289744	47	5	BX TF 700	3025833	56	56	Cummins/Holset
289751		USE	286592	3046440		USE	3049186
289753		USE	280609	3047440	51	25	Cummins/Holset
289786		USE	289941	3048672	58	64	Cummins/Holset
289789	47	5	BX TF 700	3048673	56	57	Cummins/Holset
289790	47	5	BX TF 700	3048675	57	58	Cummins/Holset
289792		USE	281677	3048677	57	59	Cummins/Holset
289793	47	3	BX TF 600	3048680	57	60	Cummins/Holset
289795		USE	287260	3049186	51	23	Cummins/Holset
289799		USE	276781	3052776	51	26	Cummins/Holset
289802		USE	283669	3056615	57	61	Cummins/Holset
289807		USE	286538	3558000	52	30	Cummins/Holset
289811		USE	289925	3558005	55	46	Cummins/Holset
289814		USE	283426	3558006	55	47	Cummins/Holset
289816		USE	278416	3558010	57	62	Cummins/Holset
289817		USE	283429	3558013	51	25	Cummins/Holset
289818		USE	227407	3558015	51	23	Cummins/Holset
289819		USE	227406	3558016	51	25	Cummins/Holset
289820	47	2	BX TF 400	3558019	58	65	Cummins/Holset
289821		USE	289820	3558020	51	23	Cummins/Holset
289823	47	2	BX TF 400	3558021	55	46	Cummins/Holset
289824		USE	289823	3558022	55	47	Cummins/Holset
289825		USE	227414	3558023	55	46	Cummins/Holset
289838		USE	289789	3558027	57	63	Cummins/Holset
289847		USE	289924	3558029	52	30	Cummins/Holset
289863		USE	289941	3558035	52	29	Cummins/Holset
289864		USE	289941	3558036	58	66	Cummins/Holset
289865		USE	289350	3558040		USE	NT7523
289866		USE	289925	3558041	58	67	Cummins/Holset
289867		USE	289969	3558042	52	31	Cummins/Holset
289868		USE	289964	3558043	52	31	Cummins/Holset
289877		USE	275317	3558044	51	25	Cummins/Holset
289907		USE	289907	3558045	51	23	Cummins/Holset
289914		USE	282058	3558045	51	23	Cummins/Holset
289915	47	5	BX TF 700	3558046	51	26	Cummins/Holset
289924	47	5	BX TF 700	3558047	51	26	Cummins/Holset
289925	47	5	BX TF 700	3558049	53	39	Cummins/Holset
289926		USE	289925	3558050	53	39	Cummins/Holset
289936		USE	289350	3558051	55	48	Cummins/Holset
289937		USE	289941	3558052	55	48	Cummins/Holset
289939		USE	289925	3558052	55	48	Cummins/Holset
289940		USE	289941	3558068	52	32	Cummins/Holset
289941	47	5	BX TF 700	3558068	52	32	Cummins/Holset
289954		USE	276569	3558072	52	28	Cummins/Holset
289964	47	5	BX TF 700	3558074	52	28	Cummins/Holset
289965		USE	289789	3558075	52	33	Cummins/Holset
289966		USE	289339	3558076	52	33	Cummins/Holset
289969	47	5	BX TF 700	3558077	52	32	Cummins/Holset
289994		USE	289789	3558080	51	27	Cummins/Holset
289997		USE	288644	3558081	54	45	Cummins/Holset
299026	47	2	BX TF 400	3558082	53	37	Cummins/Holset
299045		USE	286742	3558092	53	36	Cummins/Holset
299112	47	3	BX TF 500	3558093	53	36	Cummins/Holset
299191		USE	282928	3558097	54	41	Cummins/Holset
299476		USE	289793	3558098	54	41	Cummins/Holset
1189499		no pic	BX IW250R Compressor	3558102	54	45	Cummins/Holset
2500006	47	6	Duraflo 596 Comp	3558105	54	43	Cummins/Holset
3005840		USE	3018527	3558107	52	32	Cummins/Holset
3010879		USE	3018527	3558108	52	33	Cummins/Holset
3015034		USE	3018527	3558109	52	33	Cummins/Holset
3015630		USE	3049186	3558110	52	32	Cummins/Holset
3016082		USE	3018527	3558113	55	49	Cummins/Holset
3018527	51	22	Cummins/Holset	3558115	55	50	Cummins/Holset
3018530		USE	3018527	3558116	55	50	Cummins/Holset
3018531		USE	3018527	3558131	52	28	Cummins/Holset

# PRIOR AUTOMOTIVE PRODUCTS, LLC

## NUMERICAL LISTING AND INTERCHANGE

PART NO.	PAGE NO.	PICTURE REF.	DESCRIPTION OR INTERCHANGE NO. (H)-HEAD (B)-BLOCK (R)-RIGHT (L)-LEFT	PART NO.	PAGE NO.	PICTURE REF.	DESCRIPTION OR INTERCHANGE NO. (H)-HEAD (B)-BLOCK (R)-RIGHT (L)-LEFT
3558139	54	43	Cummins/Holset	5001711		USE	107507
3558142	55	51	Cummins/Holset	5001740		USE	65612
3558143	55	51	Cummins/Holset	5001743		USE	65693
3558144	53	34	Cummins/Holset	5001749		USE	104473
3558145	53	34	Cummins/Holset	5001773		USE	109139
3558146	53	35	Cummins/Holset	5001774		USE	109139
3558147	53	35	Cummins/Holset	5001788		USE	109863
3558163		USE	9111535200	5001789		USE	109863
3558164	53	38	Cummins/Holset	5001869		USE	5001911
3558167		USE	3558208	5001870		USE	5001912
3558182	53	38	Cummins/Holset	5001904		USE	5001940
3558186	56	52	Cummins/Holset	5001911	48	7	BX TF 550
3558188	56	53	Cummins/Holset	5001912	48	8	BX TF 750
3558189	56	52	Cummins/Holset	5001938		USE	109809
3558199	54	44	Cummins/Holset	5001939		USE	109659
3558206		USE	3558208	5001940	48	7	BX TF 550
3558208	54	40	Cummins/Holset	5001942		USE	109147
3558209	54	40	Cummins/Holset	5002002		USE	108066
3558211	54	42	Cummins/Holset	5002032		USE	109139
3558212	54	42	Cummins/Holset	5002033		USE	109863
4059825		USE	9111535200	5002082		USE	109142
5000104		USE	65691	5002177	48	7	BX TF 550
5000130		USE	107514	5002178	48	7	BX TF 550
5000145		USE	65691	5002222		USE	107511
5000154		USE	65612	5002223		USE	107510
5000155		USE	65612	5002230		USE	65691
5000156		USE	65612	5002231		USE	65694
5000190		USE	107622	5002328		USE	5002548
5000191		USE	107623	5002381		USE	286171
5000192		USE	107622	5002389		USE	5001940
5000193		USE	107623	5002393	48	12	BX TF 1400
5000213		USE	65612	5002548	48	8	BX TF 750
5000214		USE	65612	5002640		USE	107511
5000291		USE	5011016	5002641		USE	107510
5000292		USE	5011016	5002652		USE	109863
5000351		USE	800089	5002713		USE	109863
5000433		USE	109079	5002747		USE	65691
5000445		USE	800042	5002748		USE	800042
5000446		USE	800043	5002814		USE	107866
5000447		USE	800042	5002826		USE	109142
5000448		USE	800043	5002839		USE	5001940
5000559		USE	107981	5002864		USE	107511
5000587		USE	65691	5002865		USE	107511
5000594		USE	107514	5002867		USE	107510
5000600		USE	5000602	5002868		USE	107510
5000601		USE	5000603	5002900		USE	65612
5000602	48	7	BX TF 550	5002972		USE	5002973
5000603	48	8	BX TF 750	5002973	48	8	TF 750
5000641		USE	107508	5002983		USE	109142
5000689		USE	229859	5002984		USE	109139
5000709		USE	800067	5003072		USE	5003254
5000794		USE	65612	5003150		USE	5003153
5000799		USE	109552	5003153	48	7	BX TF 550
5000832		USE	5011016	5003179		USE	5003302
5000848		USE	5002177	5003227		USE	5003424
5000859		USE	5011016	5003228		USE	109139
5000940		USE	286538	5003229		USE	109139
5000985		USE	800089	5003230		USE	109139
5001085		USE	5015615	5003231		USE	109142
5001170		USE	65691	5003232		USE	109142
5001171		USE	65694	5003233		USE	109142
5001172		USE	800042	5003234		USE	109863
5001173		USE	800043	5003235		USE	109863
5001483		USE	800042	5003236		USE	109863
5001484		USE	800043	5003254	48	7	BX TF 550
5001509		USE	800089	5003264		USE	107506
5001522		USE	109139	5003265		USE	107507
5001523		USE	109139	5003294		USE	65613
5001533		USE	109142	5003302	48	7	BX TF 550
5001534		USE	109142	5003323		USE	5003302
5001614		USE	109425	5003324		USE	5003302
5001615		USE	109425	5003553		USE	5003563
5001616		USE	109426	5003563	48	7	BX TF 550
5001617		USE	109426	5003645		USE	109251
5001660		USE	5002548	5003646		USE	109251
5001662		USE	5002548	5003648		USE	109287
5001708		USE	5002178	5003649		USE	109287
5001708		USE	5002178	5003728		USE	108866
5001710		USE	107506	5003729		USE	108869

# PRIOR AUTOMOTIVE PRODUCTS, LLC

## NUMERICAL LISTING AND INTERCHANGE

PART NO.	PAGE NO.	PICTURE REF.	DESCRIPTION OR INTERCHANGE NO. (H)-HEAD (B)-BLOCK (R)-RIGHT (L)-LEFT	PART NO.	PAGE NO.	PICTURE REF.	DESCRIPTION OR INTERCHANGE NO. (H)-HEAD (B)-BLOCK (R)-RIGHT (L)-LEFT
5003762		USE	5011016	5005934		USE	109426
5003834		USE	5003852	5006234		USE	800618
5003850		USE	5004118	5006292		USE	800632-N
5003852	48	8	BX TF 750	5006352		USE	5006353
5003888		USE	5011016	5006353	47	6	Duraflo 596 Comp
5003889		USE	5011016	5006354		USE	5006353
5003976		USE	65612	5006355		USE	5006353
5004050		USE	5003424	5006461		USE	5003850
5004082		USE	109425	5006567		USE	5006570
5004083		USE	109426	5006568		USE	5006570
5004088		USE	5004124	5006569		USE	5006570
5004112		USE	5004118	5006570	47	6	Duraflo 596 Comp
5004113		USE	5004118	5006591		USE	65612
5004118	48	8	BX TF 750	5006634		USE	65612
5004124	48	7	BX TF 550	5006639		USE	65691
5004187		USE	109426	5006700		USE	65691
5004188		USE	109425	5006716		USE	109552
5004338		USE	5004342-H or S	5006820		USE	109603
5004341-H	59	70	AD-9 12V Prg Vlv-Hrd	5006821		USE	109604
5004341-S	59	70	AD-9 12V Prg Vlv-Sft	5006822		USE	107509
5004416		USE	5005875	5006823		USE	107508
5004417		USE	5005875	5006824		USE	109251
5004611		USE	109088	5006832		USE	5003852
5004612		USE	109111	5006848		USE	65612
5004613		USE	BX TF 550	5006879		USE	65612
5004614		USE	109111	5006887		USE	5008249
5004711		USE	5004880	5007076		USE	5007085
5004713		USE	5007085	5007077		USE	5007085
5004717		USE	5007099	5007085	47	6	Duraflo 596 Comp
5004880	48	7	BX TF 550	5007095		USE	5007099
5004882		USE	5004880	5007096		USE	5007099
5004883		USE	5004880	5007099	47	6	Duraflo 596 Comp
5004950		USE	5005272	5007252		USE	65613
5005028		USE	107514	5007270		USE	65612
5005028		USE	107514	5007361		USE	5008249
5005037-N	59	71	AD-9 Purge Vlv. Kit	5007362		USE	5008249
5005268		USE	65612	5007363	48	7	BX TF 550
5005270		USE	65612	5007465		USE	5007465
5005272	48	7	BX TF 550	5007466		USE	5007465
5005349		USE	109659	5007467		USE	5007465
5005387		USE	65613	5007468		USE	109142
5005412		USE	109552	5007469		USE	109142
5005413		USE	109552	5007471		USE	109142
5005414		USE	5004118	5007911		USE	5009283
5005415		USE	109287	5008081		USE	65691
5005416		USE	109287	5008127		USE	5001940
5005417		USE	109287	5008248		USE	5008249
5005418		USE	109604	5008249	48	7	BX TF 550
5005419		USE	109863	5008250		USE	5008249
5005420		USE	107508	5008251		USE	5008249
5005421		USE	109142	5008303		USE	5005875
5005422		USE	109142	5008332X		USE	5007593
5005438		USE	109659	5008554		USE	5009205
5005459		USE	5004118	5008609		USE	109425
5005466		USE	109287	5008610		USE	109426
5005473		USE	109604	5008871X		USE	5005921
5005478		USE	109863	5009111		USE	65694
5005479		USE	109863	5009205	48	7	BX TF 550
5005483		USE	107508	5009233		USE	5009232
5005491		USE	109142	5009283	48	7	BX TF 550
5005492		USE	109142	5009328		USE	5015314
5005496		USE	109142	5009329		USE	5015314
5005500		USE	5005503	5009330		USE	5015314
5005502		USE	5005503	5009347X		USE	5008925
5005503	48	7	BX TF 550	5009391		USE	5014488
5005556		USE	800576	5009392		USE	5014488
5005567		USE	800577	5009393		USE	5014489
5005606		USE	5005790	5009394		USE	5014489
5005697		USE	65612	5009413		USE	65613
5005702		USE	65613	5009483X		USE	5009232
5005770		USE	5005790	5009746		USE	107813
5005790	48	7	BX TF 550	5009770	48	8	TF-750
5005791		USE	5005790	5009792		USE	5013157
5005870	47	6	Duraflo 596 Comp	5009817		USE	65612
5005875	47	6	Duraflo 596 Comp	5010104X		USE	5008296
5005893-N	59	72	AD-9 Purge Vlv. Kit	5011075X		USE	5011074
5005920		USE	5005875	5010133X		USE	5010134
5005932		USE	5000603	5010134	62	81	AD-IS Dryer - NEW
5005933		USE	109425	5010211X		USE	5010212

# PRIOR AUTOMOTIVE PRODUCTS, LLC

## NUMERICAL LISTING AND INTERCHANGE

PART NO.	PAGE NO.	PICTURE REF.	DESCRIPTION OR INTERCHANGE NO. (H)-HEAD (B)-BLOCK (R)-RIGHT (L)-LEFT	PART NO.	PAGE NO.	PICTURE REF.	DESCRIPTION OR INTERCHANGE NO. (H)-HEAD (B)-BLOCK (R)-RIGHT (L)-LEFT
5010213		USE	5010212	800159		USE	5002548
5010279		USE	109552	800178		USE	5001911
5010684		USE	5010900	800180		USE	5001940
5010695		USE	5010694	800183		USE	5001940
5010696X		USE	5010694	800222		USE	5002177
5010803	48	9	BA921 Compressor	800223		USE	5002178
5010806	48	9	BA921 Compressor	800241		USE	5002548
5010824	48	9	BA921 Compressor	800245		USE	107511
5010924X		USE	5010900	800246		USE	107510
5011016	48	7	BX TF 550	800256		USE	109863
5011086		USE	5005875	800260	72	122	Park Control PP-DC
5011427	48	9	BA921 Compressor	800273		USE	107511
5011471		USE	5012895	800274		USE	107510
5011616		USE	5013695	800290		USE	5002973
5011624		USE	5013058	800291		USE	109142
5011625		USE	5013059	800292		USE	109139
5012532	48	9	BA921 Compressor	800309	72	122	Park Control PP-DC
5012533	48	9	BA921 Compressor	800315		USE	5003153
5012663	48	8	BX TF 750	800324		USE	5003254
5012664	48	8	BX TF 750	800328		USE	5003302
5012665		USE	109653	800341		USE	5003563
5012666		USE	109382	800350-150-N	86	231	ST4 Safety Valve
5012744	48	9	BA921 Compressor	800350-175-N	86	231	ST4 Safety Valve
5012774	48	9	BA921 Compressor	800350-200-N	86	231	ST4 Safety Valve
5012794		USE	5018485	800471-N	73	131	R-12DC
5012893		USE	5012895	800354		USE	108866
5012894		USE	5012895	800355		USE	108869
5012895	48	10	BA922 Compressor	800362		USE	5003852
5013058	48	10	BA922 Compressor	800364		USE	5011016
5013059	48	10	BA922 Compressor	800381	73	132	R-12DC
5013063		USE	5013058	800383		USE	5003424
5013064		USE	5013058	800385		USE	5004118
5013070		USE	5013059	800386		USE	5004124
5013071		USE	5013059	800394		USE	109426
5013156		USE	5013157	800395		USE	109425
5013157	48	10	BX TF 750	800404	61	80A	AD-IP Purge Vlv. Old Style
5013262		USE	5012895	800405		USE	5004341-H or S
5013693		USE	5013695	800468		USE	109088
5013694		USE	5013695	800469		USE	109111
5013695	48	10	BA922 Compressor	800477	74	133	R-12DC
5013830	48	7	BX TF 550	800484	73	129	R-12
5014143		USE	5014144	800505		USE	5004880
5014144	48	7	BX TF 550	800516		USE	065157-N
5014145		USE	5014146	800551		USE	65612
5014146	48	8	BX TF 750	800552		USE	5005272
5014401		USE	5014428	800572		USE	5005503
5014427	48	9	BA921 Compressor	800594		USE	5005790
5014428	48	9	BA921 Compressor	800595		USE	5005875
5014484		USE	5014488	800629-N	67	99	E-8P
5014485		USE	5014489	800632-N	67	101	E-10P
5014488	48	8	BX TF 550	800635		USE	5006353
5014489	48	8	BX TF 750	800658		USE	5006570
5015314	48	7	BX TF 550	800696		USE	5007085
5015318		USE	5015314	800703		USE	5007099
5015615	48	7	BX TF 550	800718		USE	5008249
5016044		USE	5016389	800724		USE	5007465
5016078		USE	108779	800725		USE	109142
5016380		USE	5016389	800816		USE	5001940
5016381		USE	5016389	800838		USE	5007593
5016389	48	10	BA922 Compressor	800857		USE	65613
5016612		USE	5018485	800887		USE	65691
5016799		USE	5018485	800959		USE	5005921
5016940	48	7	BX TF 550	800972		USE	65694
5018064	48	9	BA921 Compressor	800973		USE	800042
5018275	48	7	BX TF 550	800974		USE	800043
5018485	48	9	BA921 Compressor	801043		USE	5009205
5018652	48	9	BA921 Compressor	801045		USE	5009232
5018653	48	9	BA921 Compressor	801072		USE	5009283
5018655	48	9	BA921 Compressor	801085		USE	5008925
6997312V	85	225	Fuel Solenoid	801087		USE	5015314
6997324V	85	225	Fuel Solenoid	801098		USE	5014488
800017		USE	107623	801099		USE	5014489
800018		USE	107622	801100		USE	5009232
800021		USE	65612	801145		USE	5008296
800034	72	122	Park Control PP-DC	801147		USE	5010134
800060		USE	5000602	801149		USE	5009770
800061		USE	5000603	801164		USE	5010212
800074		USE	5011016	801264		USE	5010900
800142	72	122	Park Control PP-DC	801266		USE	5010694

# PRIOR AUTOMOTIVE PRODUCTS, LLC

## NUMERICAL LISTING AND INTERCHANGE

PART NO.	PAGE NO.	PICTURE REF.	DESCRIPTION OR INTERCHANGE NO. (H)-HEAD (B)-BLOCK (R)-RIGHT (L)-LEFT	PART NO.	PAGE NO.	PICTURE REF.	DESCRIPTION OR INTERCHANGE NO. (H)-HEAD (B)-BLOCK (R)-RIGHT (L)-LEFT
801301		USE	5010900	9111545200	49	13	Wabco-250 75MM
801324		USE	5011041	9115051540	49	15	Wabco-636 Twin 85MM
801330		USE	5011074	9115150050	49	15	Wabco-636 Twin 85MM
801463		USE	5012532	9115150070	49	15	Wabco-636 Twin 85MM
801484		USE	5012663	9115150077	494	15	Wabco-636 Twin 85MM
801485		USE	5012664	9115150200	49	15	Wabco-636 Twin 85MM
801506		USE	109653	9115150210	49	15	Wabco-636 Twin 85MM
801507		USE	109382	9115159370	49	15	Wabco-636 Twin 85MM
801535		USE	5012895	9115160107	49	15	Wabco-636 Twin 85MM
801594		USE	5013058	9115169220	49	15	Wabco-636 Twin 85MM
801595		USE	5013059	9121420010	49	14	Wabco-318 85MM
801598		USE	5013157	9125181089	49	15	Wabco-636 Twin 85MM
801732		USE	5013695	9125420020	49	15	Wabco-636 Twin 85MM
801795		USE	5014144	9125420070	49	15	Wabco-636 Twin 85MM
801827		USE	5014488	90054007-N	87	237	Neway Leveling Valve
801828		USE	5014489	99600-N	87	235	Sealco Dash Valve
801971		USE	5015314				
802158		USE	5016389				
802767		USE	5012794				
802767		USE	5018485				
85000064		no pic	Knorr LP49 Series 88MM				
4111450040	49	13	Wabco-250 75MM				
4111450050	49	13	Wabco-250 75MM				
4123520010	49	14	Wabco-318 85MM				
4123520020	49	14	WABCO 318 85mm				
4123520050	49	14	WABCO 318 85mm				
4123520057	49	14	WABCO 318 85mm				
4123520140	49	14	WABCO 318 85mm				
4127040080	49	15	WABCO Twin				
4127040087		USE	4127040080				
9111454130	49	13	Wabco-250 75MM				
9111515937	49	15	Wabco-636 Twin 85MM				
9111530030	49	14	Wabco-318 85MM				
9111530040	49	14	Wabco-318 85MM				
9111530100	49	14	Wabco-318 85MM				
9111530110	49	14	Wabco-318 85MM				
9111530120	49	14	Wabco-318 85MM				
9111530140	49	14	Wabco-318 85MM				
9111530150	49	14	Wabco-318 85MM				
9111530190	49	14	Wabco-318 85MM				
9111530200		USE	9111535300				
9111530200	49	14	Wabco-318 85MM				
9111530227	49	14	Wabco-318 85MM				
9111530270	49	14	Wabco-318 85MM				
9111530557		USE	9111535400				
9111535100	49	14	Wabco-318 85MM				
9111535120	49	14	Wabco-318 85MM				
9111535130	49	14	Wabco-318 85MM				
9111535200	49	14	Wabco-318 85MM				
9111535207		USE	9111535200				
9111535240	49	14	Wabco-318 85MM				
9111535250	49	14	Wabco-318 85MM				
9111535300	49	14	Wabco-318 85MM				
9111535320	49	14	Wabco-318 85MM				
9111535330	49	14	Wabco-318 85MM				
9111535340	49	14	Wabco-318 85MM				
9111535350	49	14	Wabco-318 85MM				
9111535360	49	14	Wabco-318 85MM				
9111535370	49	14	Wabco-318 85MM				
9111535380	49	14	Wabco-318 85MM				
9111535400	49	14	Wabco-318 85MM				
9111535410	49	14	Wabco-318 85MM				
9111535430	49	14	Wabco-318 85MM				
9111535460	49	14	Wabco-318 85MM				
9111535490	49	14	Wabco-318 85MM				
9111536070	49	14	Wabco-318 85MM				
9111536080	49	14	Wabco-318 85MM				
9111539380	49	14	Wabco-318 85MM				
9111539387		USE	9111535300				
9111540010	49	13	Wabco-250 75MM				
9111545000	49	13	Wabco-250 75MM				
9111545020	49	13	Wabco-250 75MM				
9111545030	49	13	Wabco-250 75MM				
9111545090	49	13	Wabco-250 75MM				
9111545100	49	13	Wabco-250 75MM				
9111545110	49	13	Wabco-250 75MM				
9111545130	49	13	Wabco-250 75MM				
9111545150	49	13	Wabco-250 75MM				
9111545157	49	13	Wabco-250 75MM				

CATERPILLAR PART NO.	PRIOR PART NO.				
OR2899	286584	1316680	109863	4P2419	107981
OR2902	103274	1329813	109861	4P3956	107981
OR2904	283996	1329814	109863	4P6041	108990
OR3391	107981	1399009	109142	5M8271	277730
OR3404	109251	1434924	109552	5S9640	N5060D
OR3405	109287	1439185	109861	5Z898	284310
OR3410	109603	1439186	109142	5Z918	279995
OR3411	109604	1442906	109251	6H1629	N5060D
OR3659	107509	1442907	109287	6I1670	107981
OR3845	109861	1444412	5003254	6N7582	286584
OR4115	107508	1450840	5003302	7E08541	107919
OR4382	109603	1494915	109451	7E2303	107526
OR4383	109604	1569365	5004880	7E3879	107526
OR4740	109863	1609845	109659	7E7619	107508
OR8252	109451	1636365	5007099	7N4014	N7012A
OR8253	109863	1636367	5007085	7S8336	277730
OR8328	109809	1647557	109552	8H2985	N5224A
OR8329	109659	1647558	109552	8L5049	278416
OR8340	109861	1647559	109552	8S4637	281902
OR8341	109863	1647560	109287	8S894	281622
OR8442	109142	1647561	109287	8S9915	281902
OR9013	109552	1647562	109287	9L1167	277451
OR9626	109659	1647563	109604	9L1414	277739
OR9756	109451	1647564	109863	9L2190	277694
OR9757	5004880	1647565	107508	9L3293	279995
OR9762	109603	1647566	109142	9L3613	280540
OR9763	109604	1647567	109142	9L3664	280520
OR9764	107509	1662628	5005503	9L3775	280556
OR9765	107508	1671288	5005790	9L3872	281157
OR9766	109251	1756779	5006570	9L3872	282023
OR9900	5006570	1789497	5001940	9L4092	281021
OR9901	5007085	1803957	5001940	9L4104	284068
OR9903	5007099	1855140	109861	9L4579	282023
1029551	109139	1855145	109142	9L5366	284068
1029553	109142	1H4559	N5060D	9L5368	279995
1043823	107981	1M7512	N5060D	9L5369	281021
1067851	109552	1P5010	277730	9L5391	281021
1067852	109552	1P5011	284003		
1069089	107981	1P5012	283996	9L5408	284310
1091317	109251	1P5013	277731	9L584	227321
1091318	109287	1S2024	227407	9L866	227327
1092996	107981	2M1572E	284662	9M403	277731
1102751	109659	2P7800	285651	9M5475	227471-300
1105764	109335	2S2764	277731	9M5475	279073-500
1105766	109287	2S2765	277730	9S9741	283530
1137665	109603	2W5134	101884	9S9742	283530
1137666	109604	2W5135	289349	9S9743	283533
1170070	109809	2W6835	289336	9Y6320	108992
1182798	109861	2W9270	104042	9Y8061	107526
1182806	109863	4N1563	285131	IN2992	103278
1221713	109552	4N3927	283533		
1228966	107514	4N5964	285131	P5S8049	281184
1259562	107981	4N6954	286546		
1266110	107514	4N7378	286552	P7S1729	281195
1268214	5000292	4N7634	227407	2158055	109861
1268214	5000859	4P0586	109604	2389542	104039
1316679	109861	4P0596	107981	2389543	106439
		4P0619	109603		
		4P0676	107509		

**O E M  
I N T E R C H A N G E**

# O.E.M. TO PRIOR INTERCHANGE



O E M I N T E R C H A N G E

CUMMINS	PRIOR
Part No.	Part No.
3069181	107507
3069211	107506
3074470	107506
3074471	107507
3005840	3018542
3010879	3018542
3015034	3018542
3015630	3024365
3016082	3018542
3018527	3018542
3018530	3018542
3018531	3018542
3018534	3024365
3018541	3018542
3018542	3018542
3018543	3024365
3018544	3024365
3018545	3024365
3018551	3024365
3018553	3024365
3018555	3024365
3024365	3024365
3028532	3028532
3166445	107506
3166446	107507
3417958	107506
3417959	107507
3558022	3558022
3558094	3558094
3609998	107507
3609999	107506
3905686	104102
3905724	104103

Detroit	Prior
Part No.	Part No.
23505234	107622
23505235	107623
23509780	107813
23511334	107622
23511735	108110
23514143	5005875
23514502	107513
23514503	109647
23516840	109425
23516841	109426
23522122	109425
23522123	109426
23522852	5003852
23524143	5005875
23526795	5003852
23529487	5013157
23550462	5000603
23550463	5000602
23550476	131075
23550477	131076
23550709	131075
23550711	5000603
23550716	5000602
23550719	131076
5241310001	5003153
5311300005	5001912
5361300005	5001911
E23529487	5013157
R23505234	107622
R23505235	107623
R23509780	107813
R23522122	109425
R23522123	109426
R23529487	5013157
R3505234	107622
R3505235	107623
R3511334	NT7005AK
R3516840	109425
R3516841	109426

FORD	PRIOR
Part No.	Part No.
C2A2875E	283508
C4TA2875A	275804
C4TA2875B	277127
C5TA2875A	279037
C5TA2875B	278985
C5TA2875C	280385
C7TA2875A	279865
C7TA2875E	279865
C7TA2875F	277127
C7TA2875G	279037
C7TA2875H	275804
C7TA2875J	283517
C7TA2875K	279037
C7TA2875L	277127
C8HA2875H	277127
C8HA2875B	275804
C8HA2875C	227323
C8TA2875B	227402
C9HA2875A	277127
C9HA2875B	275804
DOHA2875B	283513
DOHA2875C	283505
DOHA2875E	227323
DOHA2875F	281286
DOHA2875H	283515
DOHA2875J	283507
DOHA2875K	286845
DOHA2875L	283514
DOHA2875M	276961
D1HA2875AA	284762
D1HA2875CA	283512
D1HA2875GA	283503
D1TA2875BA	281602
D2HZ2875A	285866
D8HS2875AA	289789
D8HS2875BA	289789
D9HS2875AA	101158
E1HS2875BA	102598
E1HT2875JB	281402
E3HT2875EB	281402
E4HT2875LA	289688
E0HT2875N2A	281402
E6HT2875DB	103211
E6HT2875FA	104041
E7HT2875BA	104041
E8HT2875BA	103211
E8HT2875FA	107221
EDE5HT2875FA	104041
EOHS2875AA	289789
EOHS2875CA	101158
EOHS2875DA	101158
F1HT2875AA	107866
F1HT2875BA	107514
F1HT2875BB	107514
F1HT2875CA	106986
F3HT2875DA	108854
F3HT2875EB	108790
F3HT2875FA	108804
F3HT2875FB	108804
F3HT2875FC	108804
F7HT2875AA	107866
FT330360391HD	279037 A/C
FT330360391HD	227446 W/C
FT330360391HD	228366 W/C
EDL401477534	229077 W/C
EDL401477534	229078 W/C
EDM401477534	229077 W/C
EDM401477534	229078 W/C
EDN401477534	229077 W/C
EDN401477534	229078 W/C
1316679	109861

G.M.	PRIOR					
Part No.	Part No.					
2235978	281430		2497261	227402	12470332	5001940
2235979	228141		2498267	280490	12546827	107981
2236318	N6000B		2499019	280517	15025056	5001940
2259006	N5098W		2499051	280891	15152068	5001940
2333413	N5212A		3813193	227407	15155242	5003553
2336114	275007		3813194	227407	15609213	286582
2338950	N5212A		3831110	228346	15666202	108066
2357663	N5060D		3876238	227403	15674783	108066
2390004	276111		3887617	227407	15742181	108066
2390021	N5217G		3887618	227321	15977688	107981
2390022	N6400		3888474	227321	15978946	107981
2390023	N6300		3906464	227321	15987055	109451
2403207	N5902E		5138834	276166		
2411907	N6300		5138835	276111		
2411999	N5902E		5144300	276166		
2414638	N6300E		5144301	276911		
2423958	229694		5144302	276961		
2428602	276111		5144303	276962		
2428604	227321		5144304	280609		
2429194	N5904G		5144305	280570		
2436537	276911		5144306	275725		
2436538	276962		5145614	227408		
2455878	228140		5145615	227409		
2457476	N6400E		5145616	227331		
2460427	227407		5145617	227332		
2461678	N6300		5145618	283644		
2461679	N6300E		5145619	228479		
2461680	N6400		5145620	283664		
2468827	279176		5147431	285252		
2470525	N5217G		5148317	279384		
2474052	227406		611900	N5904J		
2474053	227402		645387	N5217		
2474966	N5601C		651385	N6300		
2474990	N6000B		651386	N6400		
2477025	228141		683070	N5601E		
2480399	N6000B		683072	N5217G		
2480970	N6400		683073	N5601E		
2480971	N6300		683074	N5217G		
2480972	N5217		701210	282928		
2480973	227406		8867175	227323		
2480974	281978		8877955	227323		
2480975	275580		8921206	289924		
2480986	279046		8921208	289941		
2486399	228140		23505235	107623		
2488039	276911		23516841	109426		
2488040	276962		R3505235	109868		
2489301	280525		23511735	108110		
2489302	280609		23505234	107622		
2492130	227321		2350534	109867		
2493844	280239		23509780	107813		
2493889	276166		23550462	5000603		
2493890	276111		23550463	5000602		
2495698	228141		23550476	131075		
2495699	227323		23550477	131076		
2496492	N6000B		23550709	131075		
2496493	228141		23550711	5000603		
			23550716	5000602		
			23550719	131076		

**O E M I N T E R C H A N G E**

# O.E.M. TO PRIOR INTERCHANGE



O E M I N T E R C H A N G E

IHC	PRIOR				
Part No.	Part No.				
97193R91	N6300	343270C91	280784	476524C91	284718
130573R91	283690	344807C92	280622	476525C91	283690
143018R91	N6300	346892C91	281086	480214C91	285131
149628R91	N6300	348566C91	228344	480446C91	281042
179022R91	N6300	356847C92	280611	480951C91	281042
261187C93	N5706L	366181C91	227331	511052C91	285591
261187R93	N5706L	366182C91	N5706A	511629C91	285707
276468C93	N2706L	366182C91	228140	570291C91	284718
276468C93	227331 BREATH. R	366797C91	280790	606128C91	279248
276468C93	227332 BREATH. L	366840C91	275777	673443C91	282938
278668C92	N5502F	389875C91	281533	767257C91	280622
280361C91	N5706A	391240C91	279314	769577C91	280605
280361C92	N5706A	391996C91	280610	769976C91	279838
280607C91	227323	391997C91	283970	789205C91	280525
280688C91	227401	398566C91	N5601C	861438R91	N5235C
281759C93	227331	398567C91	N5303J	861446R91	N5217
285085C93	276111	398567C92	227322	861446R91	N5706
285086C91	N5706A	398568C91	N5303H	861446R91	228140
285086C91	276111	398568C91	227320	861447R91	N5160
285086C92	N5706G	398568C92	227320	861447R91	N5601
285086C93	N5708C	398569C91	N5502G	861447R91	N6400
285238C91	227323	398570C91	227400	861447R91	227406
287668C91	N5502F	398571C91	227401	861447R91	227406
287688C92	N5502F	398572C91	227406	861447R93	227407
290993C91	N5706L	398573C92	227407	861447R92	N5601C
291691C91	279707	400468C91	N5909C	861447R93	N5601C
291691C91	N5235C	400669C91	N5235C	861488R91	N5098W
292495C91	227403	400670C91	N5708BA	861488R91	N5303E
292496C91	227321	400671C91	N5706K	861488R91	N6300
295243C91	N5909C	400672C91	N5706L	861488R91	227402
295243C92	N5909C	400673C91	N5709C	861488R91	227403 BREATH. L.
295435C91	N5303C	400674C91	N5706BC	861488R92	227404
295435C91	227405	400675C91	N5706BA	866629R91	N5215
297763C91	227400	400676C91	283462	866629R91	228443 BREATH. R.
300640C91	279707	400677C91	283459	866629R91	229525 PIPE TAP HEAD
300640C92	279707	400678C91	285806	866781R91	N5215
302508C91	N5120	400679C91	283453	866781R91	280962
302508C91	N5708C W/TACH DR.	400680C91	283450	869375C91	276911
302508C91	227321BREATH. L	400681C91	283447	869711R91	N5120
302508C91	228140 BREATH. R	400682C91	281731	869711R91	227320 BRE. RIGHT
302508C92	N5708BA	400683C91	283441		PIPE TAP HEAD
304439C91	N5236C	400684C92	283438	869711R91	227322 BREATH. L.
306376C92	N5502G	408488C91	276111		PIPE TAP HEAD
308476C91	N5235C	409874C91	279707	869935C91	227407
319365C91	N5709B	409908C91	N5904BA	870560C91	276962
319365c91	228479 W/TACH DR.	411708C91	284106	874706R91	N5303E
319365C91	282986	412082C91	283967	874706R91	227403
319371C91	228479	418255C91	285158	874706R92	227403
321309C91	N5236C	418256C91	280238	874707R91	227321
326402C91	280565	476527C91	N7002A	874707R93	227403
326668C91	228346	423754C91	285370	988637R91	275231
327438C91	N5706K	427591C91	N5904BA	989483R91	276978
327438C91	227322	428617C91	284933	990002C91	N5235C
337806C91	228344	440669C91	N5235C	990003C91	N5502F
338440C91	281220	467418C91	281042	990003C92	276111
338444C91	N5601M	467876c91	283690	990004C91	N5706K
338444C91	228344	468579c91	280962	990005C91	N5120
338900C91	N5706L	476521C91	283690	990005C91	N5708C BREATH. R.
		476522C91	280962		W/ TACH DR.
		476523C91	281042	990006C91	N5706A

IHC	PRIOR
Part No.	Part No.
990007C91	N5303J
990007C91	227404
990012C91	N5502G
990024C91	N5909G
990051C91	N5236C
990061C91	N5236C
990062C91	N5709B
990062R91	282986
990081C91	N5601M
990081C91	227406
990105C91	N5706A
990176C91	N5601M
990176C91	227406
990177C91	N5303J
9900177C91	227403
990178C91	227404
990179C91	N5502G
990179C91	281112
990180C91	N5909C
990181C91	N5235C
990182C91	N5708BA
990183C91	N5706K
990184C91	N5706L
990185C91	N5709C
990188C91	N5706BC
990187C91	N5706BA
990188C91	N5904BA
990209C91	227406
990210C91	227404
990271C91	227407
990418C91	281042
990419C91	280962
990420C91	284718
990421C91	283690
994866C91	280962
997064R91	N5601C BREATH. R.
997064R91	N6400 PIPE TAP HEAD
997064R91	227406 BREATH. R.
997064R91	227407 BREATH. L.
997065R91	N5098AW BREATH. L.
	PIPE TAP HEAD
997065R91	N5098W BREATH. R.
	PIPE TAP HEAD
997065R91	N5303D BREATH. R.
997065R91	N5303E BREATH. L.
997065R91	N6300 PIPE TAP HEAD
997065R91	227402 BREATH. R.
997065R91	227403 BREATH. L.
997065R91	227404
997066R91	N5217 BREATH. L.
997066R91	N5706A BREATH. R.
997066R91	228140
997084R91	N5215
997084R91	228443
997084R91	229525 PIPE TAP HEAD
997104R91	227403
997105C91	N5706A
997105C91	228140

997109R91	N5303E
997109R91	227403
997110R91	N5706G
997110R91	227321
997123R91	N5120 BREATH. L.
997123R91	N5706A BREATH. R.
997123R91	227320 BREATH. R.
997123R91	227322 BREATH. L.
997153R91	N5706L
997153R91	227331 BREATH. R.
997153R91	227332 BREATH. L.
1516307C91	107513
1657974C91	108110
1672563C92	107506
1672564C92	107507
1675722C91	106439
1680209C91	106439
168541C91	106439
1686542C91	108110
1688704C91	108110
1689954C91	107514
1691205C91	108110
1694005C91	109088
1694005C92	109088
1694006C91	107506
2003252C94	109088
1694007C91	107507
1694953C91	107514
1696864C91	109111
1696864C92	109111
1829993X101	5002973
2003252C94	109088
2003252C95	109088
2003252C97	109088
2003253C94	109111
2003253C95	109111
2003253C97	109111
3551971C92	107514
3551971C92	107514
3565547C91	5014488
3565547C92	5014488
3565548C91	5014489
3565548C92	5014489
3596420C91	5014144
3596420C92	5014144
3596421C92	5014489
3596421C93	5014489
3599754C91	5014488
3599754C92	5014488
3605399C91	107514
BX107622B1	107622
BX108110B1	108110
53403C91	289339
534043C94	289339
540514C91	289350
540514C93	289350
540515-93	101158
540515C91	101158

# O.E.M. TO PRIOR INTERCHANGE



O E M I N T E R C H A N G E

MACK	PRIOR
Part No.	Part No.
303GB104P5	277122
303GB1148A	227326
303GB1148A	280608
303GB1148A	N5222
303GB1152	229562
303GB1153	227328
303GB1176	227326
303GB1178	227326
303GB1179	227415
303GB3112	280570
303GB3118	278606
303GB3119	284370
303GB390A	278606
303GB394	278606
303GB4104P5	277122
303GB4112A	227415
303GB4120	275834
303GB4131	277799
303GB4132	277808
303GB4132P2	279321
303GB4133	277901
303GB4133P2	277901
303GB4134	278452
303GB4134P2	278452
303GB4135	278416
303GB4140	278776
303GB4143	279483
303GB4148	280501
303GB4149	280608 500
303GB4152	280628 600
303GB4154	281078
303GB4161P1	284307
303GB4161P2	285107
303GB4162P1	284307
303GB4162P2	285107
303GB4163	227326
303GB4165	277122
303GB4165A	277122
303GB4165P5	277122
303GB4170P1	284307
303GB4170P2	285107
303GB4170P3	284307
303GB4170P4	286221
303GB4172	280501
303GB4173	229562
303GB4174	275834
303GB4177	284711
303GB4178	282586
303GB4179	277122
303GB4180	277122
303GB4181	284662
303GB4182	285275
303GB4183	285275
303GB4184	284662
303GB4185	285827
303GB4186	284662
303GB4200R	289348

303GB4201R	289340
303GB4203	102290
303GB4204	289348
303GB589	289340
303GB590	289340
303GB491A	227402
303GB5103	107510
303GB5105	107511
303GB5109	107869
303GB5113A	108869
303GB5114	108866
303GB5124	107510
303GB554P1	227326
303GB554P1	N5222
303GB554P2	227328
303GB554P3	229562
303GB561P1	278604
303GB561P2	278605
303GB561P3	278606
303GB561P4	277901
303GB561P5	279556
303GB561P6	279556
303GB569AP3	282586
303GB569P1	282586
303GB569P2	282620
303GB569P3	282586
303GB570P1	277326
303GB571P1	277901
303GB571P4	277901
303GB572P1	282586
303GB572P2	282620
303GB572P4	283813
303GB572P5	284662
303GB578	284662
303GB580PR1	286544
303GB587	284662
317GB412	278416
317GB4722	283805

VOLVO	PRIOR
Part No.	Part No.
3093850	107981
3946077	108937
3946078	108935
3949430	107512
3949432	107623
8022813	108935
8022814	108937
8062235	107507
816665	107981
85101164	107509
85102167	108804
85102168	107622
85102169	107507
85102173	108866
85102174	109088
85102179	107514
85102181	108869
85102184	107813
85102188	108110
85106353	107510
85106354	109425
700010015	289789
700010016	289339
700010019	289349
700010043	107508
700013205	107622
700018001	107506
700018003	109604

WHITE	PRIOR
Part No.	Part No.
904315	289339
DDAD	104039
Y449675	N5085W
Y551797	280963
Y622152	N5085DW
3103057	280626
511338	229525
538359	280963
541799	227326
544264	281042
545201	281128
545282	227320
547406	281677
554528	281718
555282	227320
564393	280611
566163	280602
566254XRL	229525
567753	282013
569133	279995
569545	282749
569989	228479
573751	283026
5144303	276962
621442A	227409
621443B	227331
622700A	227410
622701A	227410
622701B	227332
623080	N5085DW
688861	276775
689294	229525
7000222	284068
70002212	284160
7010634	284718
7010639	284718
7010640	284720
7100724	280453
7101850	284259
7115252	281042
71116024	284160
7118271	280556
879675	229525

**BX2150**  
9 1/2 CFM @ 1250 RPM  
PIC #1



**TF400**  
7 1/4 CFM @ 1250 RPM  
PIC #2



**TF500**                      **TF600**  
12 CFM @ 1250 RPM      14 1/2 CFM @ 1250 RPM  
PIC #3



**TF501**  
12 CFM @ 1250 RPM  
PIC #4



**TF700**  
15 1/2 CFM @ 1250 RPM  
PIC #5



**DURAFLO 596**  
27 CFM @ 1250 RPM  
PIC #6



**C  
O  
M  
P  
R  
E  
S  
S  
O  
R  
S**

ALL COMPRESSORS ARE FURNISHED LESS GOVERNORS, PULLEYS, STRAINERS AND FITTINGS

**TF 550**  
**13.2 CFM @ 1250 RPM**  
PIC #7



**TF 750**  
**16.5 CFM @ 1250 RPM**  
PIC #8



**BA 921**  
**15.8 CFM @ 1250 RPM**  
PIC #9



**BA 922**  
**31.6 CFM @ 1250 RPM**  
PIC #10



**TF 1000**  
**24 CFM @ 1250 RPM**  
PIC #11



**TF 1400L**  
**31 CFM @ 1250 RPM**  
PIC #12



**C  
O  
M  
P  
R  
E  
S  
S  
O  
R  
S**

ALL COMPRESSORS ARE FURNISHED LESS GOVERNORS, PULLEYS, STRAINERS AND FITTINGS

**WABCO-250 - 75MM**  
**15.2 CFM @ 1250 RPM**  
PIC #13



**WABCO-318 - 85MM**  
**18.7 CFM @ 1250 RPM**  
PIC #14



**WABCO-636**  
**37.4 CFM @ 1250 RPM**  
PIC #15



**C  
O  
M  
P  
R  
E  
S  
S  
O  
R  
S**

P

ALL COMPRESSORS ARE FURNISHED LESS GOVERNORS, PULLEYS, STRAINERS AND FITTINGS

EL850  
MIDLAND BASE MOUNT  
PIC #16

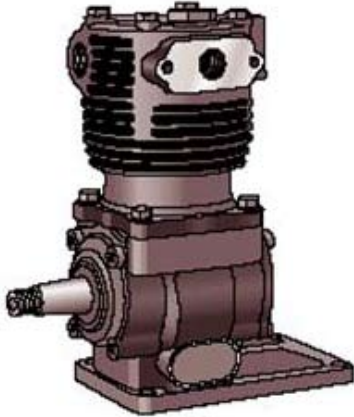

EL850  
MIDLAND FLANGE MOUNT  
(CUMMINS APPLICATION)  
PIC #17

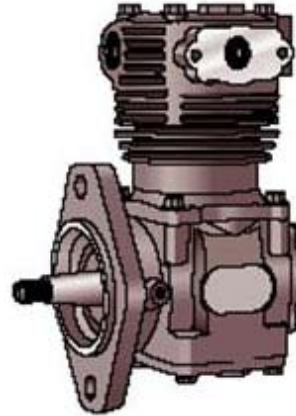

EL740  
2-CYLINDER 7 1/4  
MIDLAND BASE MOUNT  
PIC #18



2-CYLINDER 12-CU. FT.  
MIDLAND BASE MOUNT  
PIC #19

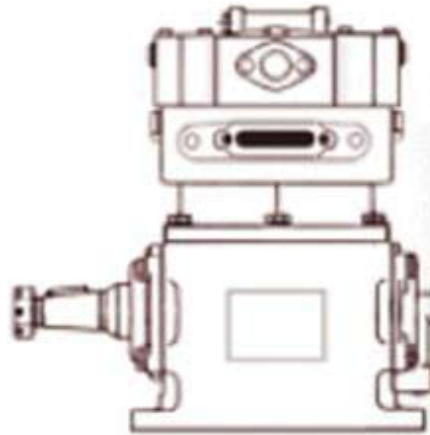

EL1300/EL1600  
PIC #20

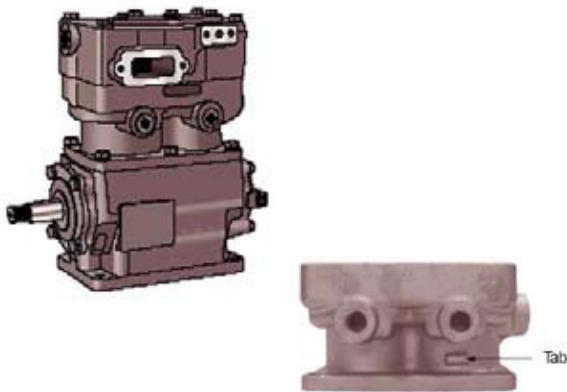

\*Note: Tab on block indicates EL1600 type. No tab = EL1300 type.

EL3200  
PIC #21

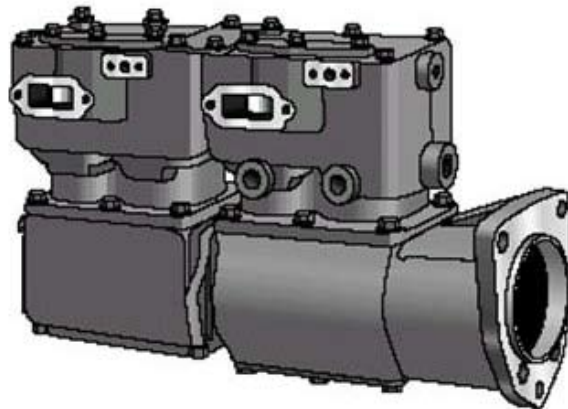

C  
O  
M  
P  
R  
E  
S  
S  
O  
R  
S

ALL COMPRESSORS ARE FURNISHED LESS GOVERNORS, PULLEYS, STRAINERS AND FITTINGS

**N 14**

3018527  
3018532

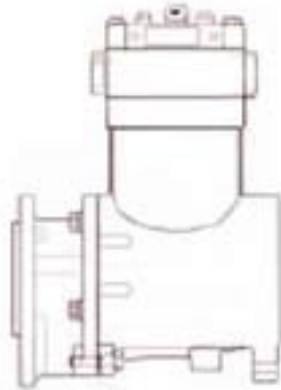

PIC #22

**NT**

3558020 338 E Type  
3558045 296 E Type  
3049186 296  
3558015 338

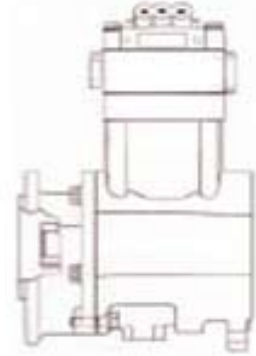

PIC #23

**V903**

3018550  
\* Female threaded shaft

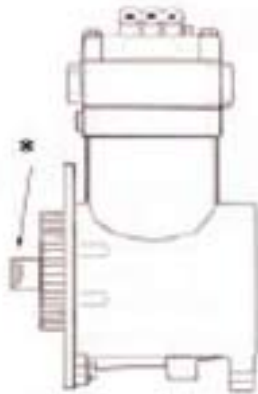

PIC #24

**L10 / N 14**

3558016 338  
3047440 296  
3558013 338 E Type  
3558044 296 E Type

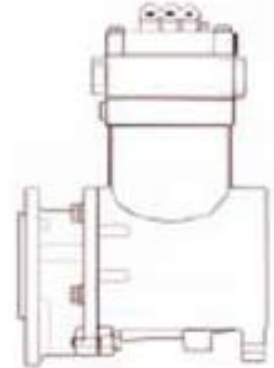

PIC #25

**K 19**

3558046 296 E Type  
3052776 296  
3558047 338 E Type

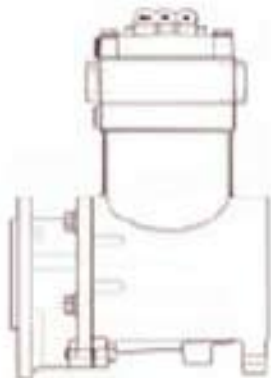

PIC #26

**L10 LNG**

3558080 338 9 Tooth Spine

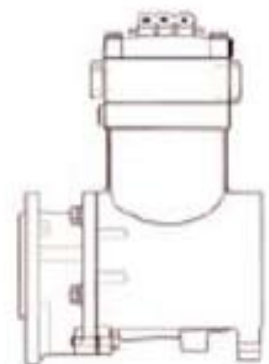

PIC #27

**L10 / N14 / M11**

- 3558072 QE296
- 3558074 QE338
- 3558131

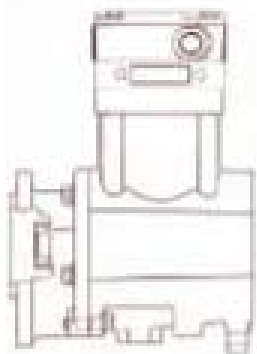

PIC #28

**V 28**

- 3558035

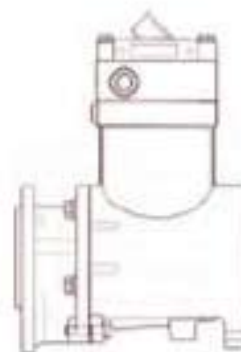

PIC #29

**SS style Mack  
E6 / E7  
thru drive  
11 tooth spline**

- 3558029 SS296
- 3558000 SS338

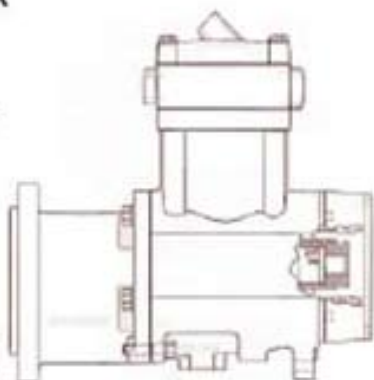

PIC #30

**SS style Mack  
E6 / E7  
non thru drive**

- 3558042 SS296
- 3558043 SS338

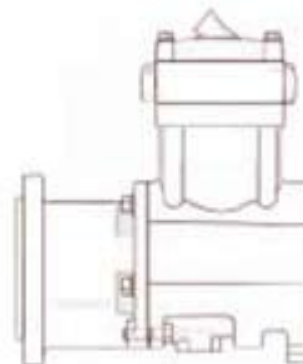

PIC #31

**HD & QE style Mack  
E6 / E7  
non thru drive**

- 3558068 QE296
- 3558077 QE338
- 3558107 HD650
- 3558110 HD850

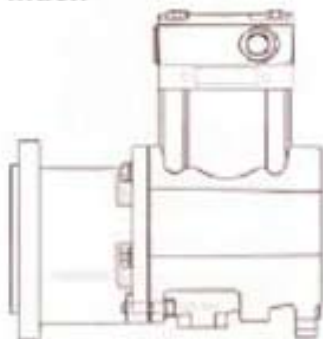

PIC #32

**HD & QE style Mack  
E6 / E7  
thru drive  
11 tooth spline**

- 3558075 QE296
- 3558076 QE338
- 3558108 HD650
- 3558109 HD850

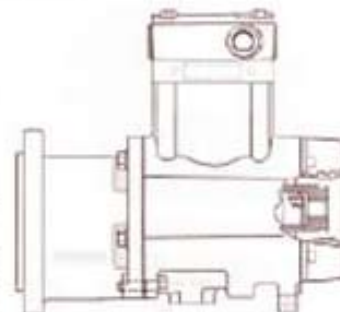

PIC #33

**HD & QE style Mack  
E Tech  
non thru drive**

3558144 296 E Tech  
3558145 338

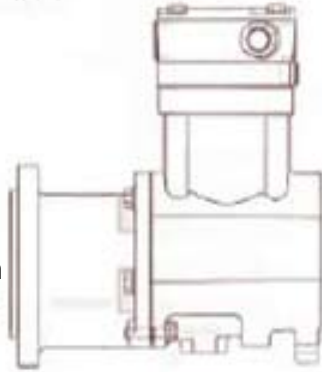

PIC #34

**HD & QE style Mack  
thru drive**

3558146 296 11 tooth  
3558147 338 11 tooth

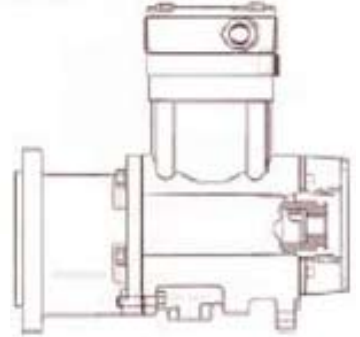

PIC #35

**QE style Mack E5 / Renault  
non thru drive**

3558092 E5/Renault  
3558093 E5/Renault

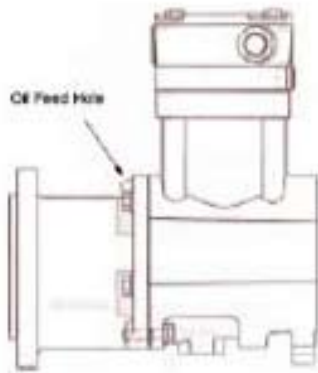

PIC #36

**B Series  
11 Tooth spline**

3558082 SS296 E Type

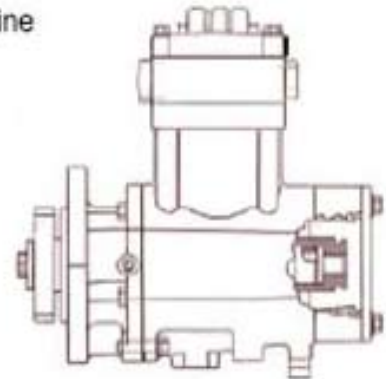

PIC #37

**B Series  
11 Tooth spline**

3558164 SS296

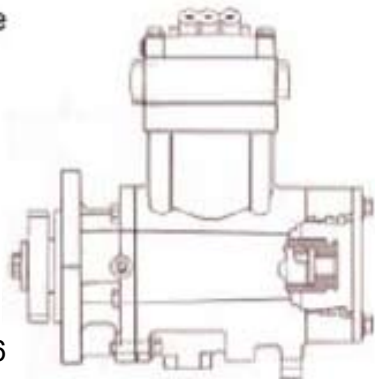

PIC #38

**B Series  
11 Tooth spline**

3558049 QE296  
3558050 QE338

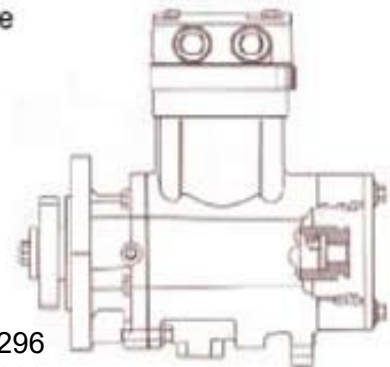

PIC #39

**B Series**  
11 tooth spline

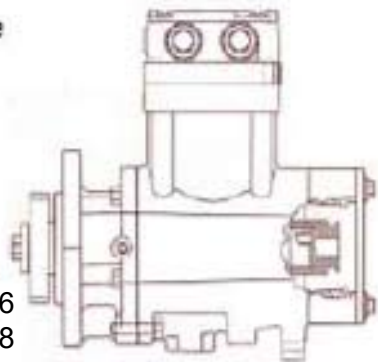

3558208 QE296  
3558209 QE338

PIC #40

**B Series**  
11 tooth spline

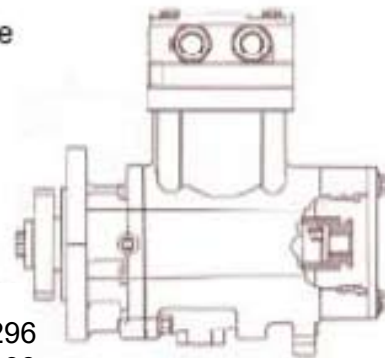

3558097 QE296  
3558098 QE338

PIC #41

**B Series**  
11 tooth spline

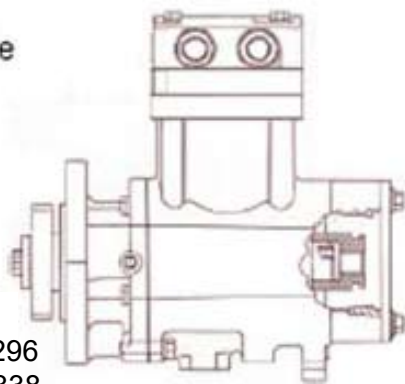

3558211 QE296  
3558212 QE338

PIC #42

**B Series**  
11 tooth spline

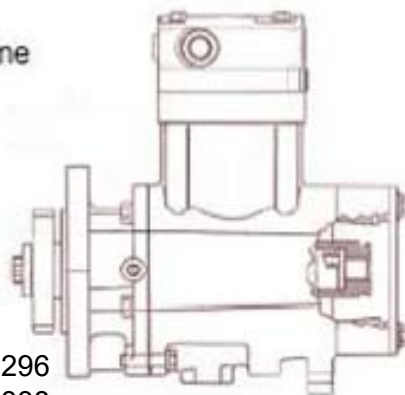

3558105 QE296  
3558139 QE338

PIC #43

**B Series**  
11 tooth spline

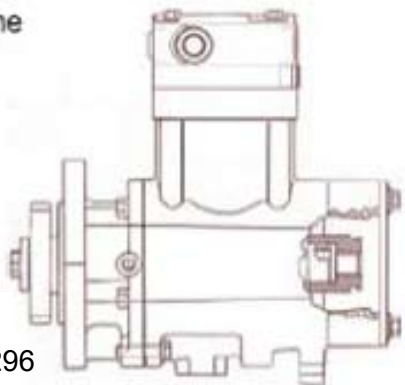

3558199 QE296

PIC #44

**B Series**  
tang drive

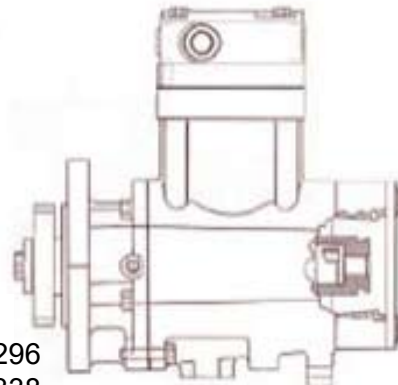

3558081 QE296  
3558102 QE338

PIC #45

**C Series**  
9 tooth spline

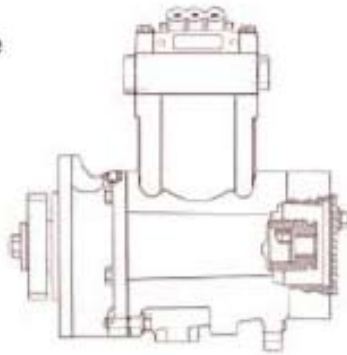

3558005 SS 296  
3558023 SS 338 E Type

PIC #46

**C Series**  
11 tooth spline

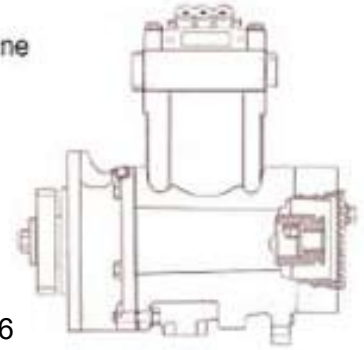

3558006 SS 296  
3558022 SS 338 E Type  
3558021 SS 338 E Type

PIC #47

**C Series**  
11 tooth spline

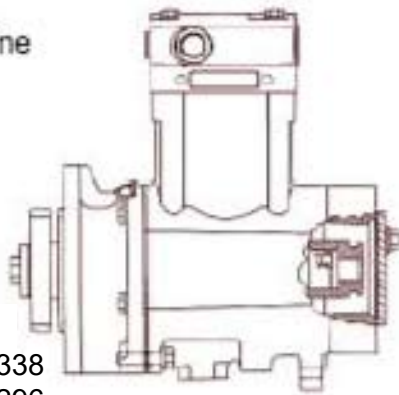

3558051 QE338  
3558052 QE296  
3558094 QE296

PIC #48

**C Series**  
9 tooth spline

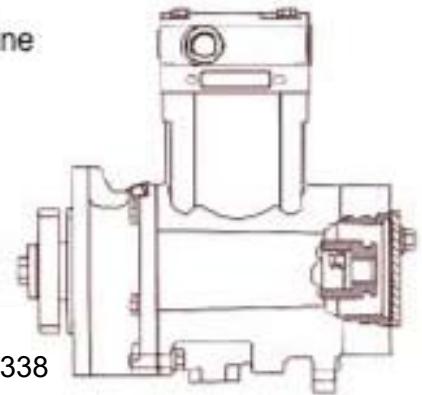

3558113 QE338

PIC #49

**C Series**  
13 tooth spline

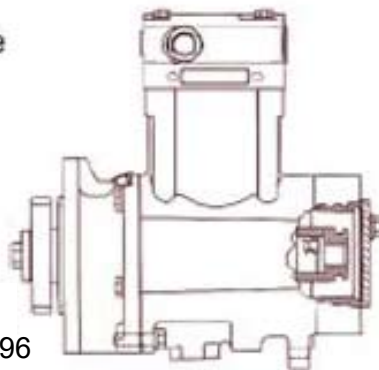

3558115 QE296  
3558116 QE338

PIC #50

**C Series**  
Out board discharge  
11 tooth spline

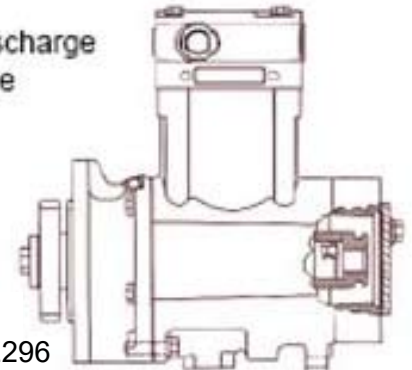

3558142 QE296  
3558143 QE338

PIC #51

Encore C Series  
11 tooth spline

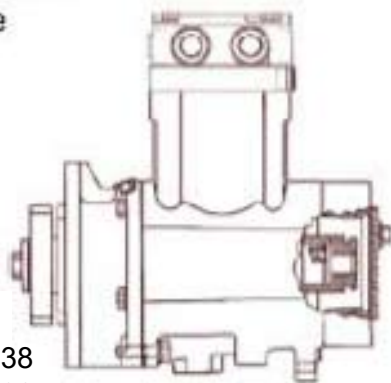

3558189 QE338  
3558186 QE296

PIC #52

Encore C Series  
13 tooth spline

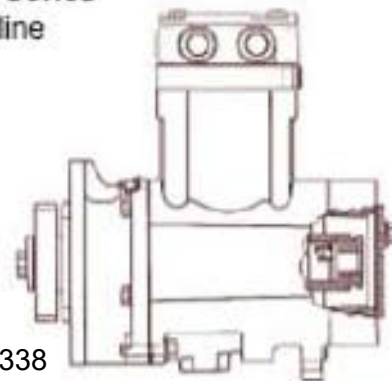

3558188 QE338

PIC #53

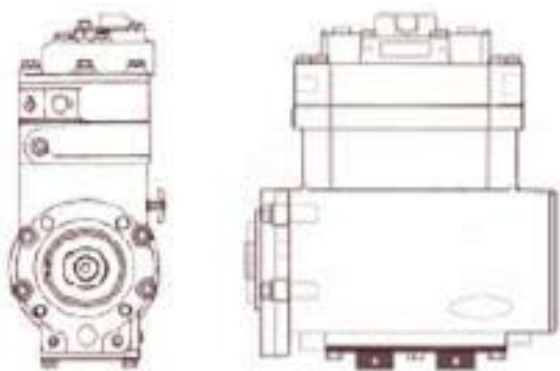

3025831 ST676

PIC #54

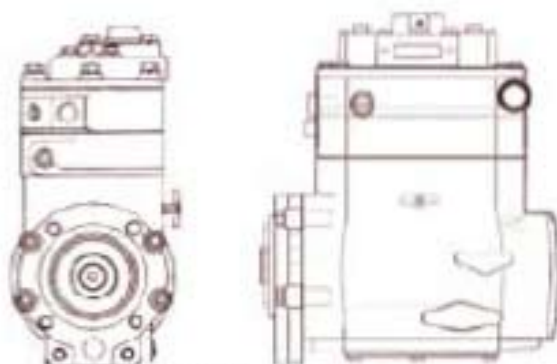

3025832 ST676

PIC #55

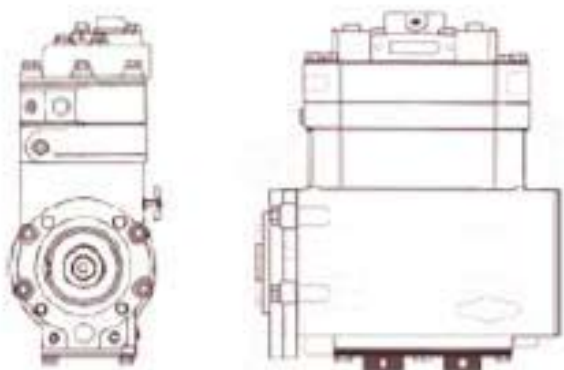

3025833 ST676

PIC #56

V903

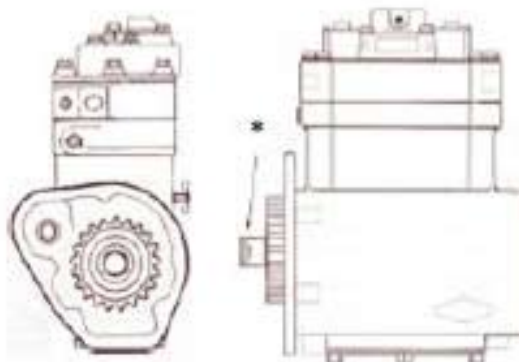

3018550 ST676  
3048673 ST676

\*Female threaded shaft

PIC #57

C  
O  
M  
P  
R  
E  
S  
S  
O  
R  
S

**K12**

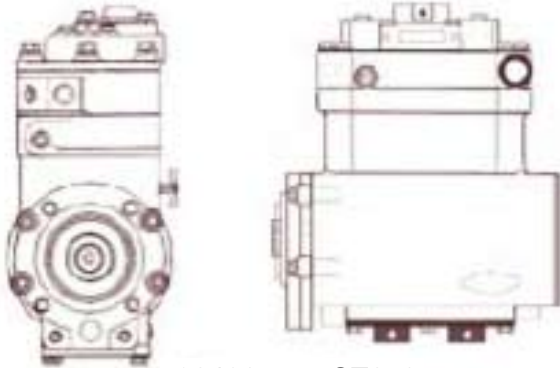

3048675 ST676  
PIC #58

**NT**

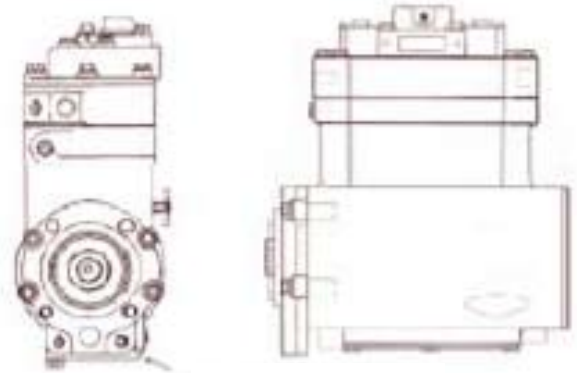

3048677 ST676  
PIC #59

**L10 / M11  
N14 (pre '91)**

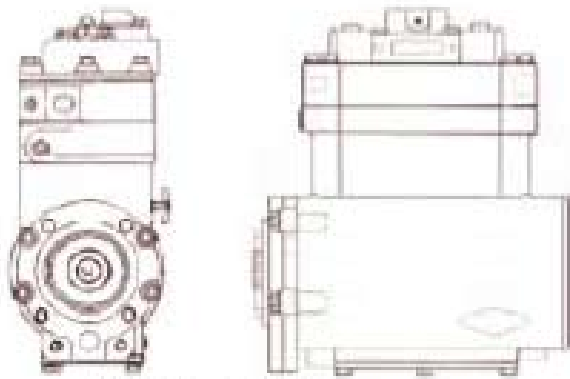

3048680 ST676  
PIC #60

**K12 / K16**

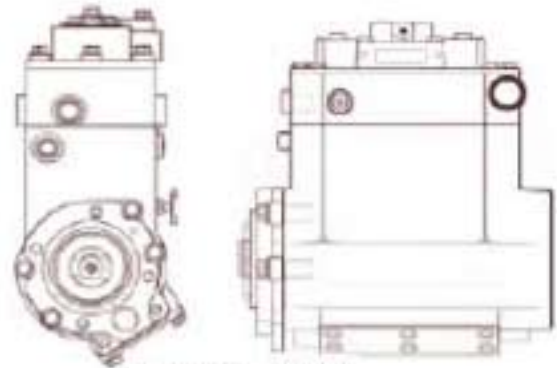

3056615 ST773  
PIC #61

**DDC**

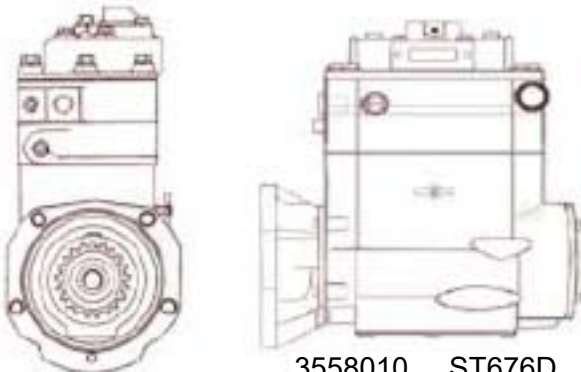

3558010 ST676D  
PIC #62

**91 NT Vertical**

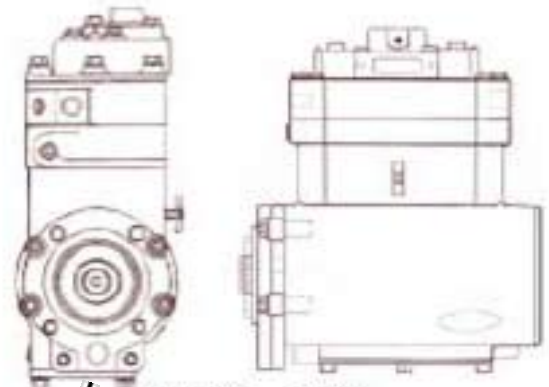

NOTE: // 3558027 ST676  
BASE OFFSET PIC #63

**C  
O  
M  
P  
R  
E  
S  
S  
O  
R  
S**

V12

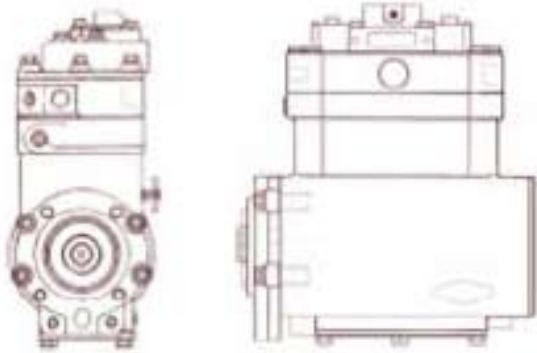

3048672 ST676  
PIC #64

DDC 35° Tilt

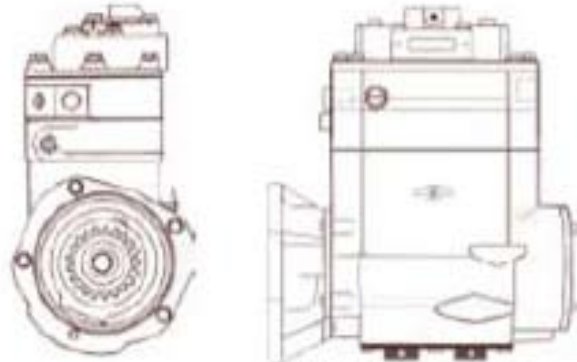

3558019 ST676D  
PIC #65

DDC 0° Tilt

3558036 ST773D

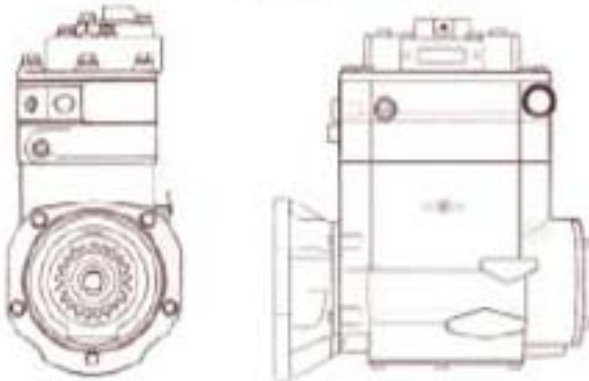

PIC #66

K19  
K Bracket

3558041 ST676

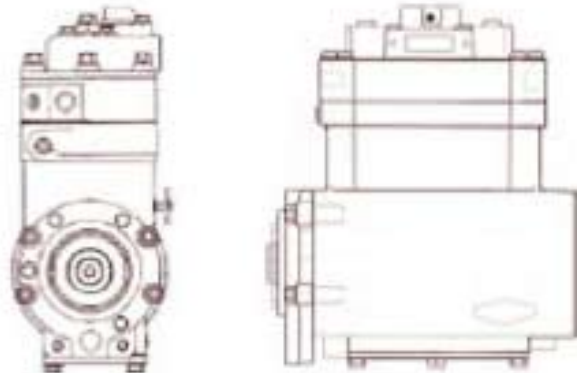

PIC #67

C  
O  
M  
P  
R  
E  
S  
S  
O  
R  
S

**TYPE 9 AIR DRYER**  
PIC #69

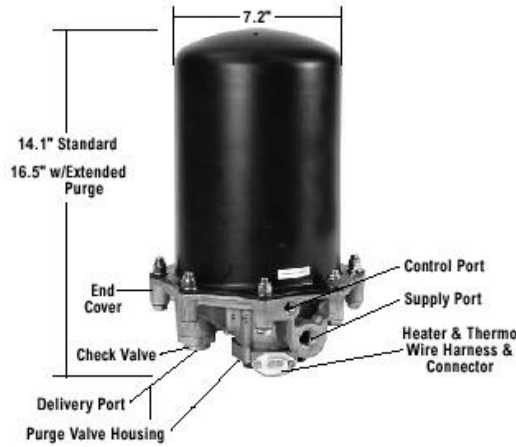

**PURGE VALVE ASSY.**  
PIC #70



Purge Valve Assembly	Purge Valve Type	Interchange Reference
5004341-S	12V	800405
5004341-H	12V	800405
5004342-S	24V	5004348
5004342-H	24V	5004348

Part Number	Supply/Del Ports	Heater Volts (75 Wyatt)	End Cover	Purge Valve Assembly	Purge Valve Seal Type	Heater & Thermo Kit	Purge Volume
065225-N	1/2" PT	12V	065231	5004341H	Hard	109578	STD

**PURGE VALVE ASSY.**  
PIC #71



Purge Valve Assembly	Purge Valve Type
5005037-N	Hard Seal Kit

**PURGE VALVE ASSY.**  
PIC #72



Purge Valve Assembly	Purge Valve Type
5005893-N	Soft Seal Kit

PIC #73

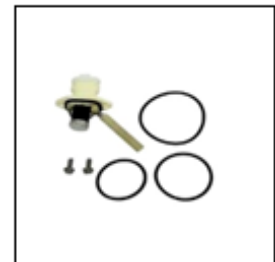

Heater & Therm.
109578 & 109579

PIC. # 74

**AD 2 AIR DRYER CARTRIDGE**



Part Number
101900-N

**AD 4 AIR DRYER CARTRIDGE**



Part Number
104358-N

**AD 9 AIR DRYER CARTRIDGE**



Part Number
107794-N

**AIR DRYERS**

**AD-SP AIR DRYER**  
PIC #75 - WEIGHT: 11 LBS.

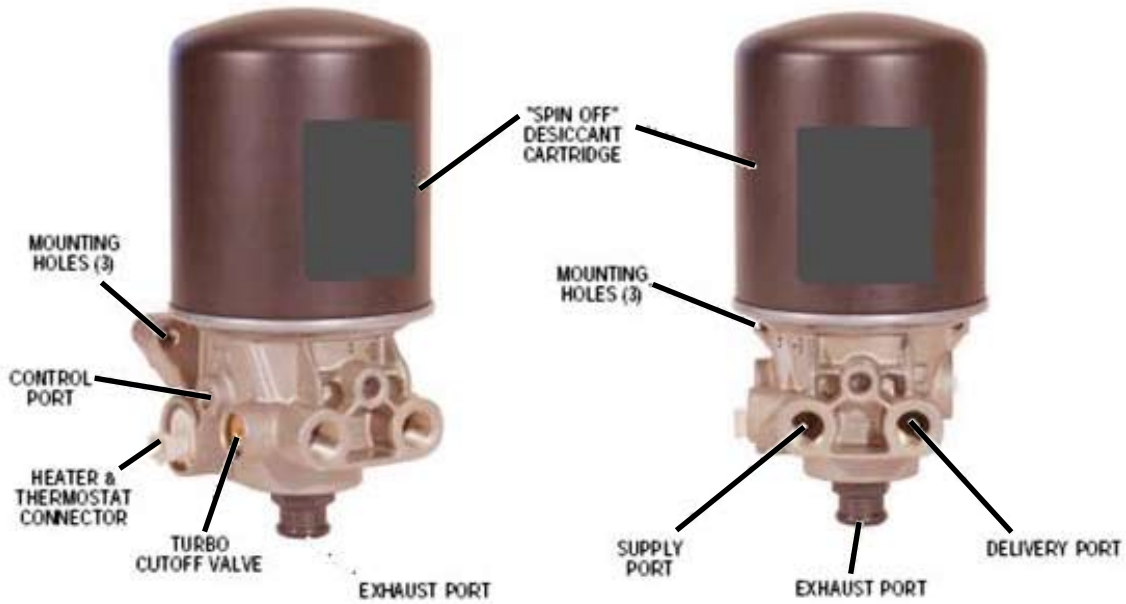

Part Number	Heater & Thermostat Volts - Wyatts	Connector Color	Kit - Purge Valve	Kit - Heater & Thermo.
065691-N	12v - 90w	White	109995	109495

PIC #76



Cartridge
109994-N

PIC #77A



Kit - Purge Valve
109995

PIC #77B



Kit - Heater & Therm.
109495

**AIR DRYERS**

**TYPE IP AIR DRYER**  
PIC #78

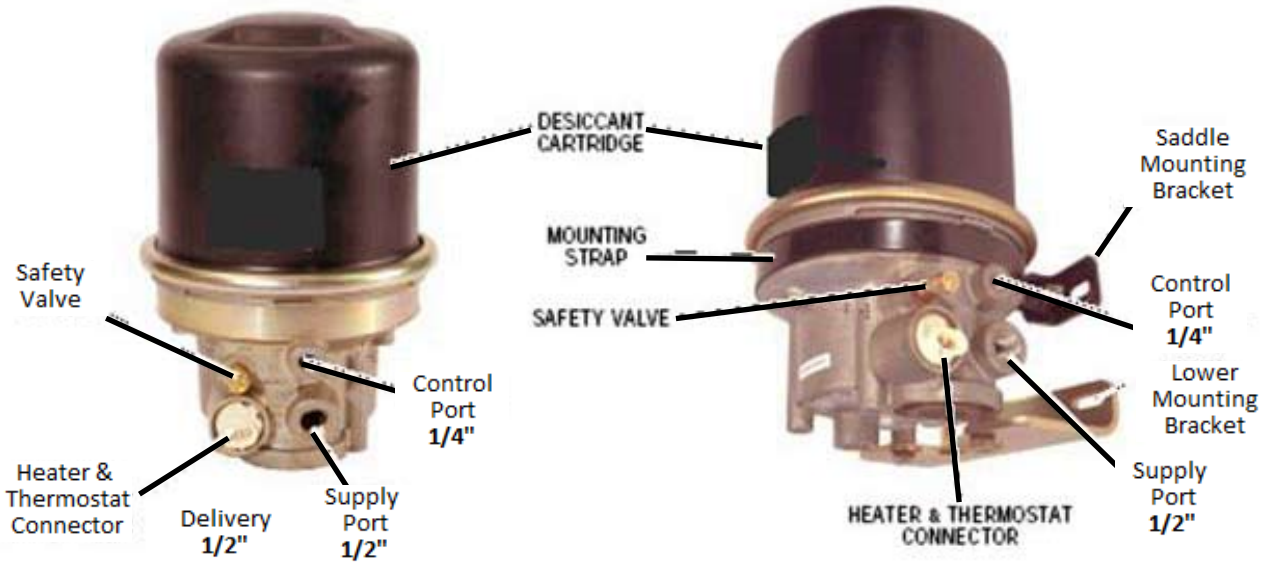

Part Number	Heater & Thermostat Volts - Watts	Connector Color
065612-N	12v - 90w	White

PIC #79



Cartridge
109493-N

PIC #80A



Purge Valve Old Style
800404

PIC. #80B



Purge Valve New Style
KO22105

**TYPE AD-IS AIR DRYER**  
PIC #81

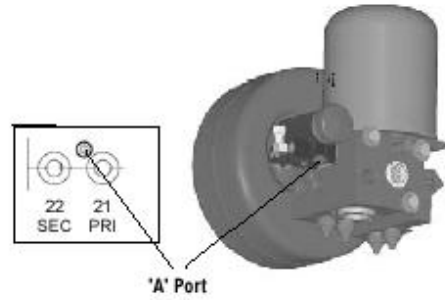
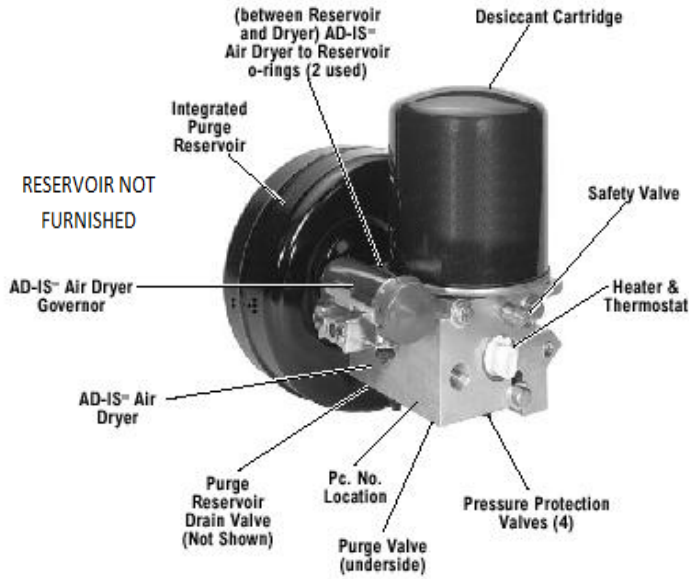

\*AD-IS air dryers with a plugged port 'A' can not be interchanged with those that do not have a port in this location.

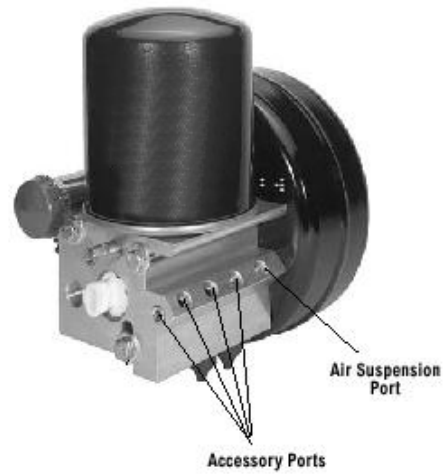

Part Number	A Port Plug	Suspension Port	Accessory Ports (Qty)	Heater Voltage (90Watt)	Primary Port	Secondary Port	Remarks
5010134-N	With	1/4" NPT	1/4" NPT (4)	12	1/4" NPT	1/4" NPT	Generic 12V

PIC #76



Cartridge  
109994-N

PIC #77B



Kit - Heater & Therm.  
109495

PIC #80



Purge Valve Old Style  
800404

**AIR DRYERS**

**WABCO SYSTEM SAVER AIR DRYER**

- \* **1200/1800**: System regeneration valve assembly on side of dryer.
- \* **1200E**: Tubing and banjo fitting at front of dryer.
- \* **1200P/1800P**: Uses dedicated purge tank. Port to purge tank drilled and tapped 1/4"-18 NPTF
- \* **1200U/1800U**: Small regeneration hole visible in back of 1/2"-14 NPTF Supply Port when fitting is removed. No spring in turbo cut-off valve assembly
- \* **1200UP/1800UP**: Uses dedicated purge tank. Port drilled and tapped 1/4"-18 NPTF Small regeneration hole visible at back of 1/2"-14 NPTF Supply Port when fitting is removed. No spring in turbo cut-off valve assembly. Dedicated purge tank.

**NOTE:**

- P - INDICATES AN EXTERNAL PURGE TANK IS USED FOR DESICCANT REGENERATION.**
- E - INDICATES A HOLSET STYLE COMPRESSOR FUNCTION**
- U - INDICATES DISCHARGE LINE - UNLOADED COMPRESSOR.**
- UP - INDICATES DISCHARGE LINE - UNLOADED COMPRESSOR (WITH EXTERNAL PURGE TANK).**

PIC. # 82A



Part Number	Type
WAB413001	1200 12 VOLT

REF. 955205

PIC. # 82B

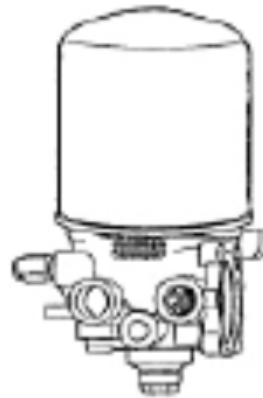

Part Number	Type
WAB721009P	1200P 12 VOLT

REF. 955300

PIC #76



Cartridge
109994-N

**MIDLAND SERIES 1 PRESSURE CONVERTER**

PIC. # 83

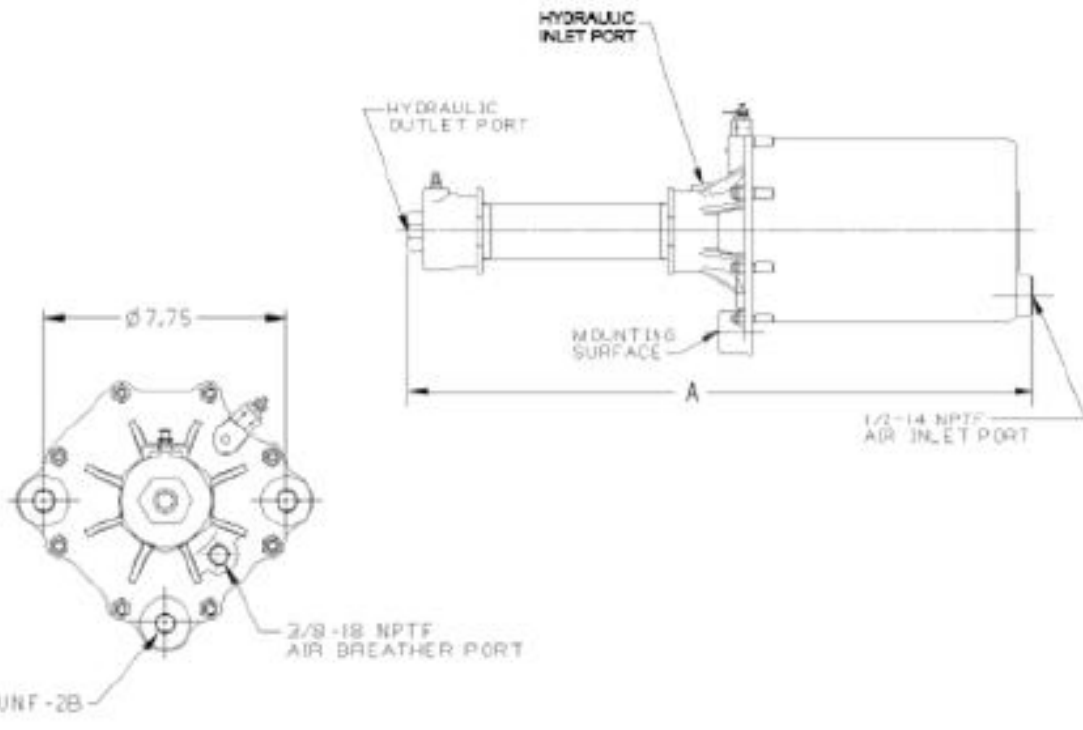
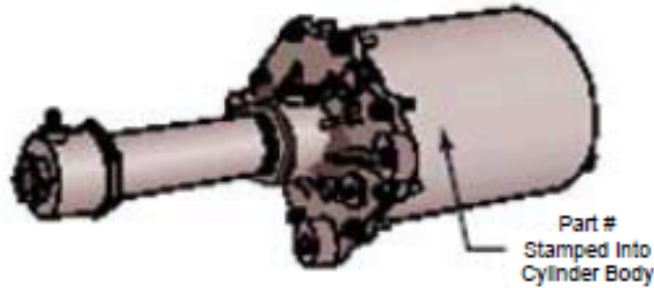

**PRESSURE CONVERTERS**

Part Number	Fluid Type	A Overall Length Inches	Air Cylinder Diameter	Hydraulic Output Port	Part Number	Fluid Type	A Overall Length Inches	Air Cylinder Diameter	Hydraulic Output Port
N4286	M.O.	17.36	6	7/8-14 O'Ring	N4274F	M.O.	17.1	6.75	9/16-18 O'Ring
N4174B	B.F.	22.7	6	1/2-20 Flare	N4194	B.F.	22.7/10	6	1/2-20 Flare
N4174E	B.F.	22.7	6	1/2-20 Flare	N4194B	B.F.	18.69	6	1/2-20 Flare
N4174F	B.F.	22.7	6	9/16-18 O'Ring	N4194D	B.F.	22.7	6	7/16-20 O'Ring
N4270	M.O.	22.7	6	1/2-20 Flare	N4194E	B.F.	22.7	6	9/16-18 O'Ring
N4270C	M.O.	22.7	6	9/16-18 O'Ring	N4294	M.O.	22.7	6	1/2-20 Flare
N4170F	B.F.	22.7	6.75	1/2-20 Flare	N4294B	M.O.	22.7	6	9/16-18 O'Ring
N4170G	B.F.	28.24	6.75	1/2-20 Flare	N4190A	B.F.	22.7	6.75	1/2-20 Flare
N4170L	B.F.	22.7	6.75	1/2-20 Flare	N4190C	B.F.	28.24	6.75	1/2-20 Flare
N4170M	B.F.	28.24	6.75	9/16-18 O'Ring	N4190E	B.F.	28.24	6.75	9/16-18 O'Ring
N4170N	B.F.	22.7	6.75	1/2-20 Flare	N4190H	B.F.	28.24	6.75	1/2-20 Flare
N4170R	B.F.	22.7	6.75	9/16-18 O'Ring	N4290A	M.O.	22.6	6.75	1/2-20 Flare
N4274	M.O.	28.24	6.75	9/16-18 O'Ring	N4290B	M.O.	28.24	6.75	1/2-20 Flare
N4274A	M.O.	22.7	6.75	1/2-20 Flare	N4290C	M.O.	28.24	6.75	9/16-18 O'Ring
N4274B	M.O.	22.7	6.75	3/8-18 NPTF	N4290D	M.O.	28.24	6.75	3/8-18 NPTF
N4274D	M.O.	22.7	6.75	9/16-18 O'Ring	N4290E	M.O.	28.24	6.75	1/2-20 Flare
N4274E	M.O.	22.7	6.75	1/2-20 Flare					

FLUIDS: B.F. = Brake Fluid, M.O. = Mineral Oil  
NOTE: DO NOT interchange Fluids

ALL VALVES FURNISHED WITHOUT TREADLE OR BRACKETS

**TYPE D2 GOVERNOR**

NOTE: ALL GOVERNORS ASSEMBLED WITH  
HIGH-TEMP SEALS AND O-RINGS  
PIC #91

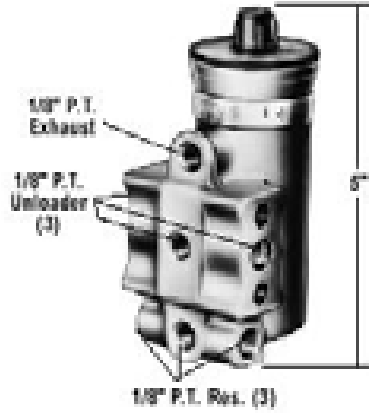

Part Number	Pressure Range
275200-N	100-120 PSI

**E-2 BRAKE VALVE**

PIC #93 - WEIGHT: 2 LBS.



Part Number	Delivery	Supply	Auxiliary
229500	3/8" PT	1/2" PT	1/4" PT
229501	1/2" PT	1/2" PT	1/4" PT

**E-3 BRAKE VALVE**

PIC #94 - WEIGHT: 2 LBS.



Part Number	Delivery	Supply	Auxiliary
279040	(4) 3/8" PT	(2) 1/2" PT	None
278998-N	(4) 1/2" PT	(2) 1/2" PT	(2) 1/4" PT

**E-5 DUAL BRAKE VALVE**  
PIC #96 - WEIGHT: 3 LBS.

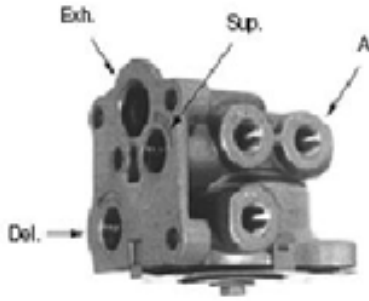

Part Number	
279950-N	
281004-N	Threaded "A" Port
285148-N	Threaded Exh.

**E-6 DUAL BRAKE VALVE**  
PIC #97 - WEIGHT: 3 LBS.

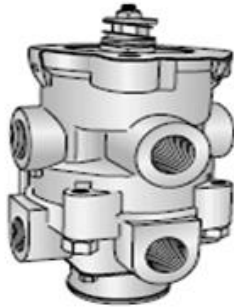

Part Number	Ports
286171-N	3/8 Sup. And Del. Ports

**E-7 DUAL BRAKE VALVE**  
PIC #98 - WEIGHT: 3 LBS.

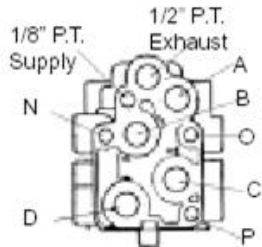

Rear View

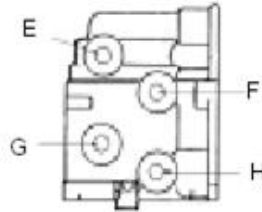

Right Side View

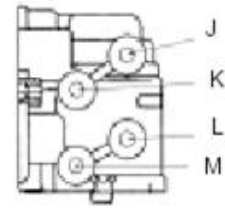

Left Side View

Part #	A	B	C	D	E	F	G	H	J	K	L	M
101818-N	1/2	1/2	1/2	1/2	1/4	3/8	1/4	3/8	1/4	3/8	1/4	3/8
284760*	O	O	O	O	1/4		1/4					
286774	1/2	1/2	1/2	1/2	1/4	1/4	1/4	1/4	1/4	1/4	1/4	1/4
287411	1/2	1/2	1/2	1/2	1/4	1/4	1/4	1/4	3/8	3/8	3/8	3/8
287564	1/2	1/2	1/2	1/2	1/4	3/8	1/4	3/8	1/4	1/4	1/4	1/4
288267	1/2	1/2	1/2	1/2	1/4	1/4	1/4	1/4	3/8	3/8	3/8	3/8
288383-N	1/2	1/2	1/2	1/2	1/4	1/4	1/4		1/4	1/4	1/4	1/4

\* O = O RING MOUNT

**E-8P DUAL FOOT VALVE**  
PIC #99 - WEIGHT: 3 LBS.

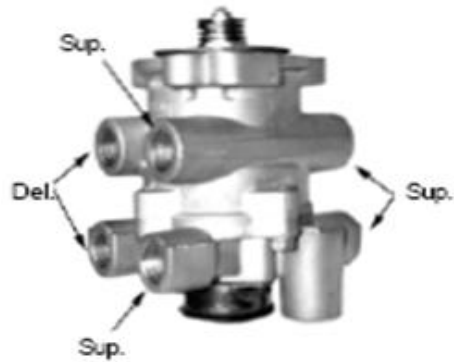

Part Number	All Ports
800629-N	3/8" PT

**E-10 DUAL FOOT VALVE**  
PIC #100 - WEIGHT: 3 LBS.

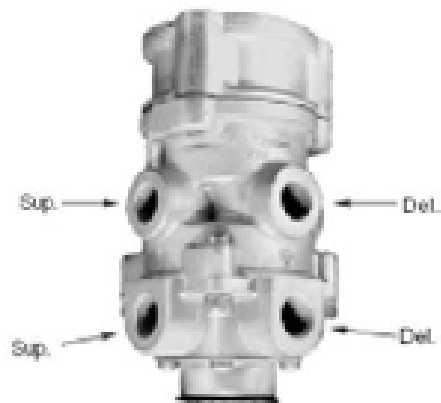

Part Number	All Ports
101100-N	3/8" PT

**E-10P DUAL FOOT VALVE**  
PIC #101 - WEIGHT: 3 LBS.

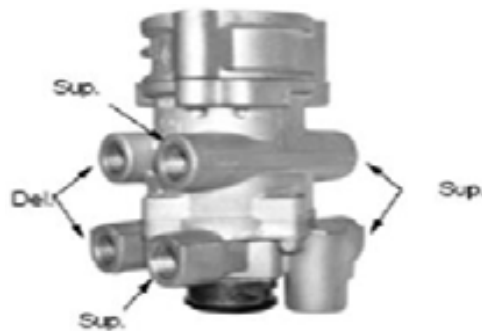

Part Number	All Ports
800632-N	3/8" PT

**E-12 & E-15 DUAL FOOT VALVE**  
PIC #102 - WEIGHT: 3 LBS.

**R & R  
ONLY**

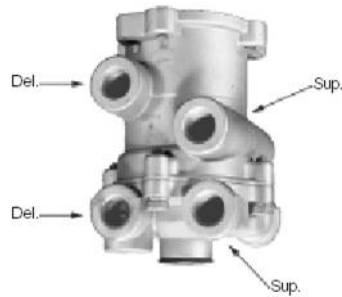

Part Number	All Ports
065313-N	3/8" PT

**E-14 DUAL FOOT VALVE**  
PIC #103 - WEIGHT: 3 LBS.

**R & R  
ONLY**

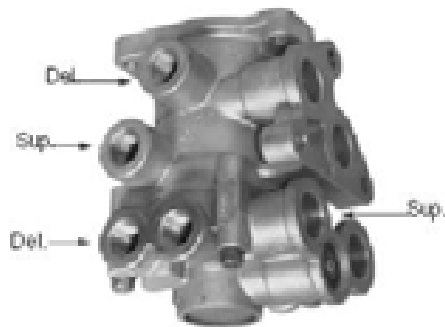

Part Number	All Ports	Comments
065314	3/8" PT	
065317	3/8" PT	Exhaust Port Threaded
065395	3/8" PT	Used with Manifold

**V  
A  
L  
V  
E  
S**

**PP-1 / RD-3 PUSH PULL CONTROL**  
PIC #110 - WEIGHT: 1 LB.

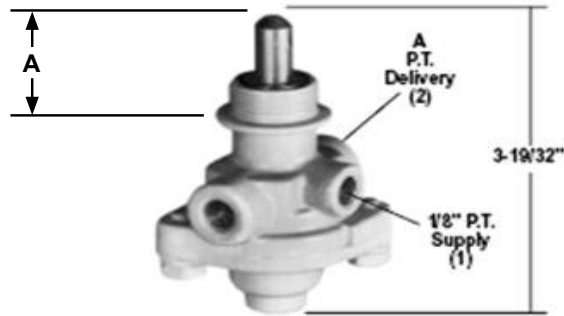

Part Number	Shaft Dia.	A	Delivery Ports	Automatic Release	Notes
275175-N	3/8"	1.12	1/8"	20 lbs.	
275176-N	3/8"	1.12	1/8"	40 lbs.	
101456	3/8"	1.62	1/8"	60 lbs.	
276569	3/8"	1.12	1/8"	30 lbs.	
278450	3/8"	1.12	1/8"	Non-Auto	No Spring
280995	3/8"	1.62	1/8"	40 lbs.	
281587	1/2"	1.12	1/8"	40 lbs.	Female Thrds in Shaft
282499	3/8"	1.62	1/4"	40 lbs.	
283827	3/8"	1.62	1/8"	20 lbs.	
283828-N	3/8"	1.12	1/8"	60 lbs.	
287417-N	3/8"	1.12	1/4"	30 lbs.	
287637	1/4"	1.12	1/8"	Non-Auto	No Spring
103757	Thrd	1.18	1/4"	40 lbs.	Male Thrds in Shaft 1/4-28
104240	3/8"	1.12	1/4"	60 lbs.	

RD-3 Part Number	Shaft Dia.	*	Delivery Ports	Exhaust	Notes
281481	3/8"	*	1/8"	1/8"	Push & Hold Emergency Release - Spring Brake

**PP-2 PUSH PULL CONTROL**  
PIC #111 - WEIGHT: 1 LB.



Part Number	Shaft Dia.	Auto Release	Notes
275250-N	3/8	40 lbs.	
280454	Thrds	40 lbs.	w/ 1/4" Female Thrds in Shaft

**R & R ONLY**

**PP-3 PUSH PULL CONTROL**  
PIC #112 - WEIGHT: 1 LB.

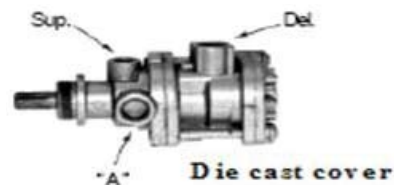

Part No.	Port A	Notes
279159-N	As Shown - None	
279787-N	As Shown - None	w/ 1/4" Female Thrds in Shaft
289477	1/8" PT	
289512	1/8" PT	w/ 1/4" Female Thrds in Shaft

ALL VALVES FURNISHED WITHOUT TREADLE OR BRACKETS

**PP-4 PUSH PULL CONTROL**  
PIC #113 - WEIGHT: 1 LB.

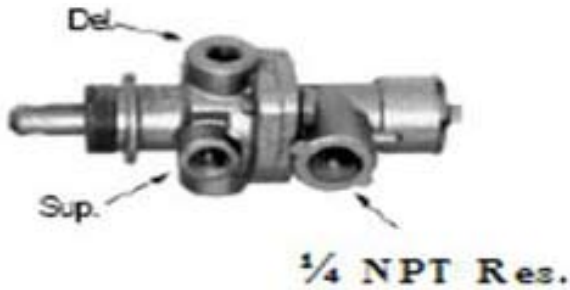

Part Number
278425

**PP-5 PUSH PULL CONTROL**  
PIC #114 - WEIGHT: 1 LB.

**R&R ONLY**



Part Number	Release	Pilot PSI
281946	40 lbs. Auto	18 PSI
284744	Manual	24 PSI

**PP-7 TRAILER SUPPLY VALVE**  
PIC #115 - WEIGHT: 1 LB.

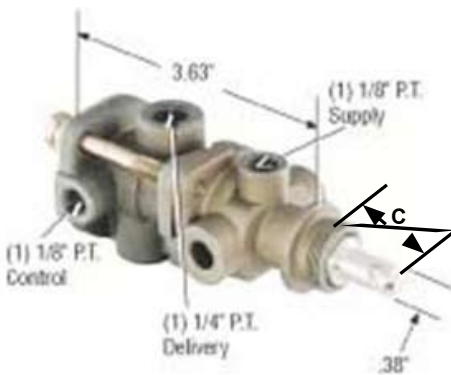

Part Number	C	Shaft Dia.	Exhaust Thrd.	Notes
286706-N	1 9/64"	3/8"	None	
287046	1 1/8"	1/2"	None	w/ 1/4 20 Fem. Thrds in Shaft
288241-N	1 9/64"	5/16"	1/4-18	
288242-N	1 1/8"	1/2"	None	w/ 1/4 20 Fem. Thrds & Sup Port 270 deg.
288644	1 9/64"	3/8"	None	
288721	1 9/64"	3/8"	1/4-18	
102192	1 9/64"	5/16"	1/4-18	Add. Del. Thrd 1/8-27

**PP-8 PUSH PULL CONTROL**  
PIC #116 - WEIGHT: 1 LB.

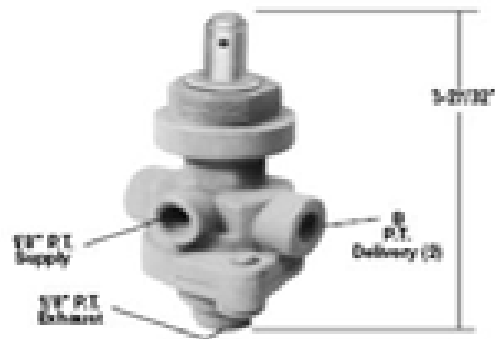

Part Number	Delivery Ports	Notes
287238-N	1/8"	-
287240	1/8"	w/ 1/4-20 Fem. Thrds in Shaft
287418	1/4"	-

**V  
A  
L  
V  
E  
S**

ALL VALVES FURNISHED WITHOUT TREADLE OR BRACKETS

**MV DASH MODULE**

PIC #118 - WEIGHT: 3 LBS.  
INTEGRATED CONTROL ASSEMBLY DESIGNED FOR CONTROL PANEL MOUNTING IN A TRUCK-TRACTOR. CONSISTS OF TWO PUSH-PULL VALVES AND A DUAL CIRCUIT SUPPLY VALVE.



**R & R ONLY**

Part Number	Reference Mid-No.
N4400	KN20615
N4400A	KN20612
N4400B	KN20611

**MV-2 CONTROL MODULE**

PIC #119 - WEIGHT: 3 LBS.  
ASSMEBL Y CONSISTS OF TWO PUSH-PULL VALVES AND A DUAL CIRCUIT SUPPLY VALVE.



Part Number	Mounting Holes
101437-N	1/4 No Thrd.
101890	1/4-20 Thrd.
102027	10-24 Thrd.

**MV-3 CONTROL MODULE**

PIC #120  
ASSEMBLY CONSISTS OF TWO PUSH-PULL VALVES AND A DUAL CIRCUIT SUPPLY VALVE. DESIGNED TO SUPERCEDE THE MV 2 VALVE

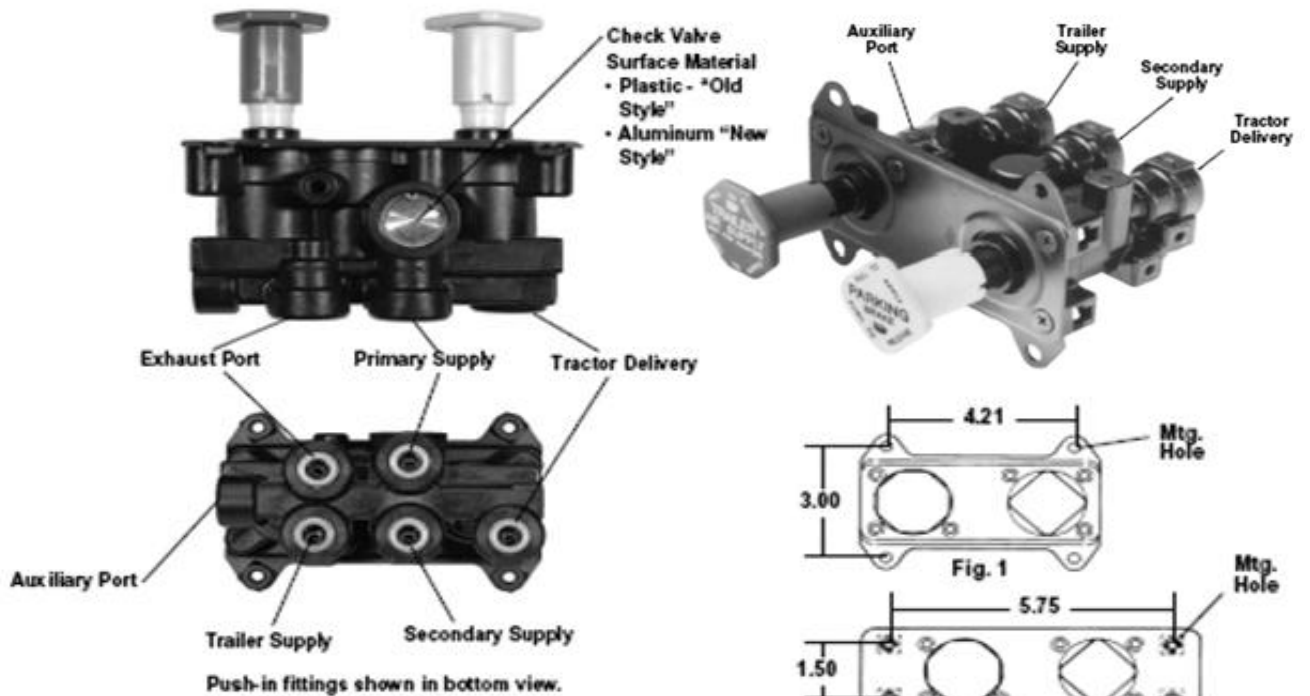

Part Number	Auxiliary Port	Exhaust Port	Mounting Plate	Mounting Hole
065156-N	--	--	Fig. 1	M6x1-6H
065157-N	--	--	Fig. 1	.28 Dia
065159	--	--	Fig. 2	M6x1-6H
065160	1/8 PT	--	Fig. 1	.28 Dia
065186	--	1/8 PT	Fig. 1	1/4-20
065187-N	--	1/8 PT	Fig. 1	1/4-20
065192	--	--	Fig. 3	1/4-20
065208	1/8 PT	--	Fig. 1	M6x1-6H

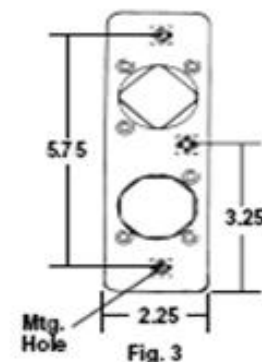

**V  
A  
L  
V  
E  
S**

VALVES

## PARK CONTROL TYPE DC VALVE

PIC #122

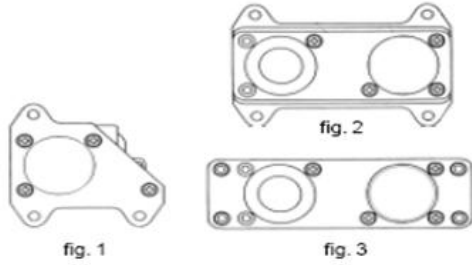
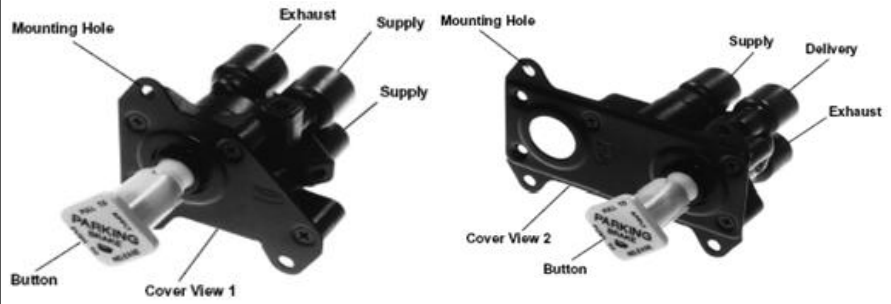

Part Number	Port Type	Mounting Hole	Mounting Plate
065643	3/8" OD Push to Connect	.27" Dia	Fig. 2
065661	3/8" OD Push to Connect	1/4"-20 Thread	Fig. 1
065690	3/8" OD Push to Connect	.27" Dia	Fig. 1
800034	1/4" - 18 NPT	.27" Dia	Fig. 2
800142	1/4" - 18 NPT	1/4"-20 Thread	Fig. 1
800260	1/4" - 18 NPT	1/4"-20 Thread	Fig. 3
800309			

## R-5 RELAY VALVE

PIC #123 - WEIGHT: 3 LBS.



Part Number	A	B
229200	None	1/2"
229467-N	1/2" PT	Plug

## R-6 RELAY VALVE

PIC #124 - WEIGHT: 3 LBS.

TOP MAY BE ROTATED

\* HAS SUPPLY PORT ON TOP COVER

\*\* ONLY VALVE WITH 10 PSI

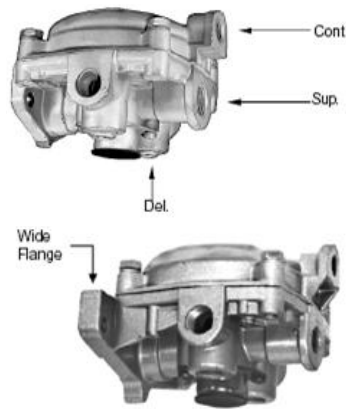

Part Number	PSI	Bracket Width	A Supply	B Supply
279180-N	2	2-1/2"	None	3/8"
279952-N	2	2-1/2"	3/4"	3/8"
280375-N	2	2-1/2"	None	1/2"
281182*	2	2-1/2"	None	3/8"
283033	2	2-1/2"	3/4"	1/2"
283940	2	5"	None	3/8"
280243**	10	2-1/2"	None	3/8"

## R-8 RELAY VALVE

PIC #125 - WEIGHT: 3 LBS.

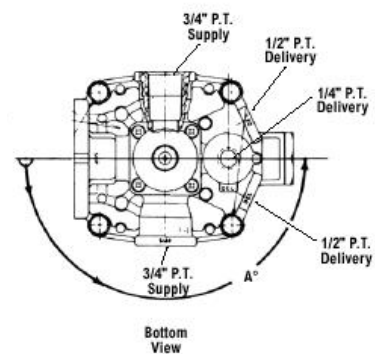

Part Number	Service Port Location (Degree)
287224-N	Rotate A Port 270 deg.
287260-N	Rotate A Port 180 deg.
286370-N	Rotate A Port 90 deg.

## R-8P RELAY VALVE

PIC #126 - WEIGHT: 3 LBS.

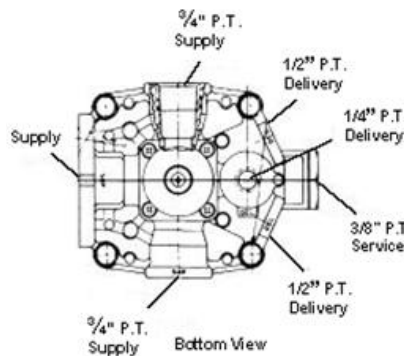
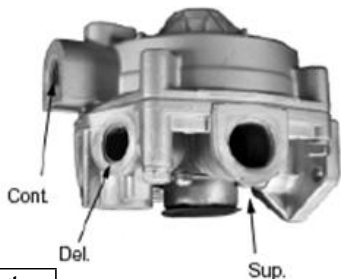

Part Number
287114-N

ALL VALVES FURNISHED WITHOUT TREADLE OR BRACKETS

**R-12 RELAY VALVE  
(VERTICAL DELIVERY PORTS)**  
PIC #127 - WEIGHT: 2 LBS.

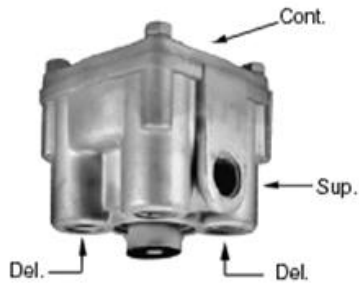

Part Number	Crack PSI	Delivery Ports
065104-N	4	(4) 3/8" PT
102626-N	4	(4) 1/2" PT
103912-N	7.5	(4) 1/2" PT
104561	5.5	(4) 3/8" PT

**R-12 RELAY VALVE  
(HORIZONTAL DELIVERY PORTS)**  
PIC #128 - WEIGHT: 2 LBS.

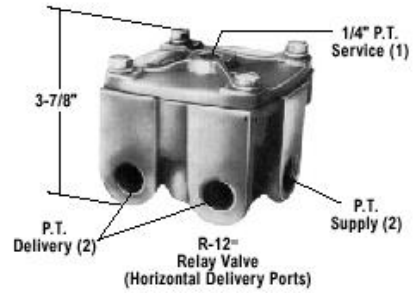

Part Number	Crack PSI	Supply Port
065125-N	5.5	(2) 1/2" PT
103009-N	4	(2) 3/4" PT
103195	10	(2) 3/4" PT
104165-N	7.5	(2) 3/4" PT

**R-12 RELAY VALVE  
(2-VERT 2-HORIZONTAL DEL PORTS)**  
PIC #129 - WEIGHT: 2 LBS.

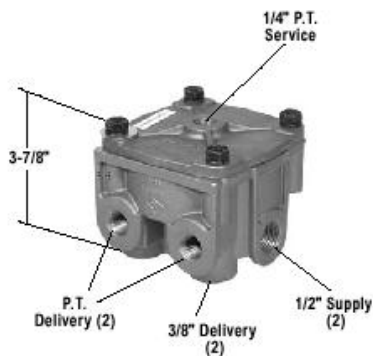

Part Number	Crack PSI	Delivery Port
065206-N	5.5	3/8" PT
800484	5.5	1/2" PT

**R-12 P PILOT RELAY VALVE**  
PIC #130



Part Number
109264-N

**R-12DC RELAY VALVE (2-HORIZONTAL DELIVERY PORTS)**  
PIC #131

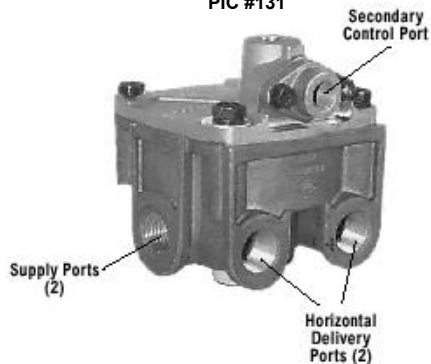

Part Number	Crack PSI	Supply Ports	Delivery Ports
800471-N	5.5	(2) 1/2" PT	(2) 1/2" PT

**R-12DC RELAY VALVE  
(2-HORIZ & 2-VERT DELIVERY PORTS)**  
PIC #132

**R & R ONLY**

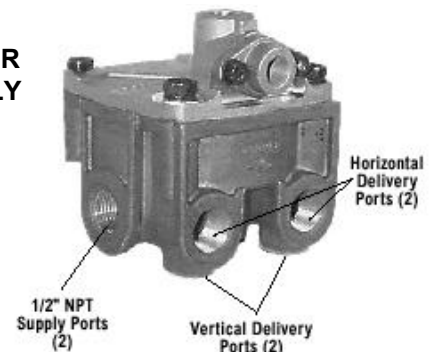

Part Number	Crack PSI	Horiz. Delivery Ports	Vert. Delivery Ports
800381	5.5	1/2" PT	3/8" PT

**R-12DC RELAY VALVE  
(4-VERTICAL DELIVERY PORTS)**  
PIC #133

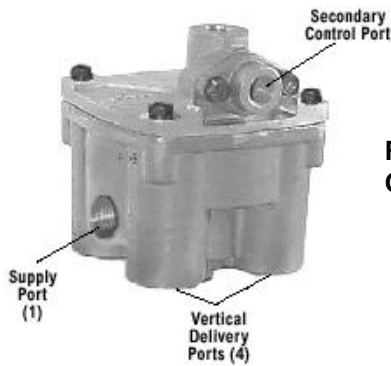

**R & R  
ONLY**

Part Number	Crack PSI	Vertical Ports
800477	4	(2) 1/2" PT

**R-14 RELAY VALVE  
(VERTICAL DELIVERY PORT)**  
PIC #134 - WEIGHT: 2 LBS.

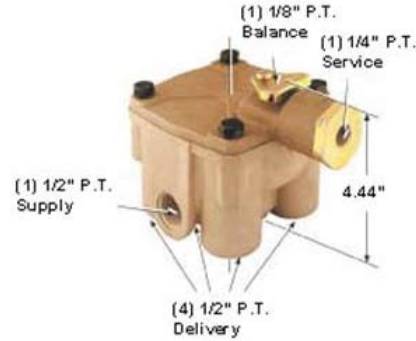

Part Number	Cracking PSI
103028-N	4
103833-N	7.5
106313	5.5

**R-14 RELAY VALVE  
(HORIZONTAL DELIVERY PORT)**  
PIC #135 - WEIGHT: 2 LBS.



Part Number	Cracking PSI
103010-N	4
103139	10
103294-N	5.5
103835-N	7.5
104345	5

**R-4 RELAY EMERGENCY VALVE**  
PIC #136 - WEIGHT: 4 LBS.

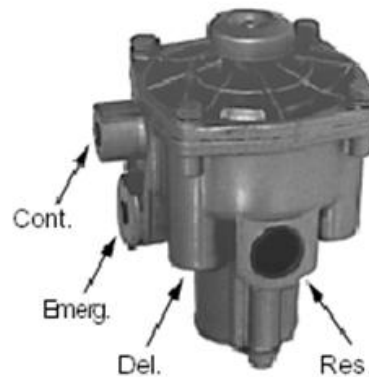

**R & R  
ONLY**

Part Number
277446

**R-7 MODULATING VALVE**

PIC #137 - WEIGHT: 3 LBS.  
COMMONLY FOUND ON TRUCKS AND BUSES WITH DUAL AIR BRAKE SYSTEMS.  
FUNCTION IS TO MODULATE THE SPRING BRAKES THROUGH APPLICATION OF THE FOOT BRAKE VALVE IN THE EVENT OF LOSS OF REAR AXLE SERVICE BRAKE PRESSURE.



Part Number	Spring Brake Release
103081-N	95 PSI
283932-N	85 PSI
286195	70 PSI

ALL VALVES FURNISHED WITHOUT TREADLE OR BRACKETS

**V  
A  
L  
V  
E  
S**

**TYPE 4 RELAY EMERGENCY VALVE**

PIC #138 - WEIGHT: 4 LBS.

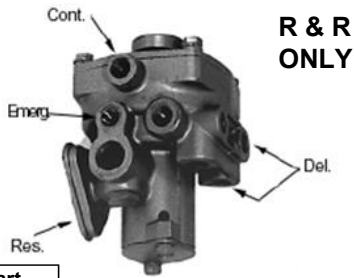

**R & R ONLY**

Part Number
228510

**RE-6 RELAY EMERGENCY VALVE**

PIC #139 - WEIGHT: 3 LBS.

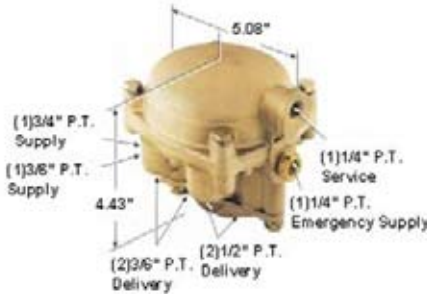

Part Number	A Delivery
281860-N	(2) 1/4"
281865-N	(2) 3/8"

**HR-1 HYDRAULIC RELAY**

PIC #140

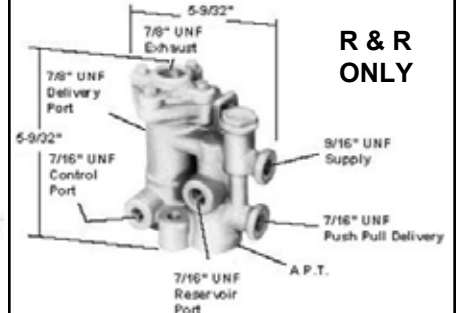

**R & R ONLY**

Part Number
065060

**MIDLAND RELAY VALVE**

PIC #142 - WEIGHT: 3 LBS.

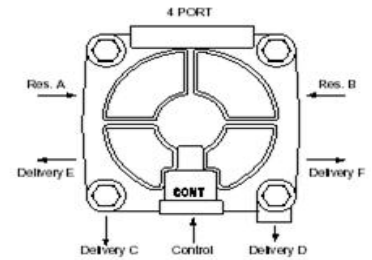
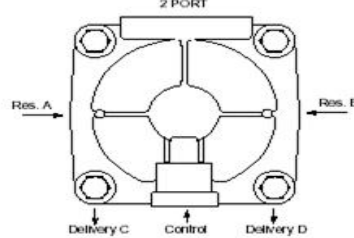
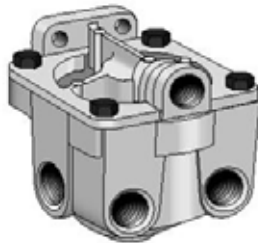

Part Number	Reservoir A	Reservoir B	Delivery C	Delivery D	Delivery E	Delivery F	Control	Crack PSI
N30096	1/2	1/2	3/8	3/8	-	-	3/8	4.6
N30096L	1/2	1/2	1/2	1/2	-	-	3/8	4.6
N30096N	1/2	1/2	3/8	3/8	3/8	3/8	3/8	7.0

**REF:**  
KN28060  
KN28061  
KN28080

**R & R ONLY**

**MIDLAND RELAY VALVE**

PIC #143 - WEIGHT: 3 LBS.

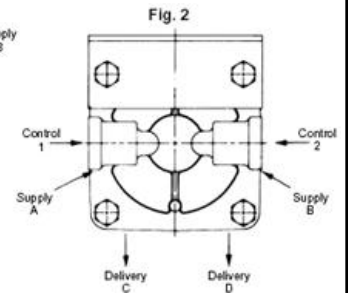
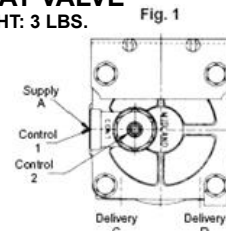
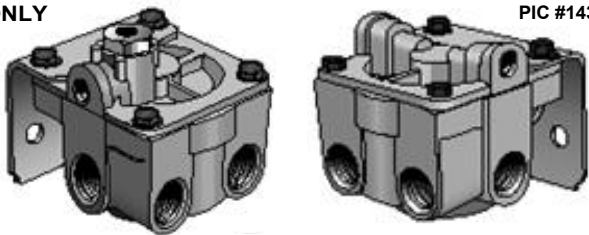

Part Number	Fig. Number	Supply A	Supply B	Delivery C	Delivery D	Ctrl. 1-From Park Cont. Valve	Ctrl. 2-From Rear Axle Serv. Brk.	Crack PSI
N30100	1	1/2	1/2	1/2	1/2	1/4	1/4	4.0
N30100AD	1	1/2	X	1/2	1/2	1/4	1/8	4.0
N30100AG	1	-	1/2	1/2	1/2	1/4	Not Drilled	4.0
N30100AR	2	1/2	1/2	1/2	1/2	1/4	1/4	4.0

**R & R ONLY**

**MIDLAND RELAY VALVE**

PIC #144 - WEIGHT: 4 LBS.

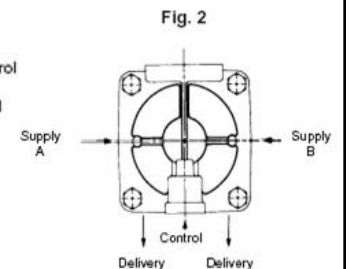
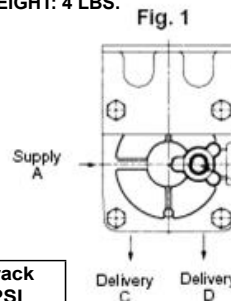
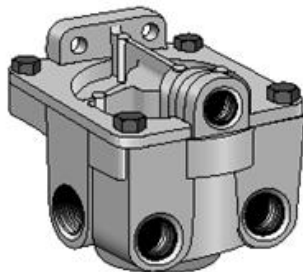

Part Number	Fig. Number	Control 1	Control 2	Supply A	Supply B	Delivery C	Delivery D	Crack PSI
N30106C	1	1/4	1/2	1/2	1/2	1/2	1/2	7.0
N30106D	2	3/8	-	1/2	1/2	1/2	1/2	7.0
N30106F	1	1/4	1/4	1/2	1/2	1/2	1/2	4.6

**MIDLAND-BERG RG-2 RELAY VALVE**  
PIC #145 - WEIGHT: 3 LBS.

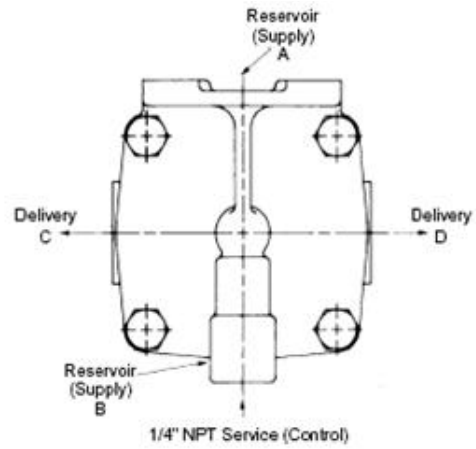
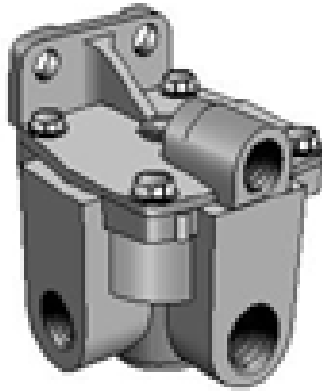

Part Number	Reservoir A	Reservoir B	Delivery C	Delivery D	Control Position
A78880-N	3/8	3/8	--	3/8	0 deg.
A78886-N	--	3/8	3/8	3/8	90 deg.
A78887-N	--	1/2	1/2	1/2	90 deg.
A78889-N	1/2	--	3/8	3/8	90 deg.
A86314-N	1/2	--	3/8	3/8	0 deg.

**MIDLAND FF-2 FULL FUNCTION VALVE**  
PIC #149 - WEIGHT: 3 LBS.

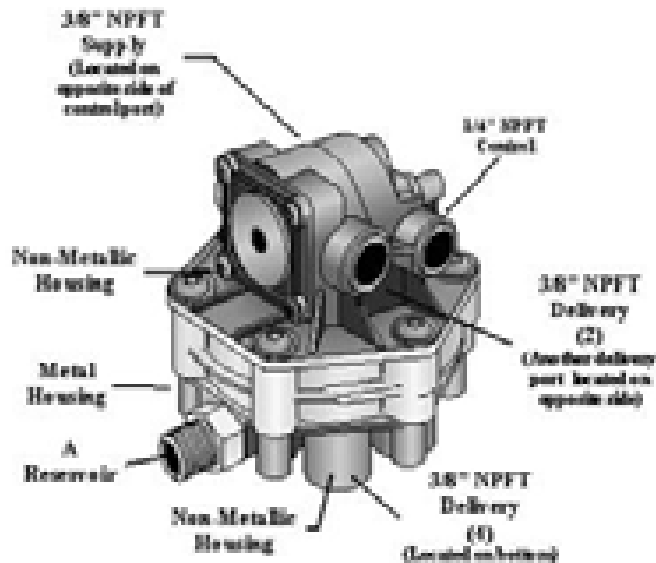

Part Number	A Reservoir	Crack PSI
N4304AC-N	(1) 3/4" PT	3
N4304AB-N	(1) 1/2" PT	3

V  
A  
L  
V  
E  
S

**MIDLAND-BERG MULTI-FUNCTION  
RELAY VALVE**

PIC #152 - WEIGHT: 2 LBS.

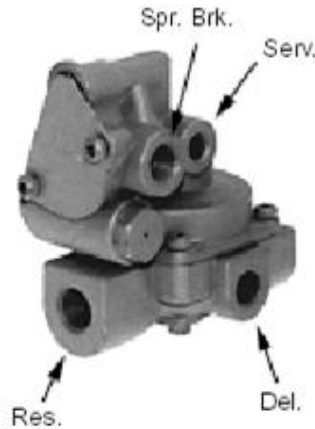

<b>Part Number</b>
12352-N

**SEALCO RELAY EMERGENCY  
VALVE**

PIC #156 - WEIGHT: 7 LBS.

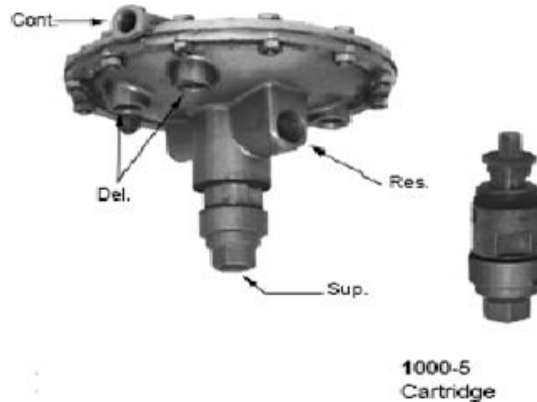

Part Number	Crack PSI
A1000	1.5

**MIDLAND/WAGNER EE  
EMERGENCY RELAY VALVE**

PIC #157 - WEIGHT: 3 LBS.

FOUR PORTS.

CRACKING PRESSURE 4.5 +/- 1 PSI.  
SUITABLE FOR PRE-121 TRAILERS,  
CONVERTER DOLLIES, OR EXEMPT TRAILERS.

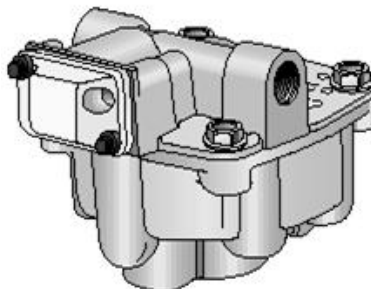

Part Number	Service Inlet	Emer. Inlet	Delivery	Auxiliary Reservoir	Reservoir
A71890-N	1/4	1/4	1/4	--	3/4
A71891-N	3/8	3/8	3/8	1/2	--

**SEALCO RELAY VALVE WITH RATIO**

PIC #161 - WEIGHT: 4 LBS.



Part Number	Crack PSI
110139-N	4.5

**SEALCO RATIO RELAY EMERGENCY VALVE**

PIC #162 - WEIGHT: 6 LBS.

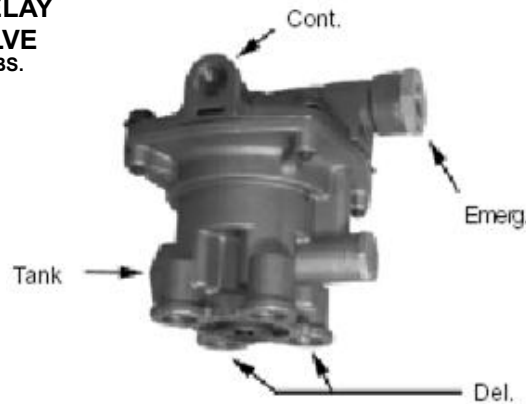

Part Number	A Emergency Supply	B Service Control	Ratio Feature
110200-N	(1) 1/4"PT	(2) 1/4" PT	Yes
110205-N	(1) 3/8"PT	(2) 3/8" PT	Yes
110460	(1) 1/4"PT	(2) 1/4" PT	No
110470	(1) 3/8"PT	(2) 3/8" PT	No

**WILLIAMS 3-WAY REGULATING VALVE**

PIC #173 - WEIGHT: 2 LBS.



Part Number	Output Range
WM90D	0-60 PSI

**V  
A  
L  
V  
E  
S**

**TW-1 DASH CONTROL VALVE**  
PIC #179 - WEIGHT: 1 LB.

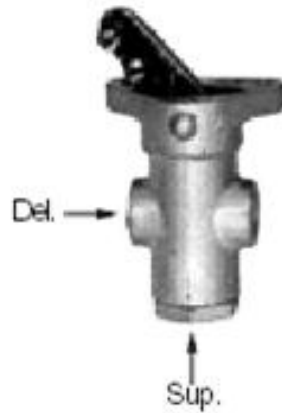

Part Number	Remarks
229608	Cable Operated
229617-N	Lever Operated

**TW-4 DASH CONTROL VALVE**  
PIC #182 - WEIGHT: 1 LB.



Part Number
276635

**V  
A  
L  
V  
E  
S**

## SEALCO SPRING BRAKE CONTROL VALVE

PIC #184 - WEIGHT: 4 LBS.

THE PROTECTED RESERVOIR IS USED ON TRAILERS WITH TWO RESERVOIRS & ALLOWS AIR TO BE SUPPLIED FROM SECOND RESERVOIR IN THE EVENT OF A SINGLE LEAKAGE FAILURE. COMPLIES WITH FMVSS 121 REGULATIONS INCLUDING DOCKET 90-3 EFFECTIVE OCT 8, 1992

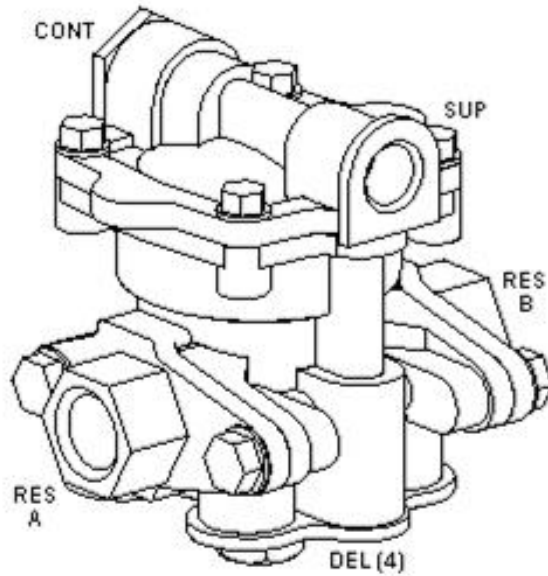

Part Number	Supply	Control	Resv. A	Resv. B	Delivery (4)	Cover Rotate
110170-N	3/8"	3/8"	1/2"	1/2"	3/8"	No
110171-N	3/8"	3/8"	1/2"	3/8"	3/8"	90 Deg
110191-N	3/8"	3/8"	3/8"	1/2"	3/8"	90 Deg
110310	3/8"	3/8"	3/8"	1/2"	3/8"	No
110315	3/8"	3/8"	1/2"	3/8"	3/8"	No

## SEALCO SPRING BRAKE CONTROL VALVE

PIC #185 - WEIGHT: 4 LBS.

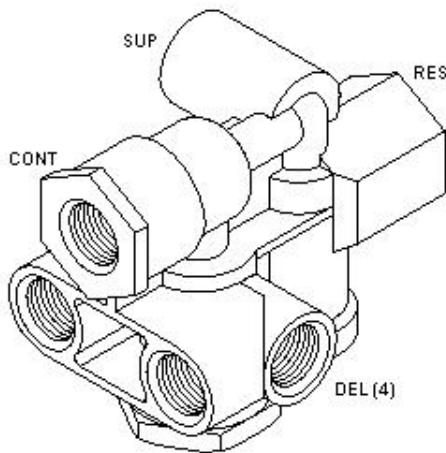

Part Number	Port Supply	Port Control	Port Reservoir	Port Delivery	Remarks
110500-N	3/8"	3/8"	1/2"	3/8"	None
110500-N	3/8"	3/8"	1/2"	3/8"	Del. Back Ports B Plugged
110500-N	3/8"	3/8"	1/2"	3/8"	Del. Back Ports A Plugged

## SEALCO SPRING BRAKE CONTROL VALVE

PIC #186 - WEIGHT: 4 LBS.

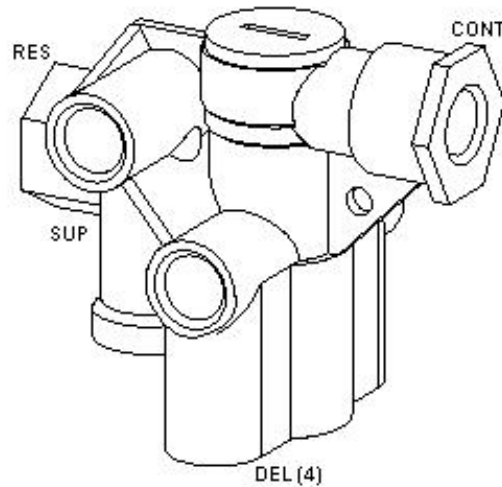

Part Number	Port Supply	Port Control	Port Reservoir	Port Delivery (4)
110700-N	3/8"	3/8"	1/2"	3/8"
110800-N	3/8"	3/8"	1/2"	3/8"

VALVES

**SR-1 SPRING BRAKE VALVE**  
PIC #187 - WEIGHT: 2 LBS.

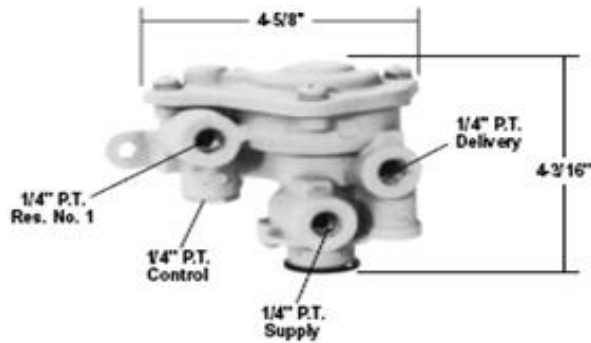

Part Number	Limiting Pressure	Reservoir Trip
286364-N	95 PSI	55 PSI
286365	60 PSI	30 PSI

**SR-2 TRAILER SPRING BRAKE VALVE**  
PIC #188 - WEIGHT: 3 LBS.

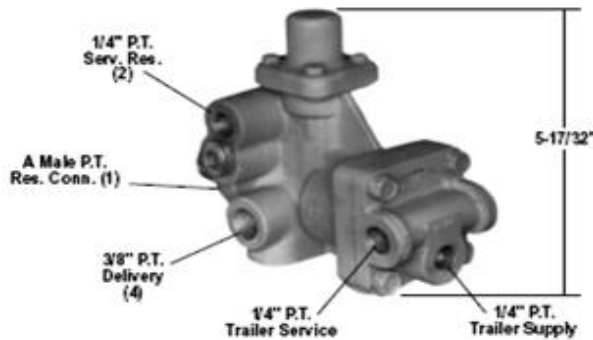

Part Number	A
287376-N	3/4"
288497-N	1/2"

**SR-4 TRAILER SPRING BRAKE VALVE**  
PIC #189 - WEIGHT: 3 LBS.

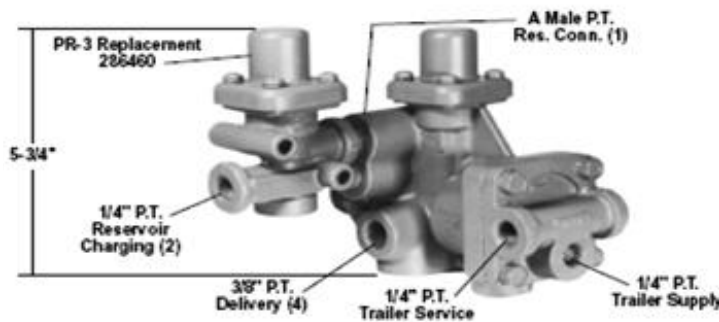

Part Number	Mounting Port
101112-N	3/4"
101622-N	1/2"

**IMPORTANT NOTE:** Due to different operational characteristics, the SR-4 **SHOULD NOT** be interchanged with SR-2 under any circumstances.

**SR-5 TRAILER SPRING BRAKE VALVE**  
PIC #191



Part Number	Reservoir	Anti-Compounding
065437-N	3/4"	Yes
065439-N	1/2"	No

## TP-3 TRACTOR PROTECTION VALVE

PIC #194 - WEIGHT: 2 LBS.



Part Number	A Trailer Emerg.	B Trailer Service
279000-N	1/2" PT	1/2" PT
279692	3/8" PT	3/8" PT

## TP-5 TRACTOR PROTECTION VALVE

PIC #196 - WEIGHT: 2 LBS.



Part Number
288605-N

\* Formerly VM-2

VALVES

**QR-1 QUICK RELEASE VALVE**  
PIC #200 - WEIGHT: 1 LB.



Part Number	A Supply	B Delivery	C Exhaust	Crack PSI
101487-N	(1) 1/2" PT	(2) 3/8" PT	No Thread	--
229813-N	(1) 3/8" PT	(2) 1/4" PT	No Thread	1
229844-N	(1) 1/2" PT	(2) 1/4" PT	No Thread	1
229859-N	(1) 3/8" PT	(2) 3/8" PT	No Thread	1
229860-N	(1) 1/2" PT	(2) 3/8" PT	No Thread	1
278483	(1) 1/2" PT	(2) 3/8" PT	No Thread	5-8
281024	(1) 1/4" PT	(2) 1/4" PT	No Thread	1
288251	(1) 3/8" PT	(2) 3/8" PT	(1) 3/8" PT	1

**QR-1C QUICK RELEASE**  
PIC #202 - WEIGHT: 1 LB.

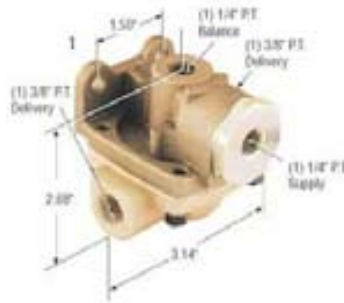

Part Number	A Delivery
289182-N	(2) 1/4" PT
289714-N	(2) 3/8" PT

**LQ-2 LIMITING QUICK RELEASE VALVE**  
PIC #203 - WEIGHT: 1 LB.

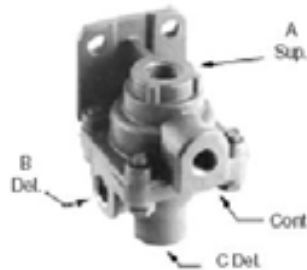

Part Number	A	B	C
223821	3/8	3/8	3/8
225433	1/4	1/2	3/8
229505-N	3/8	3/8	--
229507	1/2	1/4	--
229509	3/8	1/4	--

**LQ-4 FRONT AXLE RATIO VALVE** PIC #205 - WEIGHT: 1 LB.

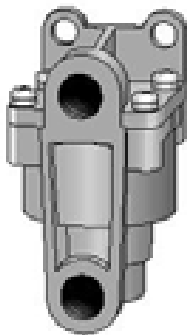

Part Number	Equalizing PSI
101311	70
289144-N	60
289148-N	65

**BP-R1 PROPORTIONING RELAY VALVE**

PIC #208 - WEIGHT: 3 LBS.



Part Number	Crack PSI
065145-N	4.0
065146-N	5.5

**V  
A  
L  
V  
E  
S**

**TR-3 INVERSION VALVE**  
PIC #212 - WEIGHT: 1 LB.



Part Number	Descending Pressure	Ascending Pressure
101450	25 PSI	40 PSI
*280758-N	45 PSI	60 PSI
281318-N	35 PSI	70 PSI
281459-N	25 PSI	40 PSI
281927	45 PSI	65 PSI
284146	50 PSI	60 PSI
288586	55 PSI	90 PSI
289288	42 PSI	52 PSI

\* Basic Exchange Valve

**PR-1 PRESSURE REDUCING VALVE**

PIC #214 - WEIGHT: 1 LB.



A=Supply  
B=Delivery

Part Number	Delivery Pressure
*277144-N	80 PSI
277215-N	30 PSI
278426	65 PSI
282811	60 PSI

\* Basic Exchange Valve

**PR-2 PRESSURE PROTECTION VALVE**

PIC #215 - WEIGHT: 1 LB.

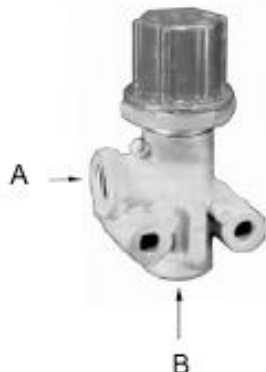

A=Delivery  
B=Supply

Part Number	Closing Pressure
*277147-N	65 PSI
277148-N	85 PSI
277226	60 PSI
277227-N	75 PSI

**PR-3 / PR-4 PRESSURE PROTECTION VALVE**

PIC #216 - WEIGHT: 1 LB.

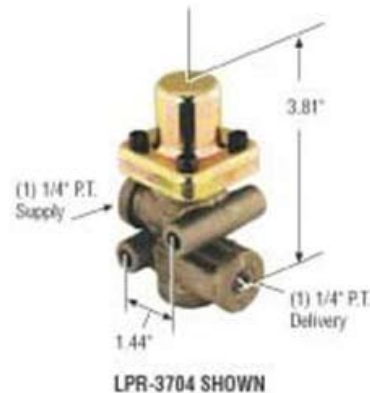

LPR-3704 SHOWN

Part Number	Closing Pressure	Supply	Delivery
286460	--	1/4"	1/4"
*286500-N	85 PSI	1/4"	1/4"
288323-N	70 PSI	1/4"	1/4"

\* Basic Exchange  
#286460 is a PR-3

**MIDLAND PRESSURE PROTECTION VALVE**  
PIC #217 - WEIGHT: 1 LB.

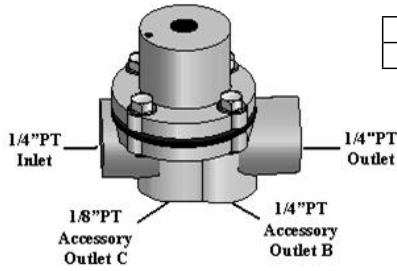

Part Number
N15759E-N

**DV-2 AUTOMATIC RESERVOIR DRAIN VALVE**  
PIC #220



Part Number	Strainer Port
281923-N	A
281924	B

**DOUBLE CHECK VALVES**

PIC #222



DC-1  
217698

PIC #223



DC-4  
278614 3/8  
278615 1/4

PIC #224



DC-4

Pipe Thread Dimensions

Part Number	A	B	C	D
278595	1/2"	1/4"	1/4"	1/4"
278596	1/2"	1/4"	3/8"	1/4"
278597	3/8"	1/4"	1/4"	1/4"
278598-N	3/8"	3/8"	3/8"	1/4"
280809	3/8"	3/8"	3/8"	3/8"
287180	3/8"	1/4"	3/8"	1/4"

**CUMMINS FUEL SOLENOID**  
PIC #225 - WEIGHT: 1 LB.



Part Number	Voltage
6997312	12 Volts
6997324	24 Volts

\* Basic Exchange Valve

# STOP LIGHT SWITCHES

## SL-5 STOP LIGHT SWITCH PIC #228 - WEIGHT: 1 LB.



Part Number	Terminal Size & Thrd.
13250-N	
286392	8-32
286404	10-32

## LP-3 LOW PRESSURE INDICATOR PIC #230 - WEIGHT: 1 LB.

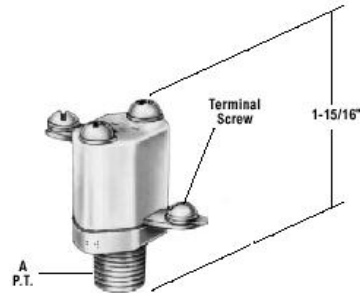

Part Number	Contacts Close (PSI)	Terminals (Shown)
228750-N	60 +/-6	2
279416-N	60 +/-6	1

## ST-1 / ST-3 / ST-4 PIC #231 - WEIGHT: 1 LB.



Part Number	A Port	Pressure Setting
205105-N	1/4" PT	150 PSI

\* Adjustable



Part Number	A Port	Pressure Setting
284142-N	1/4" PT	150 PSI
284143-N	3/8" PT	150 PSI

\* Non-adjustable

Part Number	A Port	Pressure Setting
800350-150-N	1/4" PT	150 PSI
800350-175-N	1/4" PT	175 PSI
800350-200-N	1/4" PT	200 PSI

\* Non-adjustable

## SC-1 / SC-3 CHECK VALVES PIC #232 - WEIGHT: 1 LB.



Part Number		REF.
227870-N	3/8"	KN23010
227871-N	1/2"	KN23000

VALVES

ALL VALVES FURNISHED WITHOUT TREADLE OR BRACKETS

**SEALCO DASH VALVE**

PIC #235 - WEIGHT: 1 LB.

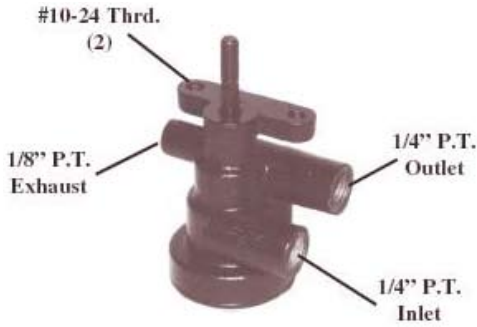

Part Number
99600-N

**FULLER PUSH PULL VALVE**

PIC #236



Part Number
A3546-N

**NEWAY LEVELING VALVE**

PIC #237

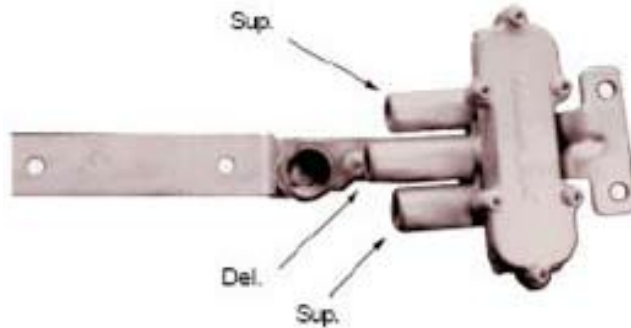

Part Number
90054007-N

**FULLER AIR VALVE**

PIC #238 - WEIGHT: 1 LB.



Part Number
A4490-N

**FULLER SLAVE VALVE**

PIC #239 - WEIGHT: 1 LB.

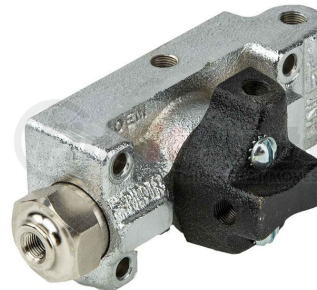

Part Number
A4688-N

**FULLER RANGE VALVE**

PIC #240 - WEIGHT: 1 LB.



Part Number
A4900-N

**FULLER RANGE VALVE**

PIC #241 - WEIGHT: 1 LB.



Part Number
A5010-N

**V  
A  
L  
V  
E  
S**

**FULLER RANGE VALVE**  
PIC #242 - WEIGHT: 1 LB.



Part Number
A5015-N

**FULLER RANGE VALVE**  
PIC #243- WEIGHT: 1 LB.



Part Number
A6909-N

**FULLER RANGE VALVE**  
PIC #244- WEIGHT: 1 LB.



Part Number
A6913-N

**FULLER RANGE VALVE**  
PIC #245- WEIGHT: 1 LB.



Part Number
A6915-N

**FULLER RANGE VALVE**  
PIC #246 - WEIGHT: 1 LB.



Part Number
A6918-N

**WILLIAMS PRESSURE PROTECTION**

PIC #247



Part Number
WM778-N

V  
A  
L  
V  
E  
S

ALL VALVES FURNISHED WITHOUT TREADLE OR BRACKETS

**MEDIUM DUTY**

**TRUCK & BUS**

**APPLICATIONS**

# PRIOR AUTOMOTIVE PRODUCTS, LLC

## LIMITED WARRANTY POLICY VACUUM - HYDRAULIC POWER BRAKES

Prior Brake Products warranties to the original purchaser of its products that those products will be free of defective materials and workmanship. This does not include defects caused by neglect, improper installation, maintenance or service.

**Warranty Duration:** All new and remanufactured products for automotive passenger cars and light duty trucks are warranted to the owner of the vehicle for which the unit was purchased for a period of 12 months from the original purchase date or 15,000 miles after installation, whichever comes first.

To make a claim under this warranty it must be returned to the factory or the store where purchased with proof of purchase and paperwork or warranty tag explaining the reason for the : The paperwork or warranty tag must be completely filled out by the installer or the original pur

During the above warranty period, the unit will either be repaired or replaced, or credit issued when the unit is returned.

Prior Brake Products liability does not include Labor Charges or Incidental or Consequential Damage.

**Warranty Disclaimer:** This warranty is in lieu of and excludes all other warranties, expressed or implied, arising by operation of law or otherwise, including any implied warranty or merchantability or fitness for a particular purpose, and in no event will Prior Brake Products be liable for incidental or consequential damage.

This warranty has been drafted to comply with Federal rules issued under the Magnuson-Moss Warranty Act applicable to products manufactured after December 31, 1976.

Some states do not allow the exclusion or limitation of implied warranties, incidental or consequential damages, so the above limitations or exclusions may not apply to you.

**Legal Remedies:** This warranty gives you specific legal rights, and you may also have other rights that vary from state to state.

PVR/WAR 9-94

**BLUE BIRD  
BUS**

YEAR	VEHICLE - MODEL	HYD VAC or P.S. & M.C.	Wt. Lbs	POWER SEC. w/o M.C.	Wt. Lbs	PEDAL ROD CODE	PICT. NO.
2006-96	T C 2000						
	Hydromax (casting # 2772114)..... Elec. Motor - stud type - 2771320			<b>3700625</b>	7 5		9 10
1995-89	Hydromax (casting # 2771424)..... Elec. Motor - w/wire & connector - 2771420			<b>3700380</b>	7 5		9 10

**CHEVROLET TRUCK  
MEDIUM DUTY**

VARIOUS MODELS							
2020-97	All						
	Hydromax (casting # 2772114).....			<b>3700625</b>	7		9
	2006-03 Elec. Motor - 2 wire plug - 2772729				5		10
	2002-97 Elec. Motor - stud type - 2771320				5		10
1996-90	Delco Hy-Power - Casting # 18014765						
	w/ 7" Pedal Rod.....			<b>7700439</b>	18		12
	w/ 9" Pedal Rod.....			<b>7700556</b>	18		12
	Elec. Motor - with wire & pigtail - 6700974						13
1989-88	Delco Hy-Power - casting # 2623435						
	w/ 7" Pedal Rod.....			<b>7700439</b>	18		12
	Elec. Motor - with wire & pigtail - 6700974						13
	Elec. Motor - with female plug - 6700975						13
1987-85	Delco Hy-Power - casting # 2623435						
	w/ 7" Pedal Rod.....			<b>7700439</b>	18		12
	Elec. Motor - with wire & pigtail - 6700974						13
	Elec. Motor - with female plug - 6700975						13
	Delco Dual Power (works w/ Vacuum & Power Steering Pump) :						
	Hydraulic Section w/ Casting						
	No. 2623501.....			<b>7700435</b>	6		14
Vacuum Section w/ 5 1/4" Pedal Rod.....			<b>7700437</b>	6		14	
1984	w/ 7" Pedal Rod.....			<b>7700436</b>	6		14
	Delco Hy-Power - casting # 2623435						
	w/ 7" Pedal Rod.....			<b>7700439</b>	18		12
	Elec. Motor - with wire & pigtail - 6700974						13
	Elec. Motor - with female plug - 6700975						13
	Delco Dual Power (works w/ Vacuum & Power Steering Pump) :						
	Hydraulic Section w/ Casting						
No. 2623501.....			<b>7700435</b>	6		14	
Vacuum Section w/ 5 1/4" Pedal Rod.....			<b>7700437</b>	6		14	
w/ 7" Pedal Rod.....			<b>7700436</b>	6		14	
1983-77	50 Series w/ dual system Hydro-vac: (two units req'd).....	<b>2510027</b>	24				34
	50 - 60 - 70 Series w/ Single Dia. Unit.....	<b>2503139</b>	24				34
	50 Series w/ dual system Hydro-vac: (two units req'd).....	<b>2510027</b>	24				34
1983-77	Delco Dual Power (works w/ Vacuum & Power Steering Pump) :						
	Hydraulic Section w/ Casting						
	No. 2623501.....			<b>7700435</b>	6		14
	Vacuum Section w/ 5 1/4" Pedal Rod.....			<b>7700437</b>	6		14
w/ 7" Pedal Rod.....			<b>7700436</b>	6		14	

**M  
E  
D  
I  
U  
M  
D  
U  
T  
Y  
A  
P  
P  
L  
I  
C  
A  
T  
I  
O  
N  
S**

# MEDIUM DUTY TRUCK APPLICATIONS



**MEDIUM DUTY APPLICATIONS**

YEAR	CHEVROLET TRUCK CONT'D VEHICLE - MODEL	HYD VAC or P.S. & M.C.	Wt. Lbs	POWER SEC. w/o M.C.	Wt. Lbs	PEDAL ROD CODE	PICT. NO.
1983-77	50 - 60 - 70 Series w/ Single Dia. Unit.....	2503139	24				34
	60 - 70 - 80 Series w/ Tandem Dia. Unit.....	2503123	38				35
1976-74	Delco Dual Power (works w/ Vacuum & Power Steering Pump) : Hydraulic Section w/ Casting No. 2623501.....			7700435	6		14
	Vacuum Section w/ 5 1/4" Pedal Rod.....			7700437	6		14
	w/ 7" Pedal Rod.....			7700436	6		14
	50 - 60 - 70 Series w/ Single Dia. Unit.....	2503139	24				34
	60 - 70 - 80 Series w/ Tandem Dia. Unit.....	2503123	38				35
1973-70	50 - 60 - 70 Series w/ Single Dia. Unit.....	2503139	24				34
	60 - 70 - 80 Series w/ Tandem Dia. Unit.....	2503123	38				35
1969	50 - 60 - 70 Series w/ Single Dia. Unit.....	2503139	24				34
	60 - 70 - 80 Series w/ Tandem Dia. Unit.....	2503123	38				35
	SS 400 - 500, SE 500 (Midland frame mount).....	C4090	29				25
	Bus SS 400 - 500, SE 500 - 600 (firewall mount).....	C4089	31	C4084B	20		8
1968	CE, CS, SS, 40 - 50 - 60 Series (firewall mount)<9>.....	C4074	23	C4037L	16		7
	50 - 60 - 70 Series w/ Single Dia. Unit.....	2503139	24				34
	60 - 70 - 80 Series w/ Tandem Dia. Unit.....	2503123	38				35
	SS 400 - 500, SE 500 (Midland frame mount).....	C4090	29				25
	Bus SS 400 - 500, SE 500 - 600 (firewall mount).....	C4089	31	C4084B	20		8
	CE, CS, SS, 40 - 50 - 60 Series (firewall mount)<9>.....	C4074	23	C4037L	16		7
1967	80 Series w/ 36,000 lb. GVW (Midland Frame Mount).....	C4058	35				30
	ME 600 (Midland Frame Mount).....	C4057	38				30
	CE, CS, SS, 40 - 50 - 60 Series (firewall mount)<9>.....	C4074	23	C4037L	16		7
	50 - 60 Series (Air Over Hydraulic).....	2504183	16				47
	50 - 60 - 70 Series w/ Single Dia. Unit.....	2503139	24				34
	60 - 70 - 80 Series w/ Tandem Dia. Unit.....	2503123	38				35
1966	50 - 60 Series.....	2503151	24				34
	80 Series w/ 36,000 lb. GVW (Midland Frame Mount).....	C4058	35				30
	ME 600 (Midland Frame Mount).....	C4057	38				30
	50 - 60 Series (Air Over Hydraulic).....	2504183	16				47
	50 - 60 - 70 Series w/ Single Dia. Unit.....	2503139	24				34
	60 - 70 - 80 Series w/ Tandem Dia. Unit.....	2503123	38				35
	50 - 60 Series.....	2503151	24				34
	1 1/2 Ton Over 8800 to 16,000 lb. GVW - Field Inst.....	2500397	12				43
	8403, 8503, 8703, 10403, 10412, 10503, 10703 w/ Tandem Axle.....	374750	25				46
60 Series, Tandem (Air Over Hydraulic).....	2504184	16				47	
1965	50 - 60 - 70 Series w/ Single Dia. Unit.....	2503139	24				34
	60 - 70 - 80 Series w/ Tandem Dia. Unit.....	2503123	38				35
	50 - 60 Series.....	2503151	24				34
	1 1/2 Ton Over 8800 to 16,000 lb. GVW - Field Inst.....	2500397	12				43
	8403, 8503, 8703, 10403, 10412,						

YEAR	CHEVROLET TRUCK CONT'D VEHICLE - MODEL	HYD VAC or P.S. & M.C.	Wt. Lbs	POWER SEC. w/o M.C.	Wt. Lbs	PEDAL ROD CODE	PICT. NO.
1965	10503, 10703 w/ Tandem Axle.....	374750	25				46
	60 Series (Air Over Hydraulic).....	2502061	17				47
	80 Series (Air Over Hydraulic).....	2502062	17				47
	60 - 80 Series w/ Tandem Dia. Booster w/ Gravity Flow Line From Master Cyl.....	2503123	38				35
	60 H.D. Series w/ Single Dia. Booster w/ Gravity Flow Line From Master Cyl.....	2503139	24				34
	50 - 60 Series w/ 11" Diameter Vacuum Chamber.....	2501847	20				34
1964	1 1/2 Ton Over 8800 to 16,000 lb. GVW - Field Inst.....	2500397	12				43
	8403, 8503, 8703, 10403, 10412, 10503, 10703 w/ Tandem Axle.....	374750	25				46
	60 Series (Air Over Hydraulic).....	2502061	17				47
	80 Series (Air Over Hydraulic).....	2502062	17				47
	50 - 60 Series w/ 11" Diameter Vacuum Chamber.....	2501847	20				34
	60 - 80 Series w/ Tandem Dia. Booster w/ Gravity Flow Line From Master Cyl.....	2503123	38				35
	60 H.D. Series w/ Single Dia. Booster w/ Gravity Flow Line From Master Cyl.....	2503139	24				34
	40 - 50 - 60 Series (Exc. H.D. Booster).....	374000	13				27
1963	1 1/2 Ton Over 8800 to 16,000 lb. GVW - Field Inst.....	2500397	12				43
	8403, 8503, 8703, 10403, 10412, 10503, 10703 w/ Tandem Axle.....	374750	25				46
	60 Series (Air Over Hydraulic).....	2502061	17				47
	80 Series (Air Over Hydraulic).....	2502062	17				47
	50 - 60 Series w/ 11" Diameter Vacuum Chamber	2501847	20				34
	60 - 80 Series w/ Tandem Dia. Booster w/ Gravity Flow Line From Master Cyl.....	2503123	38				35
	60 H.D. Series w/ Single Dia. Booster w/ Gravity Flow Line From Master Cyl.....	2503139	24				34
	40 - 50 - 60 Series (Exc. H.D. Booster).....	374000	13				27
	4 - 5 - 6 - 8 - 10 (Exc. Tandem) Air Over Hydraulic.....	375756	14				47
1962	50 - 60 Series w/ 11" Diameter Vacuum Chamber	2501847	20				34
	60 - 80 Series w/ Tandem Dia. Booster w/ Gravity Flow Line From Master Cyl.....	2503123	38				35
	60 H.D. Series w/ Single Dia. Booster w/ Gravity Flow Line From Master Cyl.....	2503139	24				34
	40 - 50 - 60 Series (Exc. H.D. Booster).....	374000	13				27
	4 - 5 - 6 - 8 - 10 (Exc. Tandem) Air Over Hydraulic.....	375756	14				47
	40 - 50 Series (Exc. H.D. Booster).....	2500660	14				39
	70 Series (Midland Frame Mount).....	C4012	21				23
	80 Series (Midland Frame Mount).....	C4013	38				28
	70 - 80 Series Tandem Axle Multi Pak.....	2500087	15				47
	Multi Pak.....	2500086	15				47
	(Used w/ C4103).....	C4007	17				20
1962	1 1/2 Ton Over 8800 to 16,000 lb. GVW - Field Inst.....	2500397	12				43
	8403, 8503, 8703, 10403, 10412, 10503, 10703 w/ Tandem Axle.....	374750	25				46

**M  
E  
D  
I  
U  
M  
D  
U  
T  
Y  
A  
P  
P  
L  
I  
C  
A  
T  
I  
O  
N  
S**

# MEDIUM DUTY TRUCK APPLICATIONS



MEDIUM DUTY APPLICATIONS

YEAR	CHEVROLET TRUCK CONT'D VEHICLE - MODEL	HYD VAC or P.S. & M.C.	Wt. Lbs	POWER SEC. w/o M.C.	Wt. Lbs	PEDAL ROD CODE	PICT. NO.
1961-60	1 1/2 Ton Over 8800 to 16,000 lb. GVW - Field Inst.....	2500397	12				43
	8403, 8503, 8703, 10403, 10412, 10503, 10703 w/ Tandem Axle.....	374750	25				46
	40 - 50 - 60 Series (Exc. H.D. Booster).....	374000	13				27
	4 - 5 - 6 - 8 - 10 (Exc. Tandem) Air Over Hydraulic.....	375756	14				47
	40 - 50 Series (Exc. H.D. Booster).....	2500660	14				39
	70 Series (Midland Frame Mount).....	C4012	21				23
	80 Series (Midland Frame Mount).....	C4013	38				28
	70 - 80 Series Tandem Axle (used w/ C4103)	C4007	17				20
	60 - 70 - 80 Series Tandem - Multi Pak.....	2500087	15				47
	60 - 70 Series Exc. Tandem - Multi Pak.....	2500086	15				47
	4 - 10 Series Tandem, Air Over Hydraulic.....	375901	14				47
	Various Models, Air Over Hydraulic (Midland).....	N4105D	19				49
	1959-57	40 - 50 - 60 Series (Exc. H.D. Booster).....	374000	13			
4 - 5 - 6 - 8 - 10 (Exc. Tandem) Air Over Hydraulic.....		375756	14				47
Various Models, Air Over Hydraulic (Midland).....		N4105D	19				49
2 & 2 1/2 Ton School Bus (w/ 20,000 lb. & Up GVW).....		374980	22				45
1 1/2 Ton Over 8800 to 16,000 lb. GVW - Field Inst.....		2500397	12				43
8403, 8503, 8703, 10403, 10412, 10503, 10703 w/ Tandem Axle.....		374750	25				46
1956	8403, 8503, 8703, 10403, 10412, 10503, 10703 w/ Tandem Axle.....	374750	25				46
	1 1/2 Ton Over 8800 to 16,000 lb. GVW - Field Inst.....	2500397	12				43
	40 - 50 - 60 Series (Exc. H.D. Booster).....	374000	13				27
	4 - 5 - 6 - 8 - 10 (Exc. Tandem) Air Over Hydraulic.....	375756	14				47
	Various Models, Air Over Hydraulic (Midland).....	N4105D	19				49
	2 & 2 1/2 Ton School Bus (w/ 20,000 lb. & Up GVW).....	374980	22				45
	7000 - 9000 Series.....	376500	9				38
	1955	1 1/2 Ton Over 8800 to 16,000 lb. GVW - Field Inst.....	2500397	12			
40 - 50 - 60 Series (Exc. H.D. Booster).....		374000	13				27
4 - 5 - 6 - 8 - 10 (Exc. Tandem) Air Over Hydraulic.....		375756	14				47
Various Models, Air Over Hydraulic (Midland).....		N4105D	19				49
2 & 2 1/2 Ton School Bus (w/ 20,000 lb. & Up GVW).....		374980	22				45
7000 - 9000 Series.....		376500	9				38
1954-53	1 1/2 Ton Over 8800 to 16,000 lb. GVW - Field Inst.....	2500397	12				43
	4 - 5 - 6 - 8 - 10 (Exc. Tandem) Air Over Hydraulic.....	375756	14				47
	Various Models, Air Over Hydraulic (Midland).....	N4105D	19				49
	7000 - 9000 Series.....	376500	9				38

YEAR	CHEVROLET TRUCK CONT'D VEHICLE - MODEL	HYD VAC or P.S. & M.C.	Wt. Lbs	POWER SEC. w/o M.C.	Wt. Lbs	PEDAL ROD CODE	PICT. NO.
1954-53	7000 - 9000 Series.....	376500	9				38
1952	1 1/2 Ton Over 8800 to 16,000 lb. GVW - Field Inst.....	2500397	12				43
	4 - 5 - 6 - 8 - 10 (Exc. Tandem) Air Over Hydraulic.....	375756	14				47
	Various Models, Air Over Hydraulic (Midland).....	N4105D	19				49
	7000 - 9000 Series.....	376500	9				38
	1 1/2 - 2 Ton School Bus (Under 20,000 lb. GVW).....	374000	13				27
	1951	4 - 5 - 6 - 8 - 10 (Exc. Tandem) Air Over Hydraulic.....	375756	14			
1951	Various Models, Air Over Hydraulic (Midland).....	N4105D	19				49
	7000 - 9000 Series.....	376500	9				38
	1 1/2 - 2 Ton School Bus (Under 20,000 lb. GVW).....	374000	13				27
1950-47	Various Models, Air Over Hydraulic (Midland).....	N4105D	19				49
	1 1/2 - 2 Ton School Bus (Under 20,000 lb. GVW).....	374000	13				27
1946	1 1/2 - 2 Ton School Bus (Under 20,000 lb. GVW).....	374000	13				27

**CLARK EQUIPMENT**

**VARIOUS MODELS**

1982-72	Master Vac (w/ Pedal Rod).....	2700204	16	3700204	11	CE2	1
	Hydro Vac (Remote Mount).....	2503151	24				34
	Piston Type Hydro Vac (Remote Mount).....	374000F	13				43
1971-65	Hydro Vac (Remote Mount).....	2503151	24				34
	Piston Type Hydro Vac (Remote Mount).....	374000	13				43
1964-61	Piston Type Hydro Vac (Remote Mount).....	374000	13				43
1960-59	Piston Type Hydro Vac (Remote Mount).....	374000	13				43
	Piston Type Hydro Vac (Remote Mount).....	374980	22				45
1958-51	Piston Type Hydro Vac (Remote Mount).....	374980	22				45

**DIAMOND T**

**VARIOUS MODELS**

1967	Air/Over Hydraulic (Mini Pak).....	2500506	9				48
1966-63	3014.....	374000	13				27
	622, 28M, 620 (6 Wheel).....	374300	44				46
	Air/Over Hydraulic (Mini Pak).....	2500506	9				48
1962	3014.....	374000	13				27
	622, 28M, 620 (6 Wheel).....	374300	44				46
	Air/Over Hydraulic.....	375844	15				47
	Air/Over Hydraulic (Mini Pak).....	2500506	9				48
	Hydro Vac.....	376155	18				41
1961-60	3014.....	374000	13				27
	622, 28M, 620 (6 Wheel).....	374300	44				46
	Air/Over Hydraulic.....	375844	15				47
	Air/Over Hydraulic.....	375440	15				47
	Air/Over Hydraulic (Mini Pak).....	2500506	9				48
	Air/Over Hydraulic 720C, SPL, SLD Models.....	375757	16				47
1959-51	3014.....	374000	13				27
	323C, 420, 422, 520, 522, 531, 532						

**MEDIUM DUTY TRUCK APPLICATIONS**



**M  
E  
D  
I  
U  
M  
D  
U  
T  
Y  
A  
P  
P  
L  
I  
C  
A  
T  
I  
O  
N  
S**

YEAR	DIAMOND T CONT'D VEHICLE - MODEL	HYD VAC or P.S. & M.C.	Wt. Lbs	POWER SEC. w/o M.C.	Wt. Lbs	PEDAL ROD CODE	PICT. NO.
1959-51	404 SC-SCH, 509H-SC-SCH, 430C.....	374980	22				45
	614H-SC, 360H, 662, C531, 730C.....	374750	25				46
	622, 28M, 620 (6 Wheel).....	374300	44				46
	720C, SLD, SPL, 730C, SLD.....	374229	47				46
	Air/Over Hydraulic.....	375844	15				47
	Air/Over Hydraulic.....	375440	15				47
	Air/Over Hydraulic 720C, SPL, SLD Models.....	375757	16				47
	Eaton Axle 720, 730C.....	374750	25				46
Various Models.....	374230	52				46	
1950-49	3014.....	374000	13				27
	323C, 420, 422, 520, 522, 531, 532.....						
	404 SC-SCH, 509H-SC-SCH, 430C.....	374980	22				45
	614H-SC, 360H, 662, C531, 730C.....	374750	25				46
	622, 28M, 620 (6 Wheel).....	374300	44				46
	720C, SLD, SPL, 730C, SLD.....	374229	47				46
	Eaton Axle 720, 730C.....	374750	25				46
	Various Models.....	374230	52				46
1948-47	404 SC-SCH, 509H-SC-SCH, 430C, 531, 532.....	374980	22				45
	614H-SC, 360H, 662, C531, 730C.....	374750	25				46
	622, 28M, 620 (6 Wheel).....	374300	44				46
	720C, SLD, SPL, 730C, SLD.....	374229	47				46
	Various Models.....	374230	52				46
1946	622, 28M, 620 (6 Wheel).....	374300	44				46
	Various Models.....	374230	52				46

**DIVCO  
MEDIUM DUTY**

1969-67	200-205 Series 15,000 - 18,000 GVW.....	C462	17				17
1966-60	200-205 Series 15,000 - 18,000 GVW.....	C462	17				17
	All.....	374000	13				27
1959-56	200-205 Series 15,000 - 18,000 GVW.....	C462	17				17
	300-306 Series 11,000 - 15,000 GVW.....	C468	13				16
	All.....	374000	13				27
1955	All.....	374000	13				27

**DODGE TRUCK  
MEDIUM DUTY**

1982-81	CB, MB, 300 - 450 w/ 3.6 M Front Axle (Exc. Transverse Mounted Booster).....	2700217	14	3700217	11	DT23<1>	4,5
	D400.....	2700219	12	3700219	11	DT21	1
	W400 w/ 4.5 M front axle.....	2700221	26	3700221	14	DT16	3
	CB, MB, 300 - 450 w/ 4.0 M Front Axle (All Transverse Mounted Booster w/ 3.6 M Front Axle).....	2700223	15	3700223	11	DT22	1
1980	M 400 - 500 Motor Home Hydro Boost.....	2700243	21	3700243	14	DT2	
1980	CB, MB, 300 - 450 w/ 3.6 M Front Axle (Exc. Transverse Mounted Booster).....	2700217	14	3700217	11	DT23<1>	4,5
	D400.....	2700219	12	3700219	11	DT21	1
	W400 w/ 4.5 M front axle.....	2700221	26	3700221	14	DT16	3
	CB, MB, 300 - 450 w/ 4.0 M Front Axle (All Transverse Mounted Booster w/ 3.6 M Front Axle).....	2700223	15	3700223	11	DT22	1
	1979	CB, MB, 300 - 450 w/ 3.6 M Front Axle (Exc. Transverse Mounted Booster).....	2700217	14	3700217	11	DT23<1>

YEAR	DODGE TRUCK CONT'D VEHICLE - MODEL	HYD VAC or P.S. & M.C.	Wt. Lbs	POWER SEC. w/o M.C.	Wt. Lbs	PEDAL ROD CODE	PICT. NO.
1979	D400.....	2700219	12	3700219	11	DT21	1
	W400 w/ 4.5 M front axle.....	2700221	26	3700221	14	DT16	3
	CB, MB, 300 - 450 w/ 4.0 M Front Axle (All Transverse Mounted Booster w/ 3.6 M Front Axle).....	2700223	15	3700223	11	DT22	1
1978	W400 w/ 4.5 M front axle.....	2700221	26	3700221	14	DT16	3
	Disc M - R300 Motor Home, w/ breather tube.....	2510680	19	3510680	11	DT7,DT10<1>	1
	M400 - 500, M 600 2 Ton Motor Home Hydro Boost (Inc. 78 CB - MB).....	2700194	21	3700194	14	<6>	
	D400.....	2510033	18	3510033	11	DT6<1>	1
1977	W400 w/ 4.5 M front axle.....	2700221	26	3700221	14	DT16	3
	Disc M - R300 Motor Home, w/ breather tube.....	2510680	19	3510680	11	DT7,DT10<1>	1
	M400 - 500, M 600 2 Ton Motor Home Hydro Boost (Inc. 78 CB - MB).....	2700194	21	3700194	14	<6>	
	Disc CB - MB300, Exc. 163" wheel base.....	2508557	18	3508557	11	DT3,DT5<1>	1
	D80 w/ 9000 lb. front axle & C1000 - CT800 - W5000 (two units req'd).....	2510027	24				34
	R400 - 500 Motor Home.....	2510813	21				34
	WT500, 3/4 Ton Various Models.....	C448	36				32
	P - M300 if Midland frame mount: w/ Perforated breather.....	C490	13				16
	w/ Atmospheric tube breather.....	C490G	13				16
	D - P - C - W 400 - 500 - 600 - 700 - 800.....	C464	20				22
1976-75	W400 w/ 4.5 M front axle.....	2700221	26	3700221	14	DT16	3
	Disc M - R300 Motor Home, w/ breather tube.....	2510680	19	3510680	11	DT7,DT10<1>	1
	M400 - 500, M 600 2 Ton Motor Home Hydro Boost (Inc. 78 CB - MB).....	2700194	21	3700194	14	<6>	
	Disc CB - MB300, Exc. 163" wheel base.....	2508557	18	3508557	11	DT3,DT5<1>	1
	D80 w/ 9000 lb. front axle & C1000 - CT800 - W5000 (two units req'd).....	2510027	24				34
	R400 - 500 Motor Home.....	2510813	21				34
	WT500, 3/4 Ton Various Models.....	C448	36				32
	P - M300 if Midland frame mount: w/ Perforated breather.....	C490	13				16
	w/ Atmospheric tube breather.....	C490G	13				16
	D - P - C - W 400 - 500 - 600 - 700 - 800.....	C464	20				22
S 500 Bus (firewall mount).....	C4083F	31	C4084JW	20		8	
1974	Disc M - R300 Motor Home, w/ breather tube.....	2510680	19	3510680	11	DT7,DT10<1>	1
	M400 - 500, M 600 2 Ton Motor Home Hydro Boost (Inc. 78 CB - MB).....	2700194	21	3700194	14	<6>	
	Disc CB - MB300, Exc. 163" wheel base.....	2508557	18	3508557	11	DT3,DT5<1>	1
	D80 w/ 9000 lb. front axle & C1000 - CT800 - W5000 (two units req'd).....	2510027	24				34
	R400 - 500 Motor Home.....	2510813	21				34
1974	WT500, 3/4 Ton Various Models.....	C448	36				32
	P - M300 if Midland frame mount: w/ Perforated breather.....	C490	13				16
	w/ Atmospheric tube breather.....	C490G	13				16
	D - P - C - W 400 - 500 - 600 - 700 - 800.....	C464	20				22
S 500 Bus (firewall mount).....	C4083F	31	C4084JW	20		8	
1973	Disc M - R300 Motor Home, w/ breather tube.....	2510680	19	3510680	11	DT7,DT10<1>	1

**M  
E  
D  
I  
U  
M  
D  
U  
T  
Y  
A  
P  
P  
L  
I  
C  
A  
T  
I  
O  
N  
S**

# MEDIUM DUTY TRUCK APPLICATIONS



MEDIUM DUTY APPLICATIONS

YEAR	DODGE TRUCK CONT'D VEHICLE - MODEL	HYD VAC or P.S. & M.C.	Wt. Lbs	POWER SEC. w/o M.C.	Wt. Lbs	PEDAL ROD CODE	PICT. NO.
1973	M400 - 500, M 600 2 Ton Motor Home Hydro Boost (Inc. 78 CB - MB).....	2700194	21	3700194	14	<6>	
	Disc CB - MB300, Exc. 163" wheel base.....	2508557	18	3508557	11	DT3,DT5<1>	1
	D80 w/ 9000 lb. front axle & C1000 - CT800 - W5000 (two units req'd).....	2510027	24				34
	R400 - 500 Motor Home.....	2510813	21				34
	WT500, 3/4 Ton Various Models.....	C448	36				32
	P - M300 if Midland frame mount: w/ Perforated breather.....	C490	13				16
	w/ Atmospheric tube breather.....	C490G	13				16
	D - P - C - W 400 - 500 - 600 - 700 - 800.....	C464	20				22
	Disc M300 Motor Home, w/breather tube.....	2510088	17	3510680	11	DT7,DT10<1>	1
	Bus S500 - 600 Opt. D400 - 500 - 700 (firewall mount).....	C4083	31	C4084JJ	20		8
1972	WT500, 3/4 Ton Various Models.....	C448	36				32
	P - M300 if Midland frame mount: w/ Perforated breather.....	C490	13				16
	w/ Atmospheric tube breather.....	C490G	13				16
	D - P - C - W 400 - 500 - 600 - 700 - 800.....	C464	20				22
	Disc M300 Motor Home, w/breather tube.....	2510088	17	3510680	11	DT7,DT10<1>	1
	Bus S500 - 600 Opt. D400 - 500 - 700 (firewall mount).....	C4083	31	C4084JJ	20		8
1971	WT500, 3/4 Ton Various Models.....	C448	36				32
	P - M300 if Midland frame mount: w/ Perforated breather.....	C490	13				16
	w/ Atmospheric tube breather.....	C490G	13				16
	D - P - C - W 400 - 500 - 600 - 700 - 800.....	C464	20				22
	Disc M300 Motor Home, w/breather tube.....	2510088	17	3510680	11	DT7,DT10<1>	1
	Bus S500 - 600 Opt. D400 - 500 - 700 (firewall mount).....	C4083	31	C4084JJ	20		8
	VT462 - 466 - 468, CT 800 - 900.....	377839	47				46
M375 Motor Home.....	2510027	24				34	
1970-69	P - M300 if Midland frame mount: w/ Perforated breather.....	C490	13				16
	w/ Atmospheric tube breather.....	C490G	13				16
	D - P - C - W 400 - 500 - 600 - 700 - 800.....	C464	20				22
	Bus S500 - 600 Opt. D400 - 500 - 700 (firewall mount).....	C4083	31	C4084JJ	20		8
	VT462 - 466 - 468, CT 800 - 900.....	377839	47				46
1968	D - P - C - W 400 - 500 - 600 - 700 - 800.....	C464	20				22
	Bus S500 - 600 Opt. D400 - 500 - 700 (firewall mount).....	C4083	31	C4084JJ	20		8
	VT462 - 466 - 468, CT 800 - 900.....	377839	47				46
1967	D - P - C - W 400 - 500 - 600 - 700 - 800.....	C464	20				22
	VT462 - 466 - 468, CT 800 - 900.....	377839	47				46
1967	Various models Clutch Assist.....	2502702	9				48
	Various Models.....	375680	17				41
	Various models Air Over Hydraulic.....	376504	14				47
1966-65	D - P - C - W 400 - 500 - 600 - 700 - 800.....	C464	20				22
	VT462 - 466 - 468, CT 800 - 900.....	377839	47				46
	Various models Clutch Assist.....	2502702	9				48
	Various Models.....	375680	17				41
	Various models Air Over Hydraulic.....	376504	14				47

YEAR	DODGE TRUCK CONT'D VEHICLE - MODEL	HYD VAC or P.S. & M.C.	Wt. Lbs	POWER SEC. w/o M.C.	Wt. Lbs	PEDAL ROD CODE	PICT. NO.
1966-65	3 - 4 - 5 Ton Clutch Assist.....	2500187	9				48
	WT500, 3/4 Ton Various Models.....	C448	36				32
1964	D - P - C - W 400 - 500 - 600 - 700 - 800.....	C464	20				22
	VT462 - 466 - 468, CT 800 - 900.....	377839	47				46
	Various models Clutch Assist.....	2502702	9				48
	Various Models.....	375680	17				41
	Various models Air Over Hydraulic.....	376504	14				47
	3 - 4 - 5 Ton Clutch Assist.....	2500187	9				48
	Various models - Field Inst.....	374000	13				27
WT500, 3/4 Ton Various Models.....	C448	36				32	
1963	D - P - C - W 400 - 500 - 600 - 700 - 800.....	C464	20				22
	VT462 - 466 - 468, CT 800 - 900.....	377839	47				46
	Various models Clutch Assist.....	2502702	9				48
	Various Models.....	375680	17				41
	Various models Air Over Hydraulic.....	376504	14				47
	Various models - Field Inst.....	374000	13				27
	WT500, 3/4 Ton Various Models.....	C448	36				32
1962	D - P - C - W 400 - 500 - 600 - 700 - 800.....	C464	20				22
	VT462 - 466 - 468, CT 800 - 900.....	377839	47				46
	Various Models.....	375680	17				41
	Various models Air Over Hydraulic.....	376504	14				47
	Various models - Field Inst.....	374000	13				27
	WT500, 3/4 Ton Various Models.....	C448	36				32
	1961	D - P - C - W 400 - 500 - 600 - 700 - 800.....	C464	20			
VT462 - 466 - 468, CT 800 - 900.....		377839	47				46
Various models - Field Inst.....		374000	13				27
Various models Air Over Hydraulic - Field Inst.....		N4105D	19				49
WT500, 3/4 Ton Various Models.....		C448	36				32
1960	D - P - C - W 400 - 500 - 600 - 700 - 800.....	C464	20				22
	VT462 - 466 - 468, CT 800 - 900.....	377839	47				46
	Various models - Field Inst.....	374000	13				27
	Various models Air Over Hydraulic.....	375756	14				47
	Various models Air Over Hydraulic - Field Inst.....	N4105D	19				49
	WT500, 3/4 Ton Various Models.....	C448	36				32
1959-56	D - P - C - W 400 - 500 - 600 - 700 - 800.....	C464	20				22
	VT462 - 466 - 468, CT 800 - 900.....	377839	47				46
	Various models - Field Inst.....	374000	13				27
	Various models Air Over Hydraulic - Field Inst.....	N4105D	19				49
	WT500, 3/4 Ton Various Models.....	C448	36				32
1955-53	D - P - C - W 400 - 500 - 600 - 700 - 800.....	C464	20				22
	Various models - Field Inst.....	374000	13				27
	Various models Air Over Hydraulic - Field Inst.....	N4105D	19				49
	WT500, 3/4 Ton Various Models.....	C448	36				32
1952	D - P - C - W 400 - 500 - 600 - 700 - 800.....	C464	20				22
1952	Various models Air Over Hydraulic - Field Inst.....	N4105D	19				49
	1 1/2 - 2 Ton.....	C449	23				21
	WT500, 3/4 Ton Various Models.....	C448	36				32
1951-49	Various models Air Over Hydraulic - Field Inst.....	N4105D	19				49
	1 1/2 - 2 Ton.....	C449	23				21
	WT500, 3/4 Ton Various Models.....	C448	36				32

**M  
E  
D  
I  
U  
M  
D  
U  
T  
Y  
A  
P  
P  
L  
I  
C  
A  
T  
I  
O  
N  
S**

# MEDIUM DUTY TRUCK APPLICATIONS



MEDIUM DUTY APPLICATIONS

YEAR	DODGE TRUCK CONT'D VEHICLE - MODEL	HYD VAC or P.S. & M.C.	Wt. Lbs	POWER SEC. w/o M.C.	Wt. Lbs	PEDAL ROD CODE	PICT. NO.
1948-47	Various models Air Over Hydraulic - Field Inst.....	N4105D	19				49
	1 1/2 - 2 Ton.....	C449	23				21
1946	1 1/2 - 2 Ton.....	C449	23				21
<b>FORD TRUCK</b>							
MEDIUM DUTY							
B500 School Bus							
1979-78	w/dual Master Cyl.: front axle unit.....	2509558	24				34
	rear axle unit.....	2501350	24				33
1977	w/dual Master Cyl.: front axle unit.....	2509558	24				34
	rear axle unit.....	2501350	24				33
	w/single Master Cyl. w/ 6 3/4 " pedal rod, (firewall mount)<9>.....	C4085H	28	C4084E	20		8
	w/dual Master Cyl. w/ 6 3/4" pedal rod, (firewall mount)<9>.....	C4085G	31	C4084E	20		8
	w/dual system Hydro-vac: (two units req'd).....	2501350	24				33
1976-74	w/dual Master Cyl.: front axle unit.....	2509558	24				34
	rear axle unit.....	2501350	24				33
	w/single Master Cyl. w/ 6 3/4 " pedal rod, (firewall mount)<9>.....	C4085H	28	C4084E	20		8
	w/dual Master Cyl. w/ 6 3/4" pedal rod, (firewall mount)<9>.....	C4085G	31	C4084E	20		8
1973	w/dual Master Cyl.: front axle unit.....	2509558	24				34
	rear axle unit.....	2501350	24				33
	w/single Master Cyl. w/ 6 3/4 " pedal rod, (firewall mount)<9>.....	C4085H	28	C4084E	20		8
	w/dual Master Cyl. w/ 6 3/4" pedal rod, (firewall mount)<9>.....	C4085G	31	C4084E	20		8
1972	w/dual Master Cyl. Duo-Vac<10>.....	2509140	52				36
	w/dual Master Cyl.: front axle unit.....	2509558	24				34
	rear axle unit.....	2501350	24				33
	w/single Master Cyl. w/ 6 3/4 " pedal rod, (firewall mount)<9>.....	C4085H	28	C4084E	20		8
	w/dual Master Cyl. w/ 6 3/4" pedal rod, (firewall mount)<9>.....	C4085G	31	C4084E	20		8
1971	w/dual Master Cyl. Duo-Vac<10>.....	2509140	52				36
	w/dual Master Cyl.: front axle unit.....	2509558	24				34
	rear axle unit.....	2501350	24				33
	w/single Master Cyl. w/ 6 3/4 " pedal rod, (firewall mount)<9>.....	C4085H	28	C4084E	20		8
	w/dual Master Cyl. w/ 6 3/4" pedal rod, (firewall mount)<9>.....	C4085G	31	C4084E	20		8
1971	w/dual system Hydro-vac: (two units req'd).....	2501350	24				33
	w/single Master Cyl. w/Hydro-vac.....	2501350	24				33
1970-69	w/dual Master Cyl. Duo-Vac<10>.....	2509140	52				36
	w/single Master Cyl. w/ 6 3/4 " pedal rod, (firewall mount)<9>.....	C4085H	28	C4084E	20		8
	w/dual Master Cyl. w/ 6 3/4" pedal rod, (firewall mount)<9>.....	C4085G	31	C4084E	20		8

<9> Customer Must Re-use Own Spacer Plate, Located On the Rear Can Over the Four Mounting Studs

<10> If Two Units, Use 2-2509558's

YEAR	FORD TRUCK CONT'D VEHICLE - MODEL	HYD VAC or P.S. & M.C.	Wt. Lbs	POWER SEC. w/o M.C.	Wt. Lbs	PEDAL ROD CODE	PICT. NO.
1970-69	w/single Master Cyl. w/Hydro-vac.....	2501350	24				33
1968	w/single Master Cyl. w/ 6 3/4 " pedal rod, (firewall mount)<9>.....	C4085H	28	C4084E	20		8
	w/dual Master Cyl. w/ 6 3/4" pedal rod, (firewall mount)<9>.....	C4085G	31	C4084E	20		8
	w/dual Master Cyl. Duo-Vac<10>.....	2509140	52				36
	w/single Master Cyl. w/Hydro-vac.....	2501350	24				33
	w/ 10 1/4" pedal rod (firewall mount).....	C4029	21	C4028A	14		6
	w/ 7 1/8" pedal rod (firewall mount).....	C4025E	16	C4026B3	12		6
1967	w/single Master Cyl. : w/ Light Duty Hydro-vac.....	2501370	17				33
	w/ Heavy Duty Hydro-vac.....	2501350	24				33
	w/ 5 3/4" pedal rod (firewall mount).....	C4063	19	C4044D	13		7
	w/ 10 1/4" pedal rod (firewall mount).....	C4029	21	C4028A	14		6
	w/ 7 1/8" pedal rod (firewall mount).....	C4025E	16	C4026B3	12		6
1966-64	w/single Master Cyl. : w/ Light Duty Hydro-vac.....	2501370	17				33
	w/ Heavy Duty Hydro-vac.....	2501350	24				33
	w/ 10 1/4" pedal rod (firewall mount).....	C4029	21	C4028A	14		6
	w/ 7 1/8" pedal rod (firewall mount).....	C4025E	16	C4026B3	12		6
1963	w/single Master Cyl. : w/ Light Duty Hydro-vac.....	2501370	17				33
	w/ Heavy Duty Hydro-vac.....	2501350	24				33
	w/ single Master Cyl. w/ Hy-Power Vac. Unit.....	C462	17				17
	w/ 10 1/4" pedal rod (firewall mount).....	C4029	21	C4028A	14		6
	w/ 7 1/8" pedal rod (firewall mount).....	C4025E	16	C4026B3	12		6
1962	w/single Master Cyl. : w/ Light Duty Hydro-vac.....	2501370	17				33
	w/ Heavy Duty Hydro-vac.....	2501350	24				33
	w/ single Master Cyl. w/ Hy-Power Midland Vac. Unit.....	C462	17				17
1961-52	w/ single Master Cyl. w/ Hy-Power Midland Vac. Unit.....	C462	17				17
<b>B600 &amp; 6000 School Bus</b>							
2020-96	Hydromax ( casting # 2772114).....			3700625	7		9
	Elec. Motor - w/stud - 2771320				5		10
	Elec. Motor - w/wire & Pigtail - 2771420				5		10
	Master Cylinder # 2379R (50.80 mm bore) Master Cylinder # 2632R (44.45 mm bore)						
1995-84	Hydromax (casting # 2771293 / 2771371).....			3700273	7		9
1995-84	Elec. Motor - stud type - 2771320				5		10
	Elec. Motor - w/wire & Pigtail - 2771420				5		10
1995-92	Master Cylinder # 2632R						
1991-84	Master Cylinder # 1999R						
1983-77	Hydromax (casting # 2771293 / 2771371).....			3700273	7		9
	Elec. Motor - stud type - 2771320				5		10
	Elec. Motor - w/wire & Pigtail - 2771420				5		10

**M  
E  
D  
I  
U  
M  
D  
U  
T  
Y  
A  
P  
P  
L  
I  
C  
A  
T  
I  
O  
N  
S**

<9> Customer Must Re-use Own Spacer Plate, Located On the Rear Can Over the Four Mounting Studs  
<10> If Two Units, Use 2-2509558's

# MEDIUM DUTY TRUCK APPLICATIONS



**M  
E  
D  
I  
U  
M  
D  
U  
T  
Y  
A  
P  
P  
L  
I  
C  
A  
T  
I  
O  
N  
S**

YEAR	FORD TRUCK CONT'D VEHICLE - MODEL	HYD VAC or P.S. & M.C.	Wt. Lbs	POWER SEC. w/o M.C.	Wt. Lbs	PEDAL ROD CODE	PICT. NO.
1983	Master Cylinder # 1992R						
1982-77	Master Cylinder # 1909R						
1979-70	w/dual system Hydro-vac: front axle unit..... rear axle unit.....	2509558 2501350	24 24				34 33
1968	w/ 10 1/4" pedal rod (firewall mount).....	C4025F	18	C4026B6	12		6
1967	w/ 5 3/4" pedal rod (firewall mount)..... w/single system Hydro-vac..... w/ 10 1/4" pedal rod (firewall mount).....	C4063 2501350 C4025F	19 24 18	C4044D C4026B6	13 12		7 33 6
1966-64	w/single system Hydro-vac..... w/ 10 1/4" pedal rod (firewall mount).....	2501350 C4025F	24 18	C4026B6	12		33 6
1963	w/ 10 1/4" pedal rod (firewall mount)..... w/ single Master Cyl. w/ Hy-Power Vac. Unit.....	C4025F C462	18 17	C4026B6	12		6 17
1962-52	w/ single Master Cyl. w/ Hy-Power Vac. Unit.....	C462	17				17
<b>B700 &amp; 7000 School Bus</b>							
2020-96	Hydromax ( casting # 2772114)..... Elec. Motor - w/stud - 2771320 Elec. Motor - w/wire & Pigtail - 2771420 Master Cylinder # 2379R (50.80 mm bore) Master Cylinder # 2632R (44.45 mm bore)			3700625	7 5 5		9 10 10
1995-84	Hydromax (casting # 2771293 / 2771371)..... Elec. Motor - stud type - 2771320 Elec. Motor - w/wire & Pigtail - 2771420			3700273	7 5 5		9 10 10
1995-92	Master Cylinder # 2632R						
1991-84	Master Cylinder # 1999R						
1983-77	Hydromax (casting # 2771293 / 2771371)..... Elec. Motor - stud type - 2771320 Elec. Motor - w/wire & Pigtail - 2771420			3700273	7 5 5		9 10 10
1983	Master Cylinder # 1992R						
1982-77	Master Cylinder # 1909R						
1979-77	w/dual system Hydro-vac: front axle unit..... rear axle unit.....	2509558 2501350	24 24				34 33
1976-70	w/dual system Hydro-vac: front axle unit..... rear axle unit.....	2501350 2509558	24 24				33 34
1968	w/ 10 1/4" pedal rod (firewall mount).....	C4029	21	C4028A	14		6
1967-64	w/single system Hydro-vac..... w/ 10 1/4" pedal rod (firewall mount)..... Optional Air Over Hydraulic.....	2501350 C4029 375756	24 21 14	C4028A	14		33 6 47
1963	w/ 10 1/4" pedal rod (firewall mount)..... Optional Air Over Hydraulic.....	C4029 375756	21 14	C4028A	14		6 47
1962-54	Optional Air Over Hydraulic.....	375756	14				47
<b>B750 School Bus</b>							
1977	w/dual system Hydro-vac: front axle unit..... rear axle unit..... w/single Master Cyl. w/ 6 3/4 " pedal rod, (firewall mount)<9>.....	2509558 2501350 C4085H	24 24 28				34 33 8

YEAR	FORD TRUCK CONT'D VEHICLE - MODEL	HYD VAC or P.S. & M.C.	Wt. Lbs	POWER SEC. w/o M.C.	Wt. Lbs	PEDAL ROD CODE	PICT. NO.
1976-70	w/dual system Hydro-vac: front axle unit.....	2501350	24				33
	rear axle unit.....	2509558	24				33
	w/single Master Cyl. w/ 6 3/4 " pedal rod, (firewall mount)<9>.....	C4085H	28	C4084E	20		8
1969-68	w/single Master Cyl. w/ 6 3/4 " pedal rod, (firewall mount)<9>.....	C4085H	28	C4084E	20		8
1967-64	w/single system Hydro-vac.....	2501350	24				33
	w/single Master Cyl. w/ Light Duty Hydro-vac.....	2501370	17				33
	w/single Master Cyl. w/ Heavy Duty Hydro-vac.....	2501350	24				33
1963-62	w/single Master Cyl. w/ Light Duty Hydro-vac.....	2501370	17				33
	w/single Master Cyl. w/ Heavy Duty Hydro-vac.....	2501350	24				33
<b>B800 &amp; 8000 School Bus</b>							
2020-96	Hydromax ( casting # 2772114).....			3700625	7		9
	Elec. Motor - w/stud - 2771320				5		10
	Elec. Motor - w/wire & Pigtail - 2771420				5		10
	Master Cylinder # 2379R (50.80 mm bore)						
	Master Cylinder # 2632R (44.45 mm bore)						
1995-84	Hydromax (casting # 2771293 / 2771371).....			3700273	7		9
	Elec. Motor - stud type - 2771320				5		10
	Elec. Motor - w/wire & Pigtail - 2771420				5		10
1995-92	Master Cylinder # 2632R						
1991-84	Master Cylinder # 1999R						
1983-77	Hydromax (casting # 2771293 / 2771371).....			3700273	7		9
	Elec. Motor - stud type - 2771320				5		10
	Elec. Motor - w/wire & Pigtail - 2771420				5		10
1983	Master Cylinder # 1992R						
1982-77	Master Cylinder # 1909R						
<b>B850 School Bus</b>							
1973-68	Split Master Cyl. Duo-Vac<10>.....	2509140	52				36
<b>B900 School Bus</b>							
1971-68	w/single Master Cyl. w/Hydro-vac.....	2501350	24				33
1967-62	Optional Air Over Hydraulic.....	375756	14				47
	w/single Master Cyl. w/Hydro-vac.....	2501350	24				33
1961-54	Optional Air Over Hydraulic.....	375756	14				47
<b>C500 Tilt Cab</b>							
1971-70	w/dual system Hydro-vac: (two units req'd).....	2501350	24				33
1971-70	w/single Master Cyl.....	2501350	24				33
1969-68	w/single Master Cyl.....	2501350	24				33
1967-64	w/single Master Cyl.....	2501350	24				33
	w/single Master Cyl. (light duty).....	2501370	17				33
1963-62	w/single Master Cyl.....	2501350	24				33
	w/single Master Cyl. (light duty).....	2501370	17				33
	w/ single Master Cyl. w/ Hy-Power Vac. Unit.....	C462	17				17

**M  
E  
D  
I  
U  
M  
D  
U  
T  
Y  
A  
P  
P  
L  
I  
C  
A  
T  
I  
O  
N  
S**

<9> Customer Must Re-use Own Spacer Plate, Located On the Rear Can Over the Four Mounting Studs  
<10> If Two Units, Use 2-2509558's

# MEDIUM DUTY TRUCK APPLICATIONS



MEDIUM DUTY APPLICATIONS

YEAR	FORD TRUCK CONT'D VEHICLE - MODEL	HYD VAC or P.S. & M.C.	Wt. Lbs	POWER SEC. w/o M.C.	Wt. Lbs	PEDAL ROD CODE	PICT. NO.
1961-52	w/ single Master Cyl. w/ Hy-Power Vac. Unit.....	<b>C462</b>	17				17
<b>C500 Tilt Cab</b>							
1970-68	w/single system Hydro-vac.....	<b>2501350</b>	24				33
	w/dual system Hydro-vac: (two units req'd).....	<b>2501350</b>	24				33
<b>C600 Tilt Cab</b>							
2020-97	Hydromax (casting # 2772114)..... Elec. Motor - stud type - 2771320 Elec. Motor - w/wire & pigtail - 2771420 Master Cylinder # 2379R			<b>3700625</b>	7 5 5		9 10 10
1996-84	Hydromax (casting # 2771293 / 2771371)..... Elec. Motor - stud type - 2771320 Elec. Motor - w/wire & pigtail - 2771420			<b>3700273</b>	7 5 5		9 10 10
1996-92	Master Cylinder # 2632R						
1991-84	Master Cylinder # 1999R						
1983-81	w/single Master Cyl..... w/single system Hydro-vac..... w/dual system Hydro-vac: (two units req'd).....	<b>2509558</b> <b>2510065</b> <b>2501350</b>	24 25 24				34 34 33
1980-77	w/single Master Cyl..... Split Master Cyl. w/dual system Hydro-vac: (two units req'd)..... w/single system Hydro-vac..... w/dual system Hydro-vac: (two units req'd).....	<b>2509558</b> <b>2501350</b> <b>2510065</b> <b>2501350</b>	24 24 25 24				34 33 34 33
1976-73	Split Master Cyl. w/dual system Hydro-vac: (two units req'd)..... w/single system Hydro-vac..... w/dual system Hydro-vac: (two units req'd).....	<b>2501350</b> <b>2510065</b> <b>2501350</b>	24 25 24				33 34 33
1972-70	w/single system Hydro-vac..... w/dual system Hydro-vac: (two units req'd).....	<b>2510065</b> <b>2501350</b>	25 24				34 33
1969-64	w/single system Hydro-vac.....	<b>2501350</b>	24				33
1963	w/single system Hydro-vac..... w/ single Master Cyl. w/ Hy-Power Vac. Unit.....	<b>2501350</b> <b>C462</b>	24 17				33 17
1962-52	w/ single Master Cyl. w/ Hy-Power Vac. Unit.....	<b>C462</b>	17				17
<b>C700 &amp; 7000 Tilt Cab</b>							
2020-97	Hydromax (casting # 2772114)..... Elec. Motor - stud type - 2771320 Elec. Motor - w/wire & pigtail - 2771420 Master Cylinder # 2379R			<b>3700625</b>	7 5 5		9 10 10
1996-84	Hydromax (casting # 2771293 / 2771371)..... Elec. Motor - stud type - 2771320 Elec. Motor - w/wire & pigtail - 2771420			<b>3700273</b>	7 5 5		9 10 10
1996-92	Master Cylinder # 2632R						

YEAR	FORD TRUCK CONT'D VEHICLE - MODEL	HYD VAC or P.S. & M.C.	Wt. Lbs	POWER SEC. w/o M.C.	Wt. Lbs	PEDAL ROD CODE	PICT. NO.
1991-84	Master Cylinder # 1999R						
1983-77	w/dual system Hydro-vac: to ser. G5001 (two units req'd)..... from ser. G5001 (two units req'd)..... w/single system Hydro-vac.....	2510065 2501350 2510065	25 24 25				34 33 34
1976-70	w/single system Hydro-vac..... w/dual system Hydro-vac: (two units req'd)..... w/single Master Cyl.....	2510065 2501350 2501029	25 24 25				34 33 44
1969-68	w/single Master Cyl..... w/single system Hydro-vac.....	2501029 2501350	25 24				44 33
1967-64	w/single Master Cyl..... w/single system Hydro-vac..... w/single Master Cyl. (light duty)..... Optional Air Over Hydraulic.....	2501029 2501350 2501370 375756	25 24 17 14				44 33 33 47
1963-62	w/single Master Cyl..... w/single Master Cyl. (light duty)..... Optional Air Over Hydraulic.....	2501029 2501370 375756	25 17 14				44 33 47
1961-54	Optional Air Over Hydraulic.....	375756	14				47
<b>C750 Tilt Cab</b>							
1977-68	w/single system Hydro-vac..... w/dual system Hydro-vac: (two units req'd).....	2501350 2501350	24 24				33 33
1967-62	w/single system Hydro-vac (light duty)..... w/single system Hydro-vac..... w/dual system Hydro-vac: (two units req'd).....	2501370 2501350 2501350	17 24 24				33 33 33
1961	w/single system Hydro-vac..... w/dual system Hydro-vac: (two units req'd).....	2501350 2501350	24 24				33 33
<b>C800 &amp; 8000 Tilt Cab</b>							
2020-97	Hydromax (casting # 2772114)..... Elec. Motor - stud type - 2771320 Elec. Motor - w/wire & pigtail - 2771420 Master Cylinder # 2379R			3700625	7 5 5		9 10 10
1996-84	Hydromax (casting # 2771293 / 2771371)..... Elec. Motor - stud type - 2771320 Elec. Motor - w/wire & pigtail - 2771420			3700273	7 5 5		9 10 10
1996-92	Master Cylinder # 2632R						
1991-84	Master Cylinder # 1999R						
1983-79	w/single system Hydro-vac (w/ 15x6" rr. brk.).....	2510065	25				34
1978-77	w/single system Hydro-vac: (exc. 15x6" rr. brk.).....	2501350	24				33
1978-77	w/single system Hydro-vac (w/ 15x6" rr. brk.).....	2510065	25				34
1976-70	w/single system Hydro-vac (w/ 15x6" rr. brk.).....	2510065	25				34
1969-68	w/ tandem frame mount.....	2509605	37				35
1967-64	w/ single system Hydro-vac.....	2501350	24				33
<b>C900 &amp; 9000 Tilt Cab</b>							

**M  
E  
D  
I  
U  
M  
D  
U  
T  
Y  
A  
P  
P  
L  
I  
C  
A  
T  
I  
O  
N  
S**

# MEDIUM DUTY TRUCK APPLICATIONS



MEDIUM DUTY APPLICATIONS

YEAR	FORD TRUCK CONT'D VEHICLE - MODEL	HYD VAC or P.S. & M.C.	Wt. Lbs	POWER SEC. w/o M.C.	Wt. Lbs	PEDAL ROD CODE	PICT. NO.
1983-82	w/ single Master Cyl.....	2509558	24				34
1981-77	w/ single Master Cyl.....	2509558	24				34
	w/ single system Hydro-vac.....	2501350	24				33
	w/ dual system Hydro-vac: (two units req'd).....	2501350	24				33
1976-73	w/ single system Hydro-vac.....	2501350	24				33
	w/ dual system Hydro-vac: (two units req'd).....	2501350	24				33
	w/ single system Hydro-vac.....	2510065	25				34
1972	w/ single system Hydro-vac.....	2510065	25				34
1971-70	w/ single system Hydro-vac.....	2510065	25				34
	w/ single Master Cyl.....	2501350	24				33
	w/ single Master Cyl.....	2501029	25				44
1969-68	w/ single Master Cyl.....	2501350	24				33
	w/ single Master Cyl.....	2501029	25				44
1967-62	w/ single Master Cyl.....	2501350	24				33
	w/ single Master Cyl.....	2501029	25				44
	Optional Air Over Hydraulic.....	375756	14				47
1961-54	Optional Air Over Hydraulic.....	375756	14				47
<b>F500 Conventional Cab</b>							
1977	w/single Master Cyl. w/ 6 3/4 " pedal rod, (firewall mount)<9>.....	C4085H	28	C4084E	20		8
	w/dual Master Cyl. w/ 6 3/4" pedal rod, (firewall mount)<9>.....	C4085G	31	C4084E	20		8
1976-72	w/single Master Cyl. w/ 6 3/4 " pedal rod, (firewall mount)<9>.....	C4085H	28	C4084E	20		8
	w/dual Master Cyl. w/ 6 3/4" pedal rod, (firewall mount)<9>.....	C4085G	31	C4084E	20		8
	w/single system Hydro-vac.....	2510065	25				34
1971-70	Various models.....	2508177	25				44
	w/single Master Cyl. w/ 6 3/4 " pedal rod, (firewall mount)<9>.....	C4085H	28	C4084E	20		8
	w/dual Master Cyl. w/ 6 3/4" pedal rod, (firewall mount)<9>.....	C4085G	31	C4084E	20		8
	w/single system Hydro-vac.....	2510065	25				34
	Various models: (has bracket on opposite side).....	2507224	38				35
1969	w/single Master Cyl. w/ 6 3/4 " pedal rod, (firewall mount)<9>.....	C4085H	28	C4084E	20		8
	w/dual Master Cyl. w/ 6 3/4" pedal rod, (firewall mount)<9>.....	C4085G	31	C4084E	20		8
	w/single system Hydro-vac.....	2510065	25				34
	Various models: (has bracket on opposite side).....	2507224	38				35
1968	w/single Master Cyl. w/ 6 3/4 " pedal rod, (firewall mount)<9>.....	C4085H	28	C4084E	20		8
	w/dual Master Cyl. w/ 6 3/4" pedal rod, (firewall mount)<9>.....	C4085G	31	C4084E	20		8
	w/single system Hydro-vac.....	2510065	25				34
	Various models: (has bracket on opposite side).....	2507224	38				35
	w/ 10 1/4" pedal rod (firewall mount).....	C4029	21	C4028A	14		6
	w/ 7 1/8" pedal rod (firewall mount).....	C4025E	16	C4026B3	12		6
1967	w/ 5 3/4" pedal rod (firewall mount).....	C4063	19	C4044D	13		7
	w/ 10 1/4" pedal rod (firewall mount).....	C4029	21	C4028A	14		6

YEAR	FORD TRUCK CONT'D VEHICLE - MODEL	HYD VAC or P.S. & M.C.	Wt. Lbs	POWER SEC. w/o M.C.	Wt. Lbs	PEDAL ROD CODE	PICT. NO.
1967	w/ 7 1/8" pedal rod (firewall mount).....	C4025E	16	C4026B3	12		6
	w/single Master Cyl. w/ Light Duty Hydro-vac.....	2501370	17				33
	Various models.....	2500521	12				42
1966-64	w/ 10 1/4" pedal rod (firewall mount).....	C4029	21	C4028A	14		6
	w/ 7 1/8" pedal rod (firewall mount).....	C4025E	16	C4026B3	12		6
	w/single Master Cyl. w/ Light Duty Hydro-vac.....	2501370	17				33
	Various models.....	2500521	12				42
	9500 lb - 16,000 lb GVW Field Inst.....	2500397	12				43
1963	w/ 10 1/4" pedal rod (firewall mount).....	C4029	21	C4028A	14		6
	w/ 7 1/8" pedal rod (firewall mount).....	C4025E	16	C4026B3	12		6
	w/single Master Cyl. w/ Light Duty Hydro-vac.....	2501370	17				33
	Various models.....	2500521	12				42
	Various models Air Over Hydraulic.....	2501975	17				47
	9500 lb - 16,000 lb GVW Field Inst.....	2500397	12				43
	Hy-Power Vac. Unit.....	C462	17				17
	Various models Air Over Hydraulic.....	N4105D	19				49
1962	w/single Master Cyl. w/ Light Duty Hydro-vac.....	2501370	17				33
	Various models.....	2500521	12				42
	Various models Air Over Hydraulic.....	2501975	17				47
	9500 lb - 16,000 lb GVW Field Inst.....	2500397	12				43
	Hy-Power Vac. Unit.....	C462	17				17
	Various models Air Over Hydraulic.....	N4105D	19				49
1961	Various models.....	2500521	12				42
	9500 lb - 16,000 lb GVW Field Inst.....	2500397	12				43
	Hy-Power Vac. Unit.....	C462	17				17
	Various models Air Over Hydraulic.....	N4105D	19				49
1960	9500 lb - 16,000 lb GVW Field Inst.....	2500397	12				43
	Hy-Power Vac. Unit.....	C462	17				17
	Various models Air Over Hydraulic.....	N4105D	19				49
1959-53	9500 lb - 16,000 lb GVW Field Inst.....	2500397	12				43
	Hy-Power Vac. Unit.....	C462	17				17
	Various models Air Over Hydraulic.....	375440	15				47
	Various models Air Over Hydraulic.....	N4105D	19				49
1952	Hy-Power Vac. Unit.....	C462	17				17
	Various models Air Over Hydraulic.....	375440	15				47
	Various models Air Over Hydraulic.....	N4105D	19				49
	Hy-Power Vac. Unit.....	C447	19				19
1951-50	Various models Air Over Hydraulic.....	375440	15				47
	Hy-Power Vac. Unit.....	C447	19				19
	Various models Air Over Hydraulic.....	N4105D	19				49
1949	Hy-Power Vac. Unit.....	C447	19				19
	Various models Air Over Hydraulic.....	N4105D	19				49
1948-47	Various models Air Over Hydraulic.....	N4105D	19				49
<b>F600 &amp; 6000 Conventional Cab</b>							
2020-97	Hydromax (casting # 2772114).....			3700625	7		9
	Elec. Motor - stud type - 2771320				5		10
	Elec. Motor - w/wire & pigtail - 2771420				5		10
	Master Cylinder # 2379R						
1996-84	hydromax (casting # 2771293 / 2771371).....			3700273	7		9

**M  
E  
D  
I  
U  
M  
D  
U  
T  
Y  
A  
P  
P  
L  
I  
C  
A  
T  
I  
O  
N  
S**

# MEDIUM DUTY TRUCK APPLICATIONS



MEDIUM DUTY APPLICATIONS

YEAR	FORD TRUCK CONT'D VEHICLE - MODEL	HYD VAC or P.S. & M.C.	Wt. Lbs	POWER SEC. w/o M.C.	Wt. Lbs	PEDAL ROD CODE	PICT. NO.
1996-84	Elec. Motor - stud type - 2771320				5		10
	Elec. Motor - w/wire & pigtail - 2771420				5		10
1996-92	Master Cylinder # 2632R						
1991-84	Master Cylinder # 1999R						
1983-80	Hydromax (casting # 2771293 / 2771371).....			3700273	7		9
	Elec. Motor - stud type - 2771320				5		10
	Elec. Motor - w/wire & pigtail - 2771420				5		10
	Master Cylinder (single outlet) # 1909R						
	Master Cylinder (dual outlet) # 1992R						
	w/single system Hydro-vac.....	2509558	24				34
w/single Master Cyl. w/Gas Engine.....	2509558	24				34	
w/dual system Hydro-vac:							
front axle unit.....	2501350	24				33	
rear axle unit.....	2509558	24				34	
1979-74	w/dual system Hydro-vac:						
	front axle unit.....	2501350	24			33	
	rear axle unit.....	2509558	24			34	
	w/single system Hydro-vac.....	2510065	25			34	
1973-72	w/dual system Hydro-vac:						
	front axle unit.....	2501350	24			33	
	rear axle unit.....	2509558	24			34	
	w/single system Hydro-vac.....	2510065	25			34	
1971	w/dual Master Cyl. Duo-Vac<10>.....	2509140	52			36	
	front axle unit.....	2501350	24			33	
	rear axle unit.....	2509558	24			34	
	w/single system Hydro-vac.....	2510065	25			34	
	Various models.....	2508177	25			44	
	(has bracket on opposite side).....	2507224	38			35	
1970	Various models.....	2508177	25			44	
	w/dual Master Cyl. Duo-Vac<10>.....	2509140	52			36	
	(has bracket on opposite side).....	2507224	38			35	
1969-68	w/dual Master Cyl. Duo-Vac<10>.....	2509140	52			36	
	(has bracket on opposite side).....	2507224	38			35	
1967	w/ 5 3/4" pedal rod (firewall mount).....	C4063	19	C4044D	13		7
	Various models.....	2500521	12				42
1966-64	Various models.....	2500521	12				42
	9500 lb - 16,000 lb GVW Field Inst.....	2500397	12				43
1963-62	Various models.....	2500521	12				42
	Various models Air Over Hydraulic.....	2501975	17				47
	9500 lb - 16,000 lb GVW Field Inst.....	2500397	12				43
	Hy-Power Vac. Unit.....	C462	17				17
1963-62	Various models Air Over Hydraulic.....	N4105D	19				49
	Various models.....	2500521	12				42
1961	9500 lb - 16,000 lb GVW Field Inst.....	2500397	12				43
	Hy-Power Vac. Unit.....	C462	17				17
	Various models Air Over Hydraulic.....	N4105D	19				49
	Various models.....	2500521	12				42
1960	9500 lb - 16,000 lb GVW Field Inst.....	2500397	12				43
	Hy-Power Vac. Unit.....	C462	17				17
	Various models Air Over Hydraulic.....	N4105D	19				49
1959-53	9500 lb - 16,000 lb GVW Field Inst.....	2500397	12				43

YEAR	FORD TRUCK CONT'D VEHICLE - MODEL	HYD VAC or P.S. & M.C.	Wt. Lbs	POWER SEC. w/o M.C.	Wt. Lbs	PEDAL ROD CODE	PICT. NO.
1959-53	Hy-Power Vac. Unit.....	C462	17				17
	Various models Air Over Hydraulic.....	375440	15				47
	Various models Air Over Hydraulic.....	N4105D	19				49
1952	Hy-Power Vac. Unit.....	C462	17				17
	Various models Air Over Hydraulic.....	375440	15				47
	Hy-Power Vac. Unit.....	C447	19				19
	Various models Air Over Hydraulic.....	N4105D	19				49
1951-50	Various models Air Over Hydraulic.....	375440	15				47
	Hy-Power Vac. Unit.....	C447	19				19
	Various models Air Over Hydraulic.....	N4105D	19				49
1949	Hy-Power Vac. Unit.....	C447	19				19
	Various models Air Over Hydraulic.....	N4105D	19				49
1948-47	Various models Air Over Hydraulic.....	N4105D	19				49
<b>F700 &amp; 7000 Conventional Cab</b>							
2020-97	Hydromax (casting # 2772114).....			3700625	7		9
	Elec. Motor - stud type - 2771320				5		10
	Elec. Motor - w/wire & pigtail - 2771420				5		10
	Master Cylinder # 2379R						
1996-84	hydromax (casting # 2771293 / 2771371).....			3700273	7		9
	Elec. Motor - stud type - 2771320				5		10
	Elec. Motor - w/wire & pigtail - 2771420				5		10
1996-92	Master Cylinder # 2632R						
1991-84	Master Cylinder # 1999R						
1983-80	hydromax (casting # 2771293 / 2771371).....			3700273	7		9
	Elec. Motor - stud type - 2771320				5		10
	Elec. Motor - w/wire & pigtail - 2771420				5		10
1982-80	Master Cylinder (single outlet) # 1909R						
1983	Master Cylinder (dual outlet) # 1992R						
1979-77	w/single system Hydro-vac:						
	w/ 14x2 1/2" frt. brk.....	2510065	25				34
	w/15x3" frt. brk.....	2509558	24				34
	w/dual system Hydro-vac:						
	front axle unit.....	2501350	24				33
	rear axle unit.....	2509558	24				34
1976-73	w/single system Hydro-vac:						
	w/ 14x2 1/2" frt. brk.....	2510065	25				34
	w/15x3" frt. brk.....	2509558	24				34
	w/dual system Hydro-vac:						
	front axle unit.....	2501350	24				33
	rear axle unit.....	2509558	24				34
	w/single Master Cyl.....	2510065	25				34
1972	w/single Master Cyl.....	2510065	25				34
1972	w/dual system Hydro-vac:						
	front axle unit.....	2501350	24				33
	rear axle unit.....	2509558	24				34
	w/single system Hydro-vac.....	2510065	25				34
1971-70	w/dual system Hydro-vac:						
	front axle unit.....	2501350	24				33
	rear axle unit.....	2509558	24				34
	w/single system Hydro-vac.....	2510065	25				34
	Various models.....	2508177	25				44
	Various models:						

# MEDIUM DUTY TRUCK APPLICATIONS



**MEDIUM DUTY APPLICATIONS**

YEAR	FORD TRUCK CONT'D VEHICLE - MODEL	HYD VAC or P.S. & M.C.	Wt. Lbs	POWER SEC. w/o M.C.	Wt. Lbs	PEDAL ROD CODE	PICT. NO.
1971-70	(has bracket on opposite side).....	2507224	38				35
	w/single Master Cyl.....	2501029	25				44
1969	Various models: (has bracket on opposite side).....	2507224	38				35
	w/single system Hydro-vac.....	2501350	24				33
	w/single Master Cyl.....	2501029	25				44
1968	w/single system Hydro-vac.....	2501350	24				33
	w/ 10 1/4" pedal rod (firewall mount).....	C4029	21	C4028A	14		6
	w/ 7 1/8" pedal rod (firewall mount).....	C4025E	16	C4026B3	12		6
	w/single Master Cyl.....	2501029	25				44
Various models: (has bracket on opposite side).....		2507224	38				35
1967	w/single system Hydro-vac.....	2501350	24				33
	w/ 10 1/4" pedal rod (firewall mount).....	C4029	21	C4028A	14		6
	w/ 7 1/8" pedal rod (firewall mount).....	C4025E	16	C4026B3	12		6
	w/single Master Cyl.....	2501029	25				44
	Various models.....	2500521	12				42
Optional Air Over Hydraulic.....	375756	14				47	
1966-65	w/single system Hydro-vac.....	2501350	24				33
	w/ 10 1/4" pedal rod (firewall mount).....	C4029	21	C4028A	14		6
	w/ 7 1/8" pedal rod (firewall mount).....	C4025E	16	C4026B3	12		6
	w/single Master Cyl.....	2501029	25				44
	Various models.....	2500521	12				42
	Optional Air Over Hydraulic.....	375756	14				47
9500 lb - 16,000 lb GVW Field Inst.....	2500397	12				43	
Hydro-vac.....	374980	22				45	
1964	w/ 10 1/4" pedal rod (firewall mount).....	C4029	21	C4028A	14		6
	w/ 7 1/8" pedal rod (firewall mount).....	C4025E	16	C4026B3	12		6
	w/single Master Cyl.....	2501029	25				44
	Various models.....	2500521	12				42
	Optional Air Over Hydraulic.....	375756	14				47
	9500 lb - 16,000 lb GVW Field Inst.....	2500397	12				43
Hydro-vac.....	374980	22				45	
1963	w/ 10 1/4" pedal rod (firewall mount).....	C4029	21	C4028A	14		6
	w/ 7 1/8" pedal rod (firewall mount).....	C4025E	16	C4026B3	12		6
	w/single Master Cyl.....	2501029	25				44
	Various models.....	2500521	12				42
	Optional Air Over Hydraulic.....	375756	14				47
	9500 lb - 16,000 lb GVW Field Inst.....	2500397	12				43
	Various models Air Over Hydraulic.....	2501975	17				47
	Hydro-vac.....	374980	22				45
Various models Air Over Hydraulic.....	N4105D	19				49	
1962	w/single Master Cyl.....	2501029	25				44
	Various models.....	2500521	12				42
	Optional Air Over Hydraulic.....	375756	14				47
	9500 lb - 16,000 lb GVW Field Inst.....	2500397	12				43
	Various models.....	376155	18				41
1962	Various models Air Over Hydraulic.....	2501975	17				47
	Hydro-vac.....	374980	22				45
	Various models Air Over Hydraulic.....	N4105D	19				49
1961	Various models.....	2500521	12				42
	Optional Air Over Hydraulic.....	375756	14				47
	9500 lb - 16,000 lb GVW Field Inst.....	2500397	12				43
	Various models.....	376155	18				41
	Hydro-vac.....	374980	22				45
Various models Air Over Hydraulic.....	N4105D	19				49	

YEAR	FORD TRUCK CONT'D VEHICLE - MODEL	HYD VAC or P.S. & M.C.	Wt. Lbs	POWER SEC. w/o M.C.	Wt. Lbs	PEDAL ROD CODE	PICT. NO.
1960	Optional Air Over Hydraulic.....	375756	14				47
	9500 lb - 16,000 lb GVW Field Inst.....	2500397	12				43
	Various models.....	376155	18				41
	Hydro-vac.....	374980	22				45
	Various models Air Over Hydraulic.....	N4105D	19				49
1959-54	Optional Air Over Hydraulic.....	375756	14				47
	9500 lb - 16,000 lb GVW Field Inst.....	2500397	12				43
	Various models.....	376155	18				41
	Hydro-vac.....	374750	25				46
	Various models Air Over Hydraulic.....	375440	15				47
	Hydro-vac.....	374980	22				45
1953	9500 lb - 16,000 lb GVW Field Inst.....	2500397	12				43
	Various models.....	376155	18				41
	Hydro-vac.....	374750	25				46
	Various models Air Over Hydraulic.....	375440	15				47
	Hydro-vac.....	374980	22				45
1952	Various models Air Over Hydraulic.....	N4105D	19				49
	Various models.....	376155	18				41
	Various models Air Over Hydraulic.....	375440	15				47
	Hydro-vac.....	374980	22				45
1951	Various models Air Over Hydraulic.....	N4105D	19				49
	Various models.....	376155	18				41
	Various models Air Over Hydraulic.....	375440	15				47
	Hydro-vac.....	374980	22				45
1950	Various models Air Over Hydraulic.....	N4105D	19				49
	Hydro-vac.....	374980	22				45
	Various models Air Over Hydraulic.....	375440	15				47
1949-48	Hydro-vac.....	374980	22				45
	Various models Air Over Hydraulic.....	N4105D	19				49
1947	Various models Air Over Hydraulic.....	N4105D	19				49
<b>F750 Conventional Cab</b>							
1977-72	w/single system Hydro-vac:						
	w/ 17.5M rear axle.....	2510065	25				34
	w/18.5M rear axle.....	2501350	24				33
	w/dual system Hydro-vac:						
1971-70	w/ 17.5M rear axle.....	2501350	24				33
	w/18.5M rear axle.....	2509558	24				34
	Various models.....	2508177	25				44
	Various models:						
1971-70	(has bracket on opposite side).....	2507224	38				35
	Various models:						
1969-68	(has bracket on opposite side).....	2507224	38				35
	w/single system Hydro-vac.....	2501350	24				33
	Various models.....	2500521	12				42
1967	w/single system Hydro-vac.....	2501350	24				33
	w/single Master Cyl. w/ Light Duty Hydro-vac.....	2501370	17				33
	Various models.....	2500521	12				42

**M  
E  
D  
I  
U  
M  
D  
U  
T  
Y  
A  
P  
P  
L  
I  
C  
A  
T  
I  
O  
N  
S**

# MEDIUM DUTY TRUCK APPLICATIONS



**M  
E  
D  
I  
U  
M  
D  
U  
T  
Y  
  
A  
P  
P  
L  
I  
C  
A  
T  
I  
O  
N  
S**

YEAR	FORD TRUCK CONT'D VEHICLE - MODEL	HYD VAC or P.S. & M.C.	Wt. Lbs	POWER SEC. w/o M.C.	Wt. Lbs	PEDAL ROD CODE	PICT. NO.
1966-64	w/single system Hydro-vac.....	2501350	24				33
	w/single Master Cyl. w/ Light Duty Hydro-vac.....	2501370	17				33
	Various models.....	2500521	12				42
	9500 lb - 16,000 lb GVW Field Inst.....	2500397	12				43
1963-62	w/single Master Cyl. w/ Light Duty Hydro-vac.....	2501370	17				33
	Various models Air Over Hydraulic.....	2501975	17				47
	Various models.....	2500521	12				42
	9500 lb - 16,000 lb GVW Field Inst.....	2500397	12				43
	Various models Air Over Hydraulic.....	N4105D	19				49
1961	Various models.....	2500521	12				42
	9500 lb - 16,000 lb GVW Field Inst.....	2500397	12				43
	Various models Air Over Hydraulic.....	N4105D	19				49
1960	9500 lb - 16,000 lb GVW Field Inst.....	2500397	12				43
	Various models Air Over Hydraulic.....	N4105D	19				49
1959-53	9500 lb - 16,000 lb GVW Field Inst.....	2500397	12				43
	Various models Air Over Hydraulic.....	375440	15				47
	Various models Air Over Hydraulic.....	N4105D	19				49
1952-50	Various models Air Over Hydraulic.....	375440	15				47
	Various models Air Over Hydraulic.....	N4105D	19				49
1949-47	Various models Air Over Hydraulic.....	N4105D	19				49
<b>FT750 Conventional Cab</b>							
1971-70	Various models.....	2508177	25				44
	Various models: (has bracket on opposite side).....	2507224	38				35
1969-68	Various models: (has bracket on opposite side).....	2507224	38				35
1967	w/single Master Cyl.: front axle unit.....	2501424	16				39
	rear axle unit.....	2501029	25				44
	Various models.....	2500521	12				42
1966-64	w/single Master Cyl.: front axle unit.....	2501424	16				40
	rear axle unit.....	2501029	25				44
	Various models.....	2500521	12				42
	9500 lb - 16,000 lb GVW Field Inst.....	2500397	12				43
1963-62	w/single Master Cyl.: front axle unit.....	2501424	16				40
	rear axle unit.....	2501029	25				44
	Various models.....	2500521	12				42
	Various models Air Over Hydraulic.....	2501975	17				47
	9500 lb - 16,000 lb GVW Field Inst.....	2500397	12				43
	Various models Air Over Hydraulic.....	N4105D	19				49
1961	Various models.....	2500521	12				42
	9500 lb - 16,000 lb GVW Field Inst.....	2500397	12				43
1961	Various models Air Over Hydraulic.....	N4105D	19				49
1960	9500 lb - 16,000 lb GVW Field Inst.....	2500397	12				43
	Various models Air Over Hydraulic.....	N4105D	19				49
1959-53	9500 lb - 16,000 lb GVW Field Inst.....	2500397	12				43
	Various models Air Over Hydraulic.....	375440	15				47
	Various models Air Over Hydraulic.....	N4105D	19				49
1952-50	Various models Air Over Hydraulic.....	375440	15				47
	Various models Air Over Hydraulic.....	N4105D	19				49
1949-47	Various models Air Over Hydraulic.....	N4105D	19				49

YEAR	FORD TRUCK CONT'D VEHICLE - MODEL	HYD VAC or P.S. & M.C.	Wt. Lbs	POWER SEC. w/o M.C.	Wt. Lbs	PEDAL ROD CODE	PICT. NO.
<b>F800 &amp; 8000 Conventional Cab</b>							
2020-97	Hydromax (casting # 2772114)..... Elec. Motor - stud type - 2771320 Elec. Motor - w/wire & pigtail - 2771420 Master Cylinder # 2379R			3700625	7 5 5		9 10 10
1996-84	Hydromax (casting # 2771293 / 2771371)..... Elec. Motor - stud type - 2771320 Elec. Motor - w/wire & pigtail - 2771420			3700273	7 5 5		9 10 10
1996-92	Master Cylinder # 2632R						
1991-84	Master Cylinder # 1999R						
1983-80	Hydromax (casting # 2771293 / 2771371)..... Elec. Motor - stud type - 2771320 Elec. Motor - w/wire & pigtail - 2771420			3700273	7 5 5		9 10 10
1982-80	Master Cylinder (single outlet) # 1909R						
1983	Master Cylinder (dual outlet) # 1992R						
	w/single system Hydro-vac..... w/ dual system Hydro-vac: (two units req'd)..... w/single Master Cyl. & Gas Engine.....	2510065 2510065 2509558	25 25 24				34 34 34
1982-80	w/single system Hydro-vac..... w/ dual system Hydro-vac: (two units req'd)..... w/single Master Cyl. & Gas Engine..... w/Hydro-max.....	2510065 2510065 2509558 2700278	25 25 24 18				34 34 34 9
1979-76	w/single system Hydro-vac..... w/dual system Hydro-vac: front axle unit..... rear axle unit.....	2501350 2509558 2501350	24 24 24				33 34 33
1971-70	Various models Various models: (has bracket on opposite side).....	2508177 2507224	25 38				44 35
1969-68	Various models: (has bracket on opposite side)..... w/dual system w/16x6" rear brk.: (two units req'd).....	2507224 2501350	38 24				35 33
1967	w/single Master Cyl.: front axle unit..... rear axle unit..... Various models.....	2501424 2501029 2500521	16 25 12				40 44 42
1966-64	w/single Master Cyl.: front axle unit..... rear axle unit..... Various models.....	2501424 2501029 2500521	16 25 12				40 44 42
1966-64	9500 lb - 16,000 lb GVW Field Inst..... Hydro-vac.....	2500397 374980	12 22				43 45
1963	w/single Master Cyl.: front axle unit..... rear axle unit..... Various models..... 9500 lb - 16,000 lb GVW Field Inst..... w/single system Hydro-vac..... Hydro-vac..... Various models Air Over Hydraulic.....	2501424 2501029 2500521 2500397 2501350 374980 2501975	16 25 12 12 24 22 17				40 44 42 43 33 45 47

**M  
E  
D  
I  
U  
M  
D  
U  
T  
Y  
A  
P  
P  
L  
I  
C  
A  
T  
I  
O  
N  
S**

# MEDIUM DUTY TRUCK APPLICATIONS



MEDIUM DUTY APPLICATIONS

YEAR	FORD TRUCK CONT'D VEHICLE - MODEL	HYD VAC or P.S. & M.C.	Wt. Lbs	POWER SEC. w/o M.C.	Wt. Lbs	PEDAL ROD CODE	PICT. NO.
1963	Various models Air Over Hydraulic.....	N4105D	19				49
1962	w/single Master Cyl.:						
	front axle unit.....	2501424	16				40
	rear axle unit.....	2501029	25				44
	Various models.....	2500521	12				42
	9500 lb - 16,000 lb GVW Field Inst.....	2500397	12				43
	Various models.....	376155	18				41
	Hydro-vac.....	374980	22				45
	Various models Air Over Hydraulic.....	2501975	17				47
	Various models Air Over Hydraulic.....	N4105D	19				49
1961	Various models.....	2500521	12				42
	9500 lb - 16,000 lb GVW Field Inst.....	2500397	12				43
	Various models.....	376155	18				41
	Hydro-vac.....	374980	22				45
	Various models Air Over Hydraulic.....	N4105D	19				49
1960	9500 lb - 16,000 lb GVW Field Inst.....	2500397	12				43
	Various models.....	376155	18				41
	Hydro-vac.....	374980	22				45
	Various models Air Over Hydraulic.....	N4105D	19				49
1959-53	9500 lb - 16,000 lb GVW Field Inst.....	2500397	12				43
	Various models.....	376155	18				41
	Various models Air Over Hydraulic.....	375440	15				47
	Hydro-vac.....	374980	22				45
	Various models Air Over Hydraulic.....	N4105D	19				49
1952-51	Various models.....	376155	18				41
	Various models Air Over Hydraulic.....	375440	15				47
	Hydro-vac.....	374980	22				45
	Various models Air Over Hydraulic.....	N4105D	19				49
1950	Various models Air Over Hydraulic.....	375440	15				47
	Hydro-vac.....	374980	22				45
	Various models Air Over Hydraulic.....	N4105D	19				49
1949-48	Hydro-vac.....	374980	22				45
	Various models Air Over Hydraulic.....	N4105D	19				49
1947	Various models Air Over Hydraulic.....	N4105D	19				49
<b>F850 Conventional Cab</b>							
1973-72	w/dual Master Cyl. Duo-Vac<10>.....	2509140	52				36
1971-70	Various models.....	2508177	25				44
	w/dual Master Cyl. Duo-Vac<10>.....	2509140	52				36
	Various models:						
	(has bracket on opposite side).....	2507224	38				35
	w/single Master Cyl.....	2501029	25				44
1969-68	w/dual Master Cyl. Duo-Vac<10>.....	2509140	52				36
	Various models:						
	(has bracket on opposite side).....	2507224	38				35
	w/single Master Cyl.....	2501029	25				44
1967	w/single Master Cyl.....	2501029	25				44
	Various models.....	2500521	12				42
1966-64	w/single Master Cyl.....	2501029	25				44
	Various models.....	2500521	12				42
	9500 lb - 16,000 lb GVW Field Inst.....	2500397	12				43
1963	w/single Master Cyl.....	2501029	25				44
	Various models Air Over Hydraulic.....	2501975	17				47
	Various models.....	2500521	12				42
	9500 lb - 16,000 lb GVW Field Inst.....	2500397	12				43
	Various models Air Over Hydraulic.....	N4105D	19				49

YEAR	FORD TRUCK CONT'D VEHICLE - MODEL	HYD VAC or P.S. & M.C.	Wt. Lbs	POWER SEC. w/o M.C.	Wt. Lbs	PEDAL ROD CODE	PICT. NO.
1962	w/single Master Cyl.....	2501029	25				44
	Various models Air Over Hydraulic.....	2501975	17				47
	Various models.....	2500521	12				42
	9500 lb - 16,000 lb GVW Field Inst.....	2500397	12				43
	Various models.....	376155	18				41
	Various models Air Over Hydraulic.....	N4105D	19				49
1961	Various models.....	2500521	12				42
	9500 lb - 16,000 lb GVW Field Inst.....	2500397	12				43
	Various models.....	376155	18				41
	Various models Air Over Hydraulic.....	N4105D	19				49
1960	9500 lb - 16,000 lb GVW Field Inst.....	2500397	12				43
	Various models.....	376155	18				41
	Various models Air Over Hydraulic.....	N4105D	19				49
1959-53	9500 lb - 16,000 lb GVW Field Inst.....	2500397	12				43
	Various models.....	376155	18				41
	Various models Air Over Hydraulic.....	375440	15				47
	Various models Air Over Hydraulic.....	N4105D	19				49
1952-51	Various models.....	376155	18				41
	Various models Air Over Hydraulic.....	375440	15				47
	Various models Air Over Hydraulic.....	N4105D	19				49
1950	Various models Air Over Hydraulic.....	375440	15				47
	Various models Air Over Hydraulic.....	N4105D	19				49
1949-47	Various models Air Over Hydraulic.....	N4105D	19				49
<b>FT800 Conventional Cab</b>							
1991-84	All.....	2700350	18	3700350	7		9
<b>FT850 Conventional Cab</b>							
1967	w/single Master Cyl.:						
	front axle unit.....	2501424	16				40
	rear axle unit.....	2501029	25				44
1966-64	w/single Master Cyl.:						
	front axle unit.....	2501424	16				40
	rear axle unit.....	2501029	25				44
	9500 lb - 16,000 lb GVW Field Inst.....	2500397	12				43
1963-62	w/single Master Cyl.:						
	front axle unit.....	2501424	16				40
	rear axle unit.....	2501029	25				44
	9500 lb - 16,000 lb GVW Field Inst.....	2500397	12				43
	Various models Air Over Hydraulic.....	N4105D	19				49
1961-60	9500 lb - 16,000 lb GVW Field Inst.....	2500397	12				43
	Various models Air Over Hydraulic.....	N4105D	19				49
1959-53	9500 lb - 16,000 lb GVW Field Inst.....	2500397	12				43
	Various models Air Over Hydraulic.....	375440	15				47
	Various models Air Over Hydraulic.....	N4105D	19				49
1952-50	Various models Air Over Hydraulic.....	375440	15				47
1952-50	Various models Air Over Hydraulic.....	N4105D	19				49
1949-47	Various models Air Over Hydraulic.....	N4105D	19				49
<b>F900 Conventional Cab</b>							
1971-68	w/single Master Cyl.....	2501350	24				33
1967	w/single Master Cyl.....	2501350	24				33
	Optional Air Over Hydraulic.....	375756	14				47
1966-64	w/single Master Cyl.....	2501350	24				33
	Optional Air Over Hydraulic.....	375756	14				47
	9500 lb - 16,000 lb GVW Field Inst.....	2500397	12				43

**M  
E  
D  
I  
U  
M  
D  
U  
T  
Y  
A  
P  
P  
L  
I  
C  
A  
T  
I  
O  
N  
S**

# MEDIUM DUTY TRUCK APPLICATIONS



MEDIUM DUTY TRUCK APPLICATIONS

YEAR	FORD TRUCK CONT'D VEHICLE - MODEL	HYD VAC or P.S. & M.C.	Wt. Lbs	POWER SEC. w/o M.C.	Wt. Lbs	PEDAL ROD CODE	PICT. NO.
1963-62	w/single Master Cyl.....	2501350	24				33
	Optional Air Over Hydraulic.....	375756	14				47
	9500 lb - 16,000 lb GVW Field Inst.....	2500397	12				43
	Various models Air Over Hydraulic.....	N4105D	19				49
1961-60	Optional Air Over Hydraulic.....	375756	14				47
	9500 lb - 16,000 lb GVW Field Inst.....	2500397	12				43
	Various models Air Over Hydraulic.....	N4105D	19				49
1959-54	Optional Air Over Hydraulic.....	375756	14				47
	9500 lb - 16,000 lb GVW Field Inst.....	2500397	12				43
	Hydro-vac.....	374750	25				46
	Various models Air Over Hydraulic.....	375440	15				47
	Various models Air Over Hydraulic.....	N4105D	19				49
1953	9500 lb - 16,000 lb GVW Field Inst.....	2500397	12				43
	Hydro-vac.....	374750	25				46
	Various models Air Over Hydraulic.....	375440	15				47
	Various models Air Over Hydraulic.....	N4105D	19				49
1952-50	Various models Air Over Hydraulic.....	375440	15				47
	Various models Air Over Hydraulic.....	N4105D	19				49
1949-47	Various models Air Over Hydraulic.....	N4105D	19				49
<b>LN500 Conventional Cab</b>							
1983-70	w/single Master Cyl. w/ 10 3/8 " pedal rod (firewall mount)<9>.....	C4085P	31	C4084H	20		8
	w/dual Master Cyl. w/ 10 3/8 " pedal rod (firewall mount)<9>.....	C4085M	31	C4084H	20		8
<b>LN600 Conventional Cab</b>							
2020-97	Hydromax (casting # 2772114).....			3700625	7		9
	Elec. Motor - stud type - 2771320				5		10
	Elec. Motor - w/wire & pigtail - 2771420				5		10
	Master Cylinder # 2379R						
1996-84	Hydromax (casting # 2771293 / 2771371).....			3700273	7		9
	Elec. Motor - stud type - 2771320				5		10
	Elec. Motor - w/ wire & pigtail - 2771420				5		10
1996-92	Master Cylinder # 2632R						
1991-84	Master Cylinder # 1999R						
1983-80	w/dual system Hydro-vac:						
	front axle unit.....	2509558	24				34
	rear axle unit.....	2501350	24				33
1979-70	w/dual system Hydro-vac:						
	front axle unit.....	2501350	24				33
	rear axle unit.....	2509558	24				34
<b>LN700 &amp; 7000 Conventional Cab</b>							
2020-97	Hydromax (casting # 2772114).....			3700625	7		9
	Elec. Motor - stud type - 2771320				5		10
	Elec. Motor - w/wire & pigtail - 2771420				5		10
	Master Cylinder # 2379R						
1996-84	Hydromax (casting # 2771293 / 2771371).....			3700273	7		9
	Elec. Motor - stud type - 2771320				5		10
	Elec. Motor - w/ wire & pigtail - 2771420				5		10
1996-92	Master Cylinder # 2632R						

YEAR	FORD TRUCK CONT'D VEHICLE - MODEL	HYD VAC or P.S. & M.C.	Wt. Lbs	POWER SEC. w/o M.C.	Wt. Lbs	PEDAL ROD CODE	PICT. NO.
1991-84	Master Cylinder # 1999R						
1983-80	w/dual system Hydro-vac:						
	front axle unit.....	2509558	24				34
	rear axle unit.....	2501350	24				33
1979-70	w/dual system Hydro-vac:						
	front axle unit.....	2501350	24				33
	rear axle unit.....	2509558	24				34
<b>LN750 Conventional Cab</b>							
1979-70	w/dual system Hydro-vac:						
	front axle unit.....	2509558	24				34
	rear axle unit.....	2501350	24				33
<b>L, LN800 &amp; 8000 Conventional Cab</b>							
2020-97	Hydromax (casting # 2772114).....			3700625	7		9
	Elec. Motor - stud type - 2771320				5		10
	Elec. Motor - w/wire & pigtail - 2771420				5		10
	Master Cylinder # 2379R						
1996-84	Hydromax (casting # 2771293 / 2771371).....			3700273	7		9
	Elec. Motor - stud type - 2771320				5		10
	Elec. Motor - w/ wire & pigtail - 2771420				5		10
1996-92	Master Cylinder # 2632R						
1991-84	Master Cylinder # 1999R						
1983-80	w/dual system Hydro-vac:						
	front axle unit.....	2509558	24				34
	rear axle unit.....	2501350	24				33
1979-70	w/dual system Hydro-vac:						
	front axle unit.....	2501350	24				33
	rear axle unit.....	2509558	24				34
	w/single system Hydro-vac.....	2510065	25				34
	w/single Master Cyl. (before S/N GG5,001).....	2509558	24				34
1979-77	w/single Master Cyl. (before S/N GG5,001).....	2509558	24				34
	w/dual system Hydro-vac:						
	front axle unit.....	2509558	24				34
	rear axle unit.....	2501350	24				33
1976-73	w/dual system Hydro-vac:						
	front axle unit.....	2509558	24				34
	rear axle unit.....	2501350	24				33
	w/single Master Cyl.....	2510065	25				34
1972	w/single Master Cyl.....	2510065	25				34
1972	w/single system Hydro-vac.....	2510065	25				34
	w/dual system Hydro-vac:						
	front axle unit.....	2501350	24				33
	rear axle unit.....	2509558	24				34
1971	w/dual system Hydro-vac:						
	front axle unit.....	2501350	24				33
	rear axle unit.....	2509558	24				34
<b>L, LN900 &amp; 9000 Conventional Cab</b>							
1983-77	w/single system Hydro-vac.....	2510065	25				34

# MEDIUM DUTY TRUCK APPLICATIONS



MEDIUM DUTY APPLICATIONS

YEAR	FORD TRUCK CONT'D VEHICLE - MODEL	HYD VAC or P.S. & M.C.	Wt. Lbs	POWER SEC. w/o M.C.	Wt. Lbs	PEDAL ROD CODE	PICT. NO.
1983-77	w/dual system Hydro-vac:						
	front axle unit.....	2510065	25				34
	rear axle unit.....	2501350	24				33
1976-73	w/single system Hydro-vac.....	2510065	25				34
	w/dual system Hydro-vac:						
	front axle unit.....	2510065	25				34
	rear axle unit.....	2501350	24				33
	w/single Master Cyl.	2510065	25				34
1972	w/single Master Cyl.	2510065	25				34

## LNT, LT, LTS800, 8000, 850, & 880 Tandem Conventional Cab

1995-84	Hydromax (casting # 2771293 / 2771371).....			3700273	7		9
	Elec. Motor - stud type - 2771320				5		10
	Elec. Motor - w/wire & pigtail - 2771420				5		10
1995-92	Master Cylinder # 1995R						
1991-84	Master Cylinder # 1999R						
1983-73	w/dual system Hydro-vac:						
	front axle unit.....	2509558	24				34
	rear axle unit.....	2501350	24				33
	w/tandem Hydro-vac.....	2509605	37				35
1972-71	w/tandem Hydro-vac.....	2509605	37				35
	w/dual system (two units req'd).....	2501350	24				33

## LT, LTS900 & 9000 Tandem Conventional Cab

1983-73	w/tandem Hydrovac.....	2509605	37				35
	w/dual system Hydro-vac:						
	front axle unit.....	2509558	24				34
	rear axle unit.....	2501350	24				33
	w/ dual system Hydro-vac: (two units req'd).....	2501350	24				33

## M Series- Motor Home

1980-76	M450/500 w/dual Master Cyl.: (two units req'd).....	2501350	24				33
1975-74	M400 8 cyl. Disc, (firewall mount).....	2700152	19	3700152	11		1
	M450/500 w/dual Master Cyl.: (two units req'd).....	2501350	24				33
	Various models 6 cyl. Disc, (firewall mount).....	2700151	19				2
1973	M450/500 w/dual Master Cyl.: (two units req'd).....	2501350	24				33
	Various models 6 cyl. Disc, (firewall mount).....	2700151	19				2

## N Series Short Conventional Cab

1977-74	N500/750 w/single Master Cyl. w/ 10 3/8 " pedal rod (firewall mount)<9>.....	C4085P	31	C4084H	20		8
	N500/750 w/dual Master Cyl. w/ 10 3/8 " pedal rod (firewall mount)<9>.....	C4085M	31	C4084H	20		8
	N500/750 w/single Master Cyl. w/ 10 3/8 " pedal rod (firewall mount)<9>.....	C4085P	31	C4084H	20		8
1973-72	N500/750 w/dual Master Cyl. w/ 10 3/8 " pedal rod (firewall mount)<9>.....	C4085M	31	C4084H	20		8

YEAR	FORD TRUCK CONT'D VEHICLE - MODEL	HYD VAC or P.S. & M.C.	Wt. Lbs	POWER SEC. w/o M.C.	Wt. Lbs	PEDAL ROD CODE	PICT. NO.
1973-72	N600/850 w/dual Master Cyl.<10>.....	2509140	52				36
	N6000/7000 Duo-vac.<10>.....	2509140	52				36
1971-69	N500/750 w/single Master Cyl. w/ 10 3/8 " pedal rod (firewall mount)<9>.....	C4085P	31	C4084H	20		8
	N500/750 w/dual Master Cyl. w/ 10 3/8 " pedal rod (firewall mount)<9>.....	C4085M	31	C4084H	20		8
	N600/850 w/dual Master Cyl.<10>.....	2509140	52				36
	N6000/7000 Duo-vac.<10>.....	2509140	52				36
	N800/850 w/single Master Cyl.....	2501029	25				44
	N500/900/6000 w/single Master Cyl.....	2501350	24				33
1968	N500/750 w/single Master Cyl. w/ 10 3/8 " pedal rod (firewall mount)<9>.....	C4085P	31	C4084H	20		8
	N500/750 w/dual Master Cyl. w/ 10 3/8 " pedal rod (firewall mount)<9>.....	C4085M	31	C4084H	20		8
	N600/850 w/dual Master Cyl.<10>.....	2509140	52				36
	N6000/7000 Duo-vac.<10>.....	2509140	52				36
	N500/700 w/ 10 1/4" pedal rod, (firewall mount).....	C4029	21	C4028A	14		6
	N500/700 w/ 7 1/8" pedal rod, (firewall mount).....	C4025E	16	C4026B3	12		6
	N600 w/ 10 1/4" pedal rod, (firewall mount).....	C4025F	18	C4026B6	12		6
	N800/850 w/single Master Cyl.....	2501029	25				44
1967-63	N500/700 w/ 10 1/4" pedal rod, (firewall mount).....	C4029	21	C4028A	14		6
	N500/700 w/ 7 1/8" pedal rod, (firewall mount).....	C4025E	16	C4026B3	12		6
	N600 w/ 10 1/4" pedal rod, (firewall mount).....	C4025F	18	C4026B6	12		6
	N750 w/single system Hydro-vac.....	2501350	24				33
	N800/850 w/single Master Cyl.....	2501029	25				44
	N500/900/6000 w/single Master Cyl.....	2501350	24				33
	N500/750 w/single Master Cyl.....	2501370	17				33
	N500/750 w/Light Duty Hydro-vac.....	2501370	17				33
1962	N850/900 w/single Master Cyl.: front axle unit.....	2501424	16				40
	rear axle unit.....	2501029	25				44
	N800/850 w/single Master Cyl.....	2501029	25				44
1962	N500/900/6000 w/single Master Cyl.....	2501350	24				33
	N500/750 w/single Master Cyl.....	2501370	17				33
	N500/750 w/Light Duty Hydro-vac.....	2501370	17				33
	N850/900 w/single Master Cyl.: front axle unit.....	2501424	16				40
	rear axle unit.....	2501029	25				44
<b>MISC. Models</b>							
1979-78	P600 w/single system Hydro-vac.....	2501350	24				33
1973-72	Various models (tandem dia.)<10>.....	2509149	52				36
1971-70	Various models.....	2508177	25				44
	Various models (tandem dia.)<10>.....	2509149	52				36
	Various models (tandem dia.).....	2507224	38				35
1969-68	Various models (tandem dia.)<10>.....	2509149	52				36
	Various models (tandem dia.).....	2507224	38				35
1967	DNT 850 (front axle unit).....	2501424	16				40
	DNT 850 (rear axle unit).....	2501029	25				44

<9> Customer Must Re-use Own Spacer Plate, Located On the Rear Can Over the Four Mounting Studs

<10> If Two Units, Use 2-2509558's

# MEDIUM DUTY TRUCK APPLICATIONS



**MEDIUM DUTY APPLICATIONS**

YEAR	FORD TRUCK CONT'D VEHICLE - MODEL	HYD VAC or P.S. & M.C.	Wt. Lbs	POWER SEC. w/o M.C.	Wt. Lbs	PEDAL ROD CODE	PICT. NO.
1967	T700-900 Optional Air Over Hydraulic.....	375756	14				47
1966-65	DNT 850 (front axle unit).....	2501424	16				40
	DNT 850 (rear axle unit).....	2501029	25				44
	T700-900 Optional Air Over Hydraulic.....	375756	14				47
	Various models 9500 lb to 16,000 lb GVW - Field Inst. Unit.....	2500397	12				43
1964	DNT 850 (front axle unit).....	2501424	16				40
	DNT 850 (rear axle unit).....	2501029	25				44
	T700-900 Optional Air Over Hydraulic.....	375756	14				47
	Various models 9500 lb to 16,000 lb GVW - Field Inst. Unit.....	2500397	12				43
	79T, 79TH, 79W, 79WH, 794T.....	374000	13				27
1963-62	DNT 850 (front axle unit).....	2501424	16				40
	DNT 850 (rear axle unit).....	2501029	25				44
	T700-900 Optional Air Over Hydraulic.....	375756	14				47
	Various models 9500 lb to 16,000 lb GVW - Field Inst. Unit.....	2500397	12				43
	P500/600 Hy-Power.....	C462	17				17
	79T, 79TH, 79W, 79WH, 794T.....	374000	13				27
1961-60	T750-800 (6-wheel).....	374229	47				46
	T700-900 Optional Air Over Hydraulic.....	375756	14				47
	Various models 9500 lb to 16,000 lb GVW - Field Inst. Unit.....	2500397	12				43
	P500/600 Hy-Power.....	C462	17				17
	79T, 79TH, 79W, 79WH, 794T.....	374000	13				27
1959-56	T700, C, F-900.....	374750	25				46
	T750-800 (6-wheel).....	374229	47				46
	T700-900 Optional Air Over Hydraulic.....	375756	14				47
	Various models 9500 lb to 16,000 lb GVW - Field Inst. Unit.....	2500397	12				43
	P500/600 Hy-Power.....	C462	17				17
	79T, 79TH, 79W, 79WH, 794T.....	374000	13				27
1955-54	T700-900 Optional Air Over Hydraulic.....	375756	14				47
	T800 (6-wheel).....	376658	47				46
	Various models 9500 lb to 16,000 lb GVW - Field Inst. Unit.....	2500397	12				43
	T700, C, F-900.....	374750	25				46
	P500/600 Hy-Power.....	C462	17				17
	79T, 79TH, 79W, 79WH, 794T.....	374000	13				27
1953	Various models 9500 lb to 16,000 lb GVW - Field Inst. Unit.....	2500397	12				43
	T700, C, F-900.....	374750	25				46
	P500/600 Hy-Power.....	C462	17				17
	79T, 79TH, 79W, 79WH, 794T.....	374000	13				27
1952	P500/600 Hy-Power.....	C462	17				17
	79T, 79TH, 79W, 79WH, 794T.....	374000	13				27
1951-47	79T, 79TH, 79W, 79WH, 794T.....	374000	13				27
<b>FREIGHTLINER</b>							
<b>MODELS FL50, 60, 70 &amp; MB60, 70, FS65, MT35, MT45</b>							
2020-92	Hydromax (casting # 2772114) Elec. Motor - stud type - 2771320 Master Cylinder (50.80 mm) # 2234RF			3700625	7 5		9 10

YEAR	VEHICLE - MODEL	HYD VAC or P.S. & M.C.	Wt. Lbs	POWER SEC. w/o M.C.	Wt. Lbs	PEDAL ROD CODE	PICT. NO.
<b>GMC TRUCKS</b>							
<b>MEDIUM DUTY</b>							
<b>VARIOUS MODELS</b>							
2020-97	All Hydomax (casting # 2772114)..... 2006-03 Elec. Motor - 2 wire plug - 2772729 2002-97 Elec. Motor - stud type - 2771320 2006-97 Master Cylinder Number - 2671R			<b>3700625</b>	7 5 5		9 10 10
1996-90	Delco Hy-Power - Casting # 18014765 w/ 7" Pedal Rod..... w/ 9" Pedal Rod..... Elec. Motor - with wire & pigtail - 6700974 Elec. Motor - with female plug - 6700975			<b>7700439</b> <b>7700556</b>	18 18		12 12 13 13
1989-88	Delco Hy-Power - casting # 2623435 w/ 7" Pedal Rod..... Elec. Motor - with wire & pigtail - 6700974 Elec. Motor - with female plug - 6700975			<b>7700439</b>	18		12 13 13
1987-85	Delco Hy-Power - casting # 2623435 w/ 7" Pedal Rod..... Elec. Motor - with wire & pigtail - 6700974 Elec. Motor - with female plug - 6700975			<b>7700439</b>	18		12 13 13
	Delco Dual Power (works w/ Vacuum & Power Steering Pump) : Hydraulic Section w/ Casting No. 2623501..... Vacuum Section w/ 5 1/4" Pedal Rod..... w/ 7" Pedal Rod.....			<b>7700435</b> <b>7700437</b> <b>7700436</b>	6 6 6		14 14 14
1984	Delco Hy-Power - casting # 2623435 w/ 7" Pedal Rod..... Elec. Motor - with wire & pigtail - 6700974 Elec. Motor - with female plug - 6700975			<b>7700439</b>	18		12 13 13
	Delco Dual Power (works w/ Vacuum & Power Steering Pump) : Hydraulic Section w/ Casting No. 2623501..... Vacuum Section w/ 5 1/4" Pedal Rod..... w/ 7" Pedal Rod.....			<b>7700435</b> <b>7700437</b> <b>7700436</b>	6 6 6		14 14 14
	50 Series w/ dual system Hydro-vac: (two units req'd).....	<b>2510027</b>	24				34
	Delco Dual Power (works w/ Vacuum & Power Steering Pump) : Hydraulic Section w/ Casting No. 2623501..... Vacuum Section: w/ 5 1/4" Pedal Rod..... w/ 7" Pedal Rod.....			<b>7700435</b> <b>7700437</b> <b>7700436</b>	6 6 6		14 14 14
	50 - 60 - 70 Series w/single dia. Unit.....	<b>2503139</b>	24				34
1983-77	50 Series w/ dual system Hydro-vac: (two units req'd).....	<b>2510027</b>	24				34
1983-77	Delco Dual Power (works w/ Vacuum & Power Steering Pump) : Hydraulic Section w/ Casting No. 2623501..... Vacuum Section: w/ 5 1/4" Pedal Rod..... w/ 7" Pedal Rod.....			<b>7700435</b> <b>7700437</b> <b>7700436</b>	6 6 6		14 14 14
	50 - 60 - 70 Series w/single dia. Unit.....	<b>2503139</b>	24				34
	60 - 70 - 80 Series w/Tandem dia. Unit.....	<b>2503123</b>	38				35

MEDIUM DUTY TRUCK APPLICATIONS



M  
E  
D  
I  
U  
M  
D  
U  
T  
Y  
A  
P  
P  
L  
I  
C  
A  
T  
I  
O  
N  
S

YEAR	GMC TRUCKS CONT'D VEHICLE - MODEL	HYD VAC or P.S. & M.C.	Wt. Lbs	POWER SEC. w/o M.C.	Wt. Lbs	PEDAL ROD CODE	PICT. NO.	
1976-74	Delco Dual Power (works w/ Vacuum & Power Steering Pump) :							
	Hydraulic Section w/ Casting No. 2623501.....			7700435	6		14	
	Vacuum Section: w/ 5 1/4" Pedal Rod.....			7700437	6		14	
	w/ 7" Pedal Rod.....			7700436	6		14	
	50 - 60 - 70 Series w/single dia. Unit.....	2503139	24				34	
60 - 70 - 80 Series w/Tandem dia. Unit.....	2503123	38				35		
1973-72	HG - HM7500V w/ 25,000 - 31,000 lb. GVW.....	C4042B	34				29	
	JG - JM7500V w/ 34,000 - 45,000 lb. GVW.....	C4036A	36				29	
	50 - 60 - 70 Series w/single dia. Unit.....	2503139	24				34	
	60 - 70 - 80 Series w/Tandem dia. Unit.....	2503123	38				35	
	1971	HG - HM7500V w/ 25,000 - 31,000 lb. GVW.....	C4042B	34				29
JG - JM7500V w/ 34,000 - 45,000 lb. GVW.....		C4036A	36				29	
TM7003 - TM - TG 7500V.....		C4058	35				30	
Various Models 500 - 600 Series w/ 11" Diameter Vacuum Chamber.....		2503151	24				34	
50 - 60 - 70 Series w/single dia. Unit.....		2503139	24				34	
60 - 70 - 80 Series w/Tandem dia. Unit.....		2503123	38				35	
1970		HG - HM7500V w/ 25,000 - 31,000 lb. GVW.....	C4042B	34				29
	JG - JM7500V w/ 34,000 - 45,000 lb. GVW.....	C4036A	36				29	
	TM7003 - TM - TG 7500V.....	C4058	35				30	
	Various Models 500 - 600 Series w/ 11" Diameter Vacuum Chamber.....	2503151	24				34	
	HG - HM5500V w/ 18,500 - 24,000 lb. GVW.....	C4035A	21				24	
	HG - HM5500V w/ 15,000 - 20,000 lb. GVW.....	C4034A	19				24	
	50 - 60 - 70 Series w/single dia. Unit.....	2503139	24				34	
	60 - 70 - 80 Series w/Tandem dia. Unit.....	2503123	38				35	
	1969	HG - HM7500V w/ 25,000 - 31,000 lb. GVW.....	C4042B	34				29
		JG - JM7500V w/ 34,000 - 45,000 lb. GVW.....	C4036A	36				29
TM7003 - TM - TG 7500V.....		C4058	35				30	
Various Models 500 - 600 Series w/ 11" Diameter Vacuum Chamber.....		2503151	24				34	
P - SM 5500 - M6500 - RM7500 w/ 19,000 lb. GVW.....		C4090	29				25	
School Bus, SM - SS - SG 5500 - SM6500, Firewall Mount:								
w/ 8 1/4" Pedal Rod.....		C4089G	31	C4084BJ	20		8	
w/13 1/2" Pedal Rod.....		C4089A	30	C4084BM	20		8	
HG - HM5500V w/ 18,500 - 24,000 lb. GVW.....		C4035A	21				24	
HG - HM5500V w/ 15,000 - 20,000 lb. GVW.....		C4034A	19				24	
50 - 60 - 70 Series w/single dia. Unit.....		2503139	24				34	
60 - 70 - 80 Series w/Tandem dia. Unit.....		2503123	38				35	
1968		HG - HM7500V w/ 25,000 - 31,000 lb.						

YEAR	GMC TRUCKS CONT'D VEHICLE - MODEL	HYD VAC or P.S. & M.C.	Wt. Lbs	POWER SEC. w/o M.C.	Wt. Lbs	PEDAL ROD CODE	PICT. NO.
1968	GVW.....	C4042B	34				29
	JG - JM7500V w/ 34,000 - 45,000 lb.						
	GVW.....	C4036A	36				29
	TM7003 - TM - TG 7500V.....	C4058	35				30
	Various Models 500 - 600 Series w/ 11" Diameter Vacuum Chamber.....	2503151	24				34
	EG - EM - ES5500V - 6500, Firewall Mount: w/13" Pedal Rod.....	C4074C	23	C4037NC	16		7
	EG - EM - ES4500V, Firewall Mount: w/ 8 " Pedal Rod.....	C4074A	23	C4037NA	16		7
	P - SM 5500 - M6500 - RM7500 w/ 19,000 lb. GVW.....	C4090	29				25
	School Bus, SM - SS - SG 5500 - SM6500, Firewall Mount: w/ 8 1/4" Pedal Rod.....	C4089G	31	C4084BJ	20		8
	w/13 1/2" Pedal Rod.....	C4089A	30	C4084BM	20		8
	HG - HM5500V w/ 18,500 - 24,000 lb. GVW.....	C4035A	21				24
	HG - HM5500V w/ 15,000 - 20,000 lb. GVW.....	C4034A	19				24
	50 - 60 - 70 Series w/single dia. Unit.....	2503139	24				34
60 - 70 - 80 Series w/Tandem dia. Unit.....	2503123	38				35	
1967	HG - HM7500V w/ 25,000 - 31,000 lb. GVW.....	C4042B	34				29
	JG - JM7500V w/ 34,000 - 45,000 lb. GVW.....	C4036A	36				29
	TM7003 - TM - TG 7500V.....	C4058	35				30
	Various Models 500 - 600 Series w/ 11" Diameter Vacuum Chamber.....	2503151	24				34
	EG - EM - ES5500V - 6500, Firewall Mount: w/13" Pedal Rod.....	C4074C	23	C4037NC	16		7
	EG - EM - ES4500V, Firewall Mount: w/ 8 " Pedal Rod.....	C4074A	23	C4037NA	16		7
	HG - HM5500V w/ 18,500 - 24,000 lb. GVW.....	C4035A	21				24
	HG - HM5500V w/ 15,000 - 20,000 lb. GVW.....	C4034A	19				24
	50 - 60 - 70 Series w/single dia. Unit.....	2503139	24				34
	60 - 70 - 80 Series w/Tandem dia. Unit.....	2503123	38				35
	Various Models Air Over Hydraulic.....	2504184	16				47
	Various Models Vacuum Over Hydraulic .....	2503151	24				34
	1966	HG - HM7500V w/ 25,000 - 31,000 lb. GVW.....	C4042B	34			
JG - JM7500V w/ 34,000 - 45,000 lb. GVW.....		C4036A	36				29
HG - HM5500V w/ 18,500 - 24,000 lb. GVW.....		C4035A	21				24
HG - HM5500V w/ 15,000 - 20,000 lb. GVW.....		C4034A	19				24
50 - 60 - 70 Series w/single dia. Unit.....		2503139	24				34
60 - 70 - 80 Series w/Tandem dia. Unit.....		2503123	38				35
Various Models Air Over Hydraulic.....		2504184	16				47
Various Models Vacuum Over Hydraulic .....		2503151	24				34
Various Models 500 - 600 Series							

**M  
E  
D  
I  
U  
M  
D  
U  
T  
Y  
A  
P  
P  
L  
I  
C  
A  
T  
I  
O  
N  
S**

# MEDIUM DUTY TRUCK APPLICATIONS



MEDIUM DUTY APPLICATIONS

YEAR	GMC TRUCKS CONT'D VEHICLE - MODEL	HYD VAC or P.S. & M.C.	Wt. Lbs	POWER SEC. w/o M.C.	Wt. Lbs	PEDAL ROD CODE	PICT. NO.	
1966	w/ 11" Diameter Vacuum Chamber.....	2501847	20				34	
	W-500.....	374750	25				46	
	1 1/2 Ton Over 8,800 to 16,000 lb.							
	GVW - Field Inst.....	2500397	12				43	
1965	50 - 60 - 70 Series w/single dia. Unit.....	2503139	24				34	
	60 - 70 - 80 Series w/Tandem dia. Unit.....	2503123	38				35	
	Various Models Vacuum Over Hydraulic .....	2503151	24				34	
	Various Models 40 - 50 Series, Air Over Hydraulic.....	2502062	17				47	
	Various Models 40 - 50 Series, Air Over Hydraulic.....	2502061	17				47	
	Various Models 500 - 600 Series w/ 11" Diameter Vacuum Chamber.....	2501847	20				34	
	Various Models w/ Gravity Flow Line from Master Cyl. Reservoir: w/ Single Dia.....	2503139	24				34	
	w/ Tandem Dia.....	2503123	38				35	
	SPV - BMV - LWV - 5000, LV - BV - BW - V5500, BV 6000.....	C4013	38				28	
	Used w/ C4013 on Tandem Axles.....	C4007	17				20	
	W-500.....	374750	25				46	
	1 1/2 Ton Over 8,800 to 16,000 lb.							
	GVW - Field Inst.....	2500397	12				43	
	1964	Various Models 40 - 50 Series, Air Over Hydraulic.....	2502062	17				47
		Various Models 40 - 50 Series, Air Over Hydraulic.....	2502061	17				47
		Various Models 500 - 600 Series w/ 11" Diameter Vacuum Chamber.....	2501847	20				34
Various Models w/ Gravity Flow Line from Master Cyl. Reservoir: w/ Single Dia.....		2503139	24				34	
w/ Tandem Dia.....		2503123	38				35	
SPV - BMV - LWV - 5000, LV - BV - BW - V5500, BV 6000.....		C4013	38				28	
Used w/ C4013 on Tandem Axles.....		C4007	17				20	
W-500.....		374750	25				46	
1 1/2 Ton Over 8,800 to 16,000 lb.								
GVW - Field Inst.....		2500397	12				43	
1963		Various Models 40 - 50 Series, Air Over Hydraulic.....	2502062	17				47
		Various Models 40 - 50 Series, Air Over Hydraulic.....	2502061	17				47
	Various Models 500 - 600 Series w/ 11" Diameter Vacuum Chamber.....	2501847	20				34	
	Various Models w/ Gravity Flow Line from Master Cyl. Reservoir: w/ Single Dia.....	2503139	24				34	
	w/ Tandem Dia.....	2503123	38				35	
	SPV - BMV - LWV - 5000, LV - BV - BW - V5500, BV 6000.....	C4013	38				28	
	Used w/ C4013 on Tandem Axles.....	C4007	17				20	

YEAR	GMC TRUCKS CONT'D VEHICLE - MODEL	HYD VAC or P.S. & M.C.	Wt. Lbs	POWER SEC. w/o M.C.	Wt. Lbs	PEDAL ROD CODE	PICT. NO.	
1963	W-500..... 1 1/2 Ton Over 8,800 to 16,000 lb.	374750	25				46	
	GVW - Field Inst.....	2500397	12				43	
	Various Models Air Over Hydraulic.....	375440	15				47	
1962	Various Models 500 - 600 Series w/ 11" Diameter Vacuum Chamber.....	2501847	20				34	
	Various Models w/ Gravity Flow Line from Master Cyl. Reservoir: w/ Single Dia.....	2503139	24				34	
	w/ Tandem Dia.....	2503123	38				35	
	SPV - BMV - LWV - 5000, LV - BV - BW - V5500, BV 6000.....	C4013	38				28	
	Used w/ C4013 on Tandem Axles.....	C4007	17				20	
	V3500V.....	C4003	18				18	
	V - BV - LV - SV - 4000 - 5000.....	C4012	21				23	
	Various Models Air Over Hydraulic.....	2500735	14				47	
	W-500.....	374750	25				46	
	1 1/2 Ton Over 8,800 to 16,000 lb. GVW - Field Inst.....	2500397	12				43	
	Various Models Air Over Hydraulic.....	375440	15				47	
	Field Inst. Air Over Hydraulic.....	N4105D	19				49	
	1961-60	SPV - BMV - LWV - 5000, LV - BV - BW - V5500, BV 6000.....	C4013	38				28
Used w/ C4013 on Tandem Axles.....		C4007	17				20	
V3500V.....		C4003	18				18	
V - BV - LV - SV - 4000 - 5000.....		C4012	21				23	
Various Models Air Over Hydraulic.....		375901	14				47	
Various Models Air Over Hydraulic.....		375756	14				47	
Various Models Air Over Hydraulic.....		2500735	14				47	
W-500.....		374750	25				46	
1 1/2 Ton Over 8,800 to 16,000 lb. GVW - Field Inst.....		2500397	12				43	
Various Models Air Over Hydraulic.....		375440	15				47	
Field Inst. Air Over Hydraulic.....		N4105D	19				49	
1959		V - BV - LV - SV - 4000 - 5000.....	C4012	21				23
		Various Models Air Over Hydraulic.....	2500735	14				47
	W-500.....	374750	25				46	
	37 - F37.....	C464	20				22	
	1 1/2 Ton Over 8,800 to 16,000 lb. GVW - Field Inst.....	2500397	12				43	
	Various Models Air Over Hydraulic.....	375440	15				47	
	450 - 720 Series.....	374750	25				46	
	Field Inst. Air Over Hydraulic.....	N4105D	19				49	
1958	Various Models Air Over Hydraulic.....	2500735	14				47	
	W-500.....	374750	25				46	
	37 - F37.....	C464	20				22	
	1 1/2 Ton Over 8,800 to 16,000 lb. GVW - Field Inst.....	2500397	12				43	
	Various Models Air Over Hydraulic.....	375440	15				47	
	450 - 720 Series.....	374750	25				46	
	Field Inst. Air Over Hydraulic.....	N4105D	19				49	
	450 Series.....	373853	22				45	
1957-56	W-500.....	374750	25				46	
	400 - 450 - 470 - 500.....	374980	22				45	
	2 1/2 Ton (6 x 6 Ordinance) Air Over Hydraulic.....	376440	15				47	

# MEDIUM DUTY TRUCK APPLICATIONS



MEDIUM DUTY APPLICATIONS

YEAR	GMC TRUCKS CONT'D VEHICLE - MODEL	HYD VAC or P.S. & M.C.	Wt. Lbs	POWER SEC. w/o M.C.	Wt. Lbs	PEDAL ROD CODE	PICT. NO.
1957-56	1 1/2 Ton Over 8,800 to 16,000 lb. GVW - Field Inst.....	2500397	12				43
	Various Models Air Over Hydraulic.....	375440	15				47
	450 - 720 Series.....	374750	25				46
	Field Inst. Air Over Hydraulic.....	N4105D	19				49
	450 Series.....	373853	22				45
1955-54	400 - 450 - 470 - 500.....	374980	22				45
	2 1/2 Ton (6 x 6 Ordinance) Air Over Hydraulic.....	376440	15				47
	1 1/2 Ton Over 8,800 to 16,000 lb. GVW - Field Inst.....	2500397	12				43
	Various Models Air Over Hydraulic.....	375440	15				47
	450 - 720 Series.....	374750	25				46
	Field Inst. Air Over Hydraulic.....	N4105D	19				49
	450 Series.....	373853	22				45
1953	400 - 450 - 470 - 500.....	374980	22				45
	2 1/2 Ton (6 x 6 Ordinance) Air Over Hydraulic.....	376440	15				47
	1 1/2 Ton Over 8,800 to 16,000 lb. GVW - Field Inst.....	2500397	12				43
	Various Models Air Over Hydraulic.....	375440	15				47
	450 - 720 Series.....	374750	25				46
	Field Inst. Air Over Hydraulic.....	N4105D	19				49
	450 Series.....	373853	22				45
1952	1 1/2 Ton Over 8,800 to 16,000 lb. GVW - Field Inst.....	2500397	12				43
	Various Models Air Over Hydraulic.....	375440	15				47
	Field Inst. Air Over Hydraulic.....	N4105D	19				49
	450 Series.....	373853	22				45
	450 - 720 Series.....	374750	25				46
1951-50	Various Models Air Over Hydraulic.....	375440	15				47
	Field Inst. Air Over Hydraulic.....	N4105D	19				49
	450 Series.....	373853	22				45
	450 - 720 Series.....	374750	25				46
1949	Field Inst. Air Over Hydraulic.....	N4105D	19				49
	450 Series.....	373853	22				45
	450 - 720 Series.....	374750	25				46
1948-47	Field Inst. Air Over Hydraulic.....	N4105D	19				49
	450 Series.....	373853	22				45
1946	Various Models 280 - 410 Series.....	374000	13				27
	450 Series.....	373853	22				45
1945	450 Series.....	373853	22				45

## HYSTER EQUIPMENT

### VARIOUS MODELS

1982-79	Various Models.....	374980	22				45
1978-62	Various Models.....	374000	13				43
	Various Models.....	374980	22				45
1961-51	Various Models.....	374980	22				45

## IHC/NAVISTAR TRUCK

### MEDIUM DUTY

#### 1000 SERIES

2020-96	452FC, 1652FC & 1154FC, M1400 & 1600						
	Hydromax (casting # 2772114).....			3700625	7		9
	Elec. Motor - stud type - 2771320				5		10

YEAR	IHC/NAVISTAR TRUCK CONT'D VEHICLE - MODEL	HYD VAC or P.S. & M.C.	Wt. Lbs	POWER SEC. w/o M.C.	Wt. Lbs	PEDAL ROD CODE	PICT. NO.
2020-96	Elec. Motor - w/wire & pigtail - 2771420 Master Cylinder (50.80mm) # 2379R				5		10
1995-87	Hydromax (casting # 2771424)..... Elec. Motor - w/wire & pigtail - 2771420 Master Cylinder (ups model only) # 2339R Master Cylinder (all other models) # 2379R			3700394	7 5		9 10
1987	1652SC Delco Hypower (casting # 2623435 - 5 1/2 Rod)..... Elec. Motor - w/wire & pigtail - 6700974 Master Cylinder (2" bore) # 1994R			7700438			
<b>3000 SERIES</b>							
2020-98	3600, 3700, 3800 & 3900 - FC School Bus Hydromax (casting # 2772114)..... Elec. Motor - stud type - 2771320 Elec. Motor - w/wire & pigtail - 2771420 Master Cylinder (50.80mm) # 2379R			3700625	7 5 5		9 10 10
1997-90	Hydromax (casting # 2771424)..... Elec. Motor - w/wire & pigtail - 2771420 Master Cylinder (50.80mm) # 2379R			3700394	7 5		9 10
<b>4000 SERIES</b>							
2020-98	4600, LP-UH, 4700LP, 4800 & 4900 Hydromax (casting # 2772114)..... Elec. Motor - stud type - 2771320 Elec. Motor - w/wire & pigtail - 2771420 Master Cylinder (50.80mm) # 2379R			3700625	7 5 5		9 10 10
1997-90	Hydromax (casting # 2771424)..... Elec. Motor - w/wire & pigtail - 2771420 Master Cylinder (50.80mm) # 2379R			3700394	7 5		9 10
<b>7000 SERIES</b>							
2020-98	4600, LP-UH, 4700LP, 4800 & 4900 Hydromax (casting # 2772114)..... Elec. Motor - stud type - 2771320 Elec. Motor - w/wire & pigtail - 2771420 Master Cylinder (50.80mm) # 2379R			3700625	7 5 5		9 10 10
1995-90	7100 Hydromax (casting # 2771424)..... Elec. Motor - w/wire & pigtail - 2771420 Master Cylinder (50.80mm) # 2379R			3700394	7 5		9 10
<b>EARLIER MODELS</b>							
1990-78	Various Heavy Duty - Motor Home - Bus Delco Hypower w/ Casting # 18015765 (9" Pedal Rod).....			7700556			
1987	1652SC						
1987	Delco Hypower w/ Casting # 2623435 - 5 1/2" Rod)..... Elec. Motor - w/wire & pigtail - 6700974 Master Cylinder (2" bore) # 1994R			7700438			
	Delco Dual Power Hydraulic Section (casting # 2623501)..... Vacuum Section:			7700435			

# MEDIUM DUTY TRUCK APPLICATIONS



MEDIUM DUTY APPLICATIONS

YEAR	IHC/NAVISTAR TRUCK CONT'D VEHICLE - MODEL	HYD VAC or P.S. & M.C.	Wt. Lbs	POWER SEC. w/o M.C.	Wt. Lbs	PEDAL ROD CODE	PICT. NO.
1987	w/ 5 1/4" Pedal Rod.....			7700437	6		14
	w/ 7" Pedal Rod.....			7700436	6		14
1986	1650B - 1710A - 1750B - 1810A - 1830A - 1850B - Hydro Max Booster.....	2700351	18	3700350	7		9
	Delco Hy-Power w/ Casting # 18015765 (9" Pedal Rod)..... w/ Casting # 2623435 (5 1/2" Pedal Rod).....			7700556 7700438			
	Delco Dual Power Hydraulic Section (casting # 2623501)..... Vacuum Section:			7700435			
	w/ 5 1/4" Pedal Rod.....			7700437	6		14
	w/ 7" Pedal Rod.....			7700436	6		14
1985	1650B - 1710A - 1750B - 1810A - 1830A - 1850B - Hydro Max Booster.....	2700351	18	3700350	7		9
	Delco Hy-Power w/ Casting # 18015765 (9" Pedal Rod)..... w/ Casting # 2623435 (5 1/2" Pedal Rod).....			7700556 7700438	18 18		12 12
	Delco Dual Power Hydraulic Section (casting # 2623501)..... Vacuum Section:			7700435	6		14
	w/ 5 1/4" Pedal Rod.....			7700437	6		14
	w/ 7" Pedal Rod.....			7700436	6		14
1984	1650B - 1710A - 1750B - 1810A - 1830A - 1850B - Hydro Max Booster.....	2700351	18	3700350	7		9
	1600 - 1700 - 1800 - 1900 Series w/o Residual Check Valve.....	2513494	23				33
	1600 - 1700 - 1800 - 1900 Series w/ Residual Check Valve.....	2513492	23				33
	Delco Hy-Power w/ Casting # 18015765 (9" Pedal Rod)..... w/ Casting # 2623435 (5 1/2" Pedal Rod).....			7700556 7700438	18 18		12 12
	Delco Dual Power Hydraulic Section (casting # 2623501)..... Vacuum Section:			7700435	6		14
	w/ 5 1/4" Pedal Rod..... w/ 7" Pedal Rod.....			7700437 7700436	6 6		14 14
1983-82	1600 - 1700 - 1800 - 1900 Series w/o Residual Check Valve.....	2513494	23				33
	1600 - 1700 - 1800 - 1900 Series w/ Residual Check Valve.....	2513492	23				33
	Delco Hy-Power w/ Casting # 18015765 (9" Pedal Rod)..... w/ Casting # 2623435 (5 1/2" Pedal Rod).....			7700556 7700438	18 18		12 12
	Delco Dual Power Hydraulic Section (casting # 2623501)..... Vacuum Section:			7700435	6		14
	w/ 5 1/4" Pedal Rod..... w/ 7" Pedal Rod.....			7700437 7700436	6 6		14 14
	1981	1600 - 1700 - 1800 - 1900 Series w/o Residual Check Valve.....	2513494	23			
1600 - 1700 - 1800 - 1900 Series w/ Residual Check Valve.....		2513492	23				33
1800 - 1900 - 2000 Series w/ Tandem Dia. Booster.....		2513493	37				33
Delco Hy-Power w/ Casting # 18015765 (9" Pedal Rod).....				7700556	18		12

YEAR	IHC/NAVISTAR TRUCK CONT'D VEHICLE - MODEL	HYD VAC or P.S. & M.C.	Wt. Lbs	POWER SEC. w/o M.C.	Wt. Lbs	PEDAL ROD CODE	PICT. NO.
1981	w/ Casting # 2623435 (5 1/2" Pedal Rod).....			7700438	18		12
	Delco Dual Power Hydraulic Section (casting # 2623501).....			7700435	6		14
	Vacuum Section: w/ 5 1/4" Pedal Rod.....			7700437	6		14
	w/ 7" Pedal Rod.....			7700436	6		14
1980-79	1600 - 1610 - 1810 - 1890 Series Loadstar w/ Residual Check Valve.....	2510296	23				33
	1800 - 1900 - 2000 Series w/ Tandem Dia. Booster.....	2508065	36				35
	1600 - 1700 - 1800 Series Loadstar, w/o Residual Check Valve.....	2502982	23				48
	Delco Hy-Power w/ Casting # 18015765 (9" Pedal Rod).....			7700556	18		12
	w/ Casting # 2623435 (5 1/2" Pedal Rod).....			7700438	18		12
	Delco Dual Power Hydraulic Section (casting # 2623501).....			7700435	6		14
	Vacuum Section: w/ 5 1/4" Pedal Rod.....			7700437	6		14
	w/ 7" Pedal Rod.....			7700436	6		14
1978	1600 - 1610 - 1810 - 1890 Series Loadstar w/ Residual Check Valve.....	2510296	23				33
	1600 Series Loadstar w/ Residual Check Valve.....	2508819	23				33
	1800 - 1900 - 2000 Series w/ Tandem Dia. Booster.....	2508065	36				35
	1600 - 1700 - 1800 Series School Bus.....	2508059	25				34
	1600 - 1700 - 1800 Series Loadstar, w/o Residual Check Valve.....	2502982	23				48
	Delco Hy-Power w/ Casting # 18015765 (9" Pedal Rod).....			7700556	18		12
	w/ Casting # 2623435 (5 1/2" Pedal Rod).....			7700438	18		12
	Delco Dual Power Hydraulic Section (casting # 2623501).....			7700435	6		14
Vacuum Section: w/ 5 1/4" Pedal Rod.....			7700437	6		14	
w/ 7" Pedal Rod.....			7700436	6		14	
1977	Delco Dual Power Hydraulic Section (casting # 2623501).....			7700435	6		14
	Vacuum Section: w/ 5 1/4" Pedal Rod.....			7700437	6		14
	w/ 7" Pedal Rod.....			7700436	6		14
	1600 - 1610 - 1810 - 1890 Series Loadstar w/ Residual Check Valve.....	2510296	23				33
	1600 Series Loadstar w/ Residual Check Valve.....	2508819	23				33
	1603 Series Bus (firewall mount).....	C4089B	31	C4084C	20		8
	1800 - 1900 - 2000 Series w/ Tandem Dia. Booster.....	2508065	36				35
	1600 - 1700 - 1800 Series School Bus.....	2508059	25				34
1500 Series (firewall mount).....	C4072D	26	C4044KD	13		7	
1600 - 1700 - 1800 Series Loadstar, w/o Residual Check Valve.....	2502982	23				48	
1976	Delco Dual Power Hydraulic Section (casting # 2623501).....			7700435	6		14

**M  
E  
D  
I  
U  
M  
D  
U  
T  
Y  
A  
P  
P  
L  
I  
C  
A  
T  
I  
O  
N  
S**

# MEDIUM DUTY TRUCK APPLICATIONS



MEDIUM DUTY APPLICATIONS

YEAR	IHC/NAVISTAR TRUCK CONT'D VEHICLE - MODEL	HYD VAC or P.S. & M.C.	Wt. Lbs	POWER SEC. w/o M.C.	Wt. Lbs	PEDAL ROD CODE	PICT. NO.
1976	Vacuum Section: w/ 5 1/4" Pedal Rod.....			7700437	6		14
	w/ 7" Pedal Rod.....			7700436	6		14
	Drum Multi-Stop 1510 (firewall mount).....	C4073A	25	C4044KA	13		7
	1600 - 1610 - 1810 - 1890 Series Loadstar w/ Residual Check Valve.....	2510296	23				33
	1600 Series Loadstar w/ Residual Check Valve.....	2508819	23				33
	1603 Series Bus (firewall mount).....	C4089B	31	C4084C	20		8
	1800 - 1900 - 2000 Series w/ Tandem Dia. Booster.....	2508065	36				35
	1600 - 1700 - 1800 Series School Bus.....	2508059	25				34
	1500 Series (firewall mount).....	C4072D	26	C4044KD	13		7
	1600 - 1700 - 1800 Series Loadstar, w/o Residual Check Valve.....	2502982	23				48
1975	Delco Dual Power Hydraulic Section (casting # 2623501).....			7700435	6		14
	Vacuum Section: w/ 5 1/4" Pedal Rod.....			7700437	6		14
	w/ 7" Pedal Rod.....			7700436	6		14
	Drum Multi-Stop 1510 (firewall mount).....	C4073A	25	C4044KA	13		7
	1600 - 1610 - 1810 - 1890 Series Loadstar w/ Residual Check Valve.....	2510296	23				33
	Drum Motor Home (firewall mount).....	2509768	17	3509768	11	IH8	1
	1600 Series Loadstar w/ Residual Check Valve.....	2508819	23				33
	1603 Series Bus (firewall mount).....	C4089B	31	C4084C	20		8
	1800 - 1900 - 2000 Series w/ Tandem Dia. Booster.....	2508065	36				35
	1600 - 1700 - 1800 Series School Bus.....	2508059	25				34
1974	Delco Dual Power Hydraulic Section (casting # 2623501).....			7700435	6		14
	Vacuum Section: w/ 5 1/4" Pedal Rod.....			7700437	6		14
	w/ 7" Pedal Rod.....			7700436	6		14
	Drum Multi-Stop 1510 (firewall mount).....	C4073A	25	C4044KA	13		7
	1600 - 1610 - 1810 - 1890 Series Loadstar w/ Residual Check Valve.....	2510296	23				33
	Drum Motor Home (firewall mount).....	2509768	17	3509768	11	IH8	1
	1600 Series Loadstar w/ Residual Check Valve.....	2508819	23				33
	1603 Series Bus (firewall mount).....	C4089B	31	C4084C	20		8
	1800 - 1900 - 2000 Series w/ Tandem Dia. Booster.....	2508065	36				35
	1600 - 1700 - 1800 Series School Bus.....	2508059	25				34
1973	Delco Dual Power Hydraulic Section (casting # 2623501).....			7700435	6		14
	Vacuum Section: w/ 5 1/4" Pedal Rod.....			7700437	6		14
	w/ 7" Pedal Rod.....			7700436	6		14
	Drum Multi-Stop 1510 (firewall mount).....	C4073A	25	C4044KA	13		7
	1600 - 1610 - 1810 - 1890 Series Loadstar w/ Residual Check Valve.....	2510296	23				33
	Drum Motor Home (firewall mount).....	2509768	17	3509768	11	IH8	1
	1600 Series Loadstar w/ Residual Check Valve.....	2508819	23				33
	1603 Series Bus (firewall mount).....	C4089B	31	C4084C	20		8
	1800 - 1900 - 2000 Series w/ Tandem Dia. Booster.....	2508065	36				35
	1600 - 1700 - 1800 Series School Bus.....	2508059	25				34

YEAR	IHC/NAVISTAR TRUCK CONT'D VEHICLE - MODEL	HYD VAC or P.S. & M.C.	Wt. Lbs	POWER SEC. w/o M.C.	Wt. Lbs	PEDAL ROD CODE	PICT. NO.	
1973	Drum Multi-Stop 1510 (firewall mount).....	<b>C4073A</b>	25	<b>C4044KA</b>	13		7	
	1600 - 1610 - 1810 - 1890 Series Loadstar w/ Residual Check Valve.....	<b>2510296</b>	23				33	
	Drum Motor Home (firewall mount).....	<b>2509768</b>	17	<b>3509768</b>	11	IH8	1	
	1600 Series Loadstar w/ Residual Check Valve.....	<b>2508819</b>	23				33	
	1603 Series Bus (firewall mount).....	<b>C4089B</b>	31	<b>C4084C</b>	20		8	
	1800 - 1900 - 2000 Series w/ Tandem Dia. Booster.....	<b>2508065</b>	36				35	
	1600 - 1700 - 1800 Series School Bus.....	<b>2508059</b>	25				34	
	1500 Series (firewall mount).....	<b>C4072D</b>	26	<b>C4044KD</b>	13		7	
	1600 - 1700 - 1800 Series Loadstar, w/o Residual Check Valve.....	<b>2502982</b>	23				48	
	1500 Series Motor Home.....	<b>2502119</b>	14				39	
1972	1600 - 1610 - 1810 - 1890 Series Loadstar w/ Residual Check Valve.....	<b>2510296</b>	23				33	
	Drum Motor Home (firewall mount).....	<b>2509768</b>	17	<b>3509768</b>	11	IH8	1	
	1600 Series Loadstar w/ Residual Check Valve.....	<b>2508819</b>	23				33	
	1603 Series Bus (firewall mount).....	<b>C4089B</b>	31	<b>C4084C</b>	20		8	
	1800 - 1900 - 2000 Series w/ Tandem Dia. Booster.....	<b>2508065</b>	36				35	
	1600 - 1700 - 1800 Series School Bus.....	<b>2508059</b>	25				34	
	1500 Series (firewall mount).....	<b>C4072D</b>	26	<b>C4044KD</b>	13		7	
	1600 - 1700 - 1800 Series Loadstar, w/o Residual Check Valve.....	<b>2502982</b>	23				48	
	1500 Series Motor Home.....	<b>2502119</b>	14				39	
	1971-69	1600 Series Loadstar w/ Residual Check Valve.....	<b>2508819</b>	23				33
1603 Series Bus (firewall mount).....		<b>C4089B</b>	31	<b>C4084C</b>	20		8	
1800 - 1900 - 2000 Series w/ Tandem Dia. Booster.....		<b>2508065</b>	36				35	
1600 - 1700 - 1800 Series School Bus.....		<b>2508059</b>	25				34	
1500 Series (firewall mount).....		<b>C4072D</b>	26	<b>C4044KD</b>	13		7	
1600 - 1700 - 1800 Series Loadstar, C0190 - 8190.....		<b>374750</b>	25				46	
Metro 1400 - 1500 Series.....		<b>2501847</b>	20				34	
1600 - 1700 - 1800 Series Loadstar, w/o Residual Check Valve.....		<b>2502982</b>	23				48	
1500 Series Motor Home.....		<b>2502119</b>	14				39	
Various Models 190 - 200 - 1800 - 1850 - 2010 - 2050 Series.....		<b>374230</b>	52	CALL	FOR	AVAILABILITY		
Various Models 170 - 180 - 190 - 1800 - 1850 Series.....		<b>374229</b>	47	CALL	FOR	AVAILABILITY		
1968		1800 - 1900 - 2000 Series w/ Tandem Dia. Booster.....	<b>2508065</b>	36				35
		1600 - 1700 - 1800 Series School Bus.....	<b>2508059</b>	25				34
	1500 Series (firewall mount).....	<b>C4072D</b>	26	<b>C4044KD</b>	13		7	
	1600 - 1700 - 1800 Series Loadstar, C0190 - 8190.....	<b>374750</b>	25				46	
	Metro 1400 - 1500 Series.....	<b>2501847</b>	20				34	
	1600 - 1700 - 1800 Series Loadstar, w/o Residual Check Valve.....	<b>2502982</b>	23				48	
	1500 Series Motor Home.....	<b>2502119</b>	14				39	
	Various Models 190 - 200 - 1800 - 1850 - 2010 - 2050 Series.....	<b>374230</b>	52	CALL	FOR	AVAILABILITY		

**M  
E  
D  
I  
U  
M  
D  
U  
T  
Y  
A  
P  
P  
L  
I  
C  
A  
T  
I  
O  
N  
S**

# MEDIUM DUTY TRUCK APPLICATIONS



MEDIUM DUTY APPLICATIONS

YEAR	IHC/NAVISTAR TRUCK CONT'D VEHICLE - MODEL	HYD VAC or P.S. & M.C.	Wt. Lbs	POWER SEC. w/o M.C.	Wt. Lbs	PEDAL ROD CODE	PICT. NO.
1968	Various Models 170 - 180 - 190 - 1800 - 1850 Series.....	374229	47	CALL	FOR	AVAILABILITY	
1967	2010A - 2050A Fleet Star w/ Tandem Booster.....	2506209	37				35
	1600 - 1700 - 1800 Series Loadstar, C0190 - 8190.....	374750	25				46
	Metro 1400 - 1500 Series.....	2501847	20				34
	1900 - 2000 Series (Clutch Assist).....	2503230	9				48
	1600 - 1700 - 1800 Series Loadstar, w/o Residual Check Valve.....	2502982	23				48
	1500 Series Motor Home.....	2502119	14				39
	RF190, VF190 Opt. Air Over Hydraulic.....	375756	14				47
	Various Models 160 - 170 - 180 - 185 Series Opt. Air Over Hydraulic.....	375757	16				47
	Various Models 160 - 170 - 180 - 185 Series.....	375680	17				41
	Various Models 190 - 200 - 1800 - 1850 - 2010 - 2050 Series.....	374230	52	CALL	FOR	AVAILABILITY	
	Various Models 170 - 180 - 190 - 1800 - 1850 Series.....	374229	47	CALL	FOR	AVAILABILITY	
1966	1600 - 1700 - 1800 Series Loadstar, C0190 - 8190.....	374750	25				46
	Metro 1400 - 1500 Series.....	2501847	20				34
	M - MC 1600 - 1700 Series.....	2504188	24				34
	1900 - 2000 Series (Clutch Assist).....	2503230	9				48
	1600 - 1700 - 1800 Series Loadstar, w/o Residual Check Valve.....	2502982	23				48
	1500 Series Motor Home.....	2502119	14				39
	RF190, VF190 Opt. Air Over Hydraulic.....	375756	14				47
	Various Models 160 - 170 - 180 - 185 Series Opt. Air Over Hydraulic.....	375757	16				47
	Various Models 160 - 170 - 180 - 185 Series.....	375680	17				41
	Various Models 190 - 200 - 1800 - 1850 - 2010 - 2050 Series.....	374230	52	CALL	FOR	AVAILABILITY	
	Various Models 170 - 180 - 190 - 1800 - 1850 Series.....	374229	47	CALL	FOR	AVAILABILITY	
1965	1600 - 1700 - 1800 Series Loadstar, C0190 - 8190.....	374750	25				46
	Metro 1400 - 1500 Series.....	2501847	20				34
	M - MC 1600 - 1700 Series.....	2504188	24				34
	1900 - 2000 Series (Clutch Assist).....	2503230	9				48
	1600 - 1700 - 1800 Series Loadstar, w/o Residual Check Valve.....	2502982	23				48
	1500 Series Motor Home.....	2502119	14				39
	Various Models.....	2502703	25				44
	Various Models.....	2502982	24				33
	Various Metro Models.....	378804	13				43
	RF190, VF190 Opt. Air Over Hydraulic.....	375756	14				47
	Various Models 160 - 170 - 180 - 185 Series Opt. Air Over Hydraulic.....	375757	16				47
	Various Models Air Over Hydraulic.....	375844	15				47
	Various Models 160 - 170 - 180 - 185 Series.....	375680	17				41
	Various Models 190 - 200 - 1800 - 1850 - 2010 - 2050 Series.....	374230	52	CALL	FOR	AVAILABILITY	

YEAR	IHC/NAVISTAR TRUCK CONT'D VEHICLE - MODEL	HYD VAC or P.S. & M.C.	Wt. Lbs	POWER SEC. w/o M.C.	Wt. Lbs	PEDAL ROD CODE	PICT. NO.	
1965	Various Models 170 - 180 - 190 - 1800 - 1850 Series.....	374229	47	CALL	FOR	AVAILABILITY		
	1964	1900 - 2000 Series (Clutch Assist).....	2503230	9			48	
1964	1600 - 1700 - 1800 Series Loadstar, w/o Residual Check Valve.....	2502982	23				48	
	1500 Series Motor Home.....	2502119	14				39	
	Various Models.....	2502703	25				44	
	Various Models.....	2502982	24				33	
	Various Metro Models.....	378804	13				43	
	CO 4000 (Clutch Assist).....	2500187	9				48	
	RF190, VF190 Opt. Air Over Hydraulic.....	375756	14				47	
	Various Models 160 - 170 - 180 - 185 Series Opt. Air Over Hydraulic.....	375757	16				47	
	Various Models Air Over Hydraulic.....	375844	15				47	
	Various Models 160 - 170 - 180 - 185 Series.....	375680	17				41	
	Various Models 190 - 200 - 1800 - 1850 - 2010 - 2050 Series.....	374230	52	CALL	FOR	AVAILABILITY		
	Various Models 170 - 180 - 190 - 1800 - 1850 Series.....	374229	47	CALL	FOR	AVAILABILITY		
	1963	1600 - 1700 - 1800 Series Loadstar, w/o Residual Check Valve.....	2502982	23				48
		1500 Series Motor Home.....	2502119	14				39
Various Models.....		2502703	25				44	
Various Models.....		2502982	24				33	
Various Models Air Over Hydraulic.....		375901	14				47	
Various Metro Models.....		378804	13				43	
CO 4000 (Clutch Assist).....		2500187	9				48	
RF190, VF190 Opt. Air Over Hydraulic.....		375756	14				47	
Various Models 160 - 170 - 180 - 185 Series Opt. Air Over Hydraulic.....		375757	16				47	
Various Models Air Over Hydraulic.....		375844	15				47	
Various Models 160 - 170 - 180 - 185 Series.....		375680	17				41	
Various Models 190 - 200 - 1800 - 1850 - 2010 - 2050 Series.....		374230	52	CALL	FOR	AVAILABILITY		
Various Models 170 - 180 - 190 - 1800 - 1850 Series.....		374229	47	CALL	FOR	AVAILABILITY		
1962		1500 Series Motor Home.....	2502119	14				39
	Various Models.....	2502703	25				44	
	Various Models.....	2502982	24				33	
	Various Models Air Over Hydraulic.....	375901	14				47	
	Various Metro Models.....	378804	13				43	
	CO 4000 (Clutch Assist).....	2500187	9				48	
	RF190, VF190 Opt. Air Over Hydraulic.....	375756	14				47	
	Various Models 160 - 170 - 180 - 185 Series Opt. Air Over Hydraulic.....	375757	16				47	
	Various Models Air Over Hydraulic.....	375844	15				47	
	Various Models 160 - 170 - 180 - 185 Series.....	375680	17				41	
	Various Models 190 - 200 - 1800 - 1850 - 2010 - 2050 Series.....	374230	52	CALL	FOR	AVAILABILITY		
	Various Models 130 - 140 - 150 - 160 - 161 - 162 Series.....	374000	13				27	
	Various Models Field Inst. Air Over Hydraulic.....	N4105D	19				49	

**M  
E  
D  
I  
U  
M  
D  
U  
T  
Y  
A  
P  
P  
L  
I  
C  
A  
T  
I  
O  
N  
S**

# MEDIUM DUTY TRUCK APPLICATIONS



MEDIUM DUTY APPLICATIONS

YEAR	IHC/NAVISTAR TRUCK CONT'D VEHICLE - MODEL	HYD VAC or P.S. & M.C.	Wt. Lbs	POWER SEC. w/o M.C.	Wt. Lbs	PEDAL ROD CODE	PICT. NO.
1962	Various Models 170 - 180 - 190 - 1800 - 1850 Series.....	374229	47	CALL	FOR	AVAILABILITY	
1961-60	Various Metro Models.....	378804	13				43
	CO 4000 (Clutch Assist).....	2500187	9				48
	RF190, VF190 Opt. Air Over Hydraulic.....	375756	14				47
	Various Models 160 - 170 - 180 - 185 Series Opt. Air Over Hydraulic.....	375757	16				47
	Various Models Air Over Hydraulic.....	375844	15				47
	Various Models 160 - 170 - 180 - 185 Series.....	375680	17				41
	Various Models 190 - 200 - 1800 - 1850 - 2010 - 2050 Series.....	374230	52	CALL	FOR	AVAILABILITY	
	Various Models 130 - 140 - 150 - 160 - 161 - 162 Series.....	374000	13				27
	Various Models Field Inst. Air Over Hydraulic.....	N4105D	19				49
	Various Models 170 - 180 - 190 - 1800 - 1850 Series.....	374229	47	CALL	FOR	AVAILABILITY	
1959-56	RF190, VF190 Opt. Air Over Hydraulic.....	375756	14				47
	Various Models 160 - 170 - 180 - 185 Series Opt. Air Over Hydraulic.....	375757	16				47
	CO - S 180.....	374980	22				45
	Various Models Air Over Hydraulic.....	375844	15				47
	Various Models 160 - 170 - 180 - 185 Series.....	375680	17				41
	Various Models 190 - 200 - 1800 - 1850 - 2010 - 2050 Series.....	374230	52	CALL	FOR	AVAILABILITY	
	Various Models 160 - 170 - 180 - 185 Series.....	374980	22				45
	Various Models 130 - 140 - 150 - 160 - 161 - 162 Series.....	374000	13				27
	Various Models 170 - 190 - 200 Series.....	374750	25				46
	Various Models Field Inst. Air Over Hydraulic.....	N4105D	19				49
Various Models 170 - 180 - 190 - 1800 - 1850 Series.....	374229	47	CALL	FOR	AVAILABILITY		
1955-51	Various Models Air Over Hydraulic.....	375844	15				47
	Various Models 160 - 170 - 180 - 185 Series.....	375680	17				41
	Various Models 190 - 200 - 1800 - 1850 - 2010 - 2050 Series.....	374230	52	CALL	FOR	AVAILABILITY	
	Various Models 160 - 170 - 180 - 185 Series.....	374980	22				45
	Various Models 130 - 140 - 150 - 160 - 161 - 162 Series.....	374000	13				27
	Various Models 170 - 190 - 200 Series.....	374750	25				46
	Various Models Field Inst. Air Over Hydraulic.....	N4105D	19				49
	Various Models 170 - 180 - 190 - 1800 - 1850 Series.....	374229	47	CALL	FOR	AVAILABILITY	
1950	Various Models 160 - 170 - 180 - 185 Series.....	375680	17				41
	Various Models 190 - 200 - 1800 - 1850 - 2010 - 2050 Series.....	374230	52	CALL	FOR	AVAILABILITY	
	Various Models 160 - 170 - 180 - 185 Series.....	374980	22				45
	Various Models 190 - 200 - 1800 - 1850 - 2010 - 2050 Series.....	374230	52	CALL	FOR	AVAILABILITY	

YEAR	IHC/NAVISTAR TRUCK CONT'D VEHICLE - MODEL	HYD VAC or P.S. & M.C.	Wt. Lbs	POWER SEC. w/o M.C.	Wt. Lbs	PEDAL ROD CODE	PICT. NO.
1950	Various Models 130 - 140 - 150 - 160 - 161 - 162 Series.....	374000	13				27
	Various Models 170 - 190 - 200 Series.....	374750	25				46
	Various Models Field Inst. Air Over Hydraulic.....	N4105D	19				49
	Various Models 170 - 180 - 190 - 1800 - 1850 Series.....	374229	47	CALL	FOR	AVAILABILITY	
1949	Various Models 190 - 200 - 1800 - 1850 - 2010 - 2050 Series.....	374230	52	CALL	FOR	AVAILABILITY	
	Various Models 130 - 140 - 150 - 160 - 161 - 162 Series.....	374000	13				27
	Various Models 170 - 190 - 200 Series.....	374750	25				46
	Various Models Field Inst. Air Over Hydraulic.....	N4105D	19				49
	Various Models 170 - 180 - 190 - 1800 - 1850 Series.....	374229	47	CALL	FOR	AVAILABILITY	
1948-47	Various Models Field Inst. Air Over Hydraulic.....	N4105D	19				49
	Various Models 170 - 180 - 190 - 1800 - 1850 Series.....	374229	47	CALL	FOR	AVAILABILITY	
	Various Models K - KB - KBS - 5 - 7 Series.....	373853	22				45
1946-45	Various Models 170 - 180 - 190 - 1800 - 1850 Series.....	374229	47	CALL	FOR	AVAILABILITY	
	Various Models K - KB - KBS - 5 - 7 Series.....	373853	22				45
<b>MACK TRUCK</b>							
<b>VARIOUS MODELS</b>							
1966-65	A40, B34B, CBK, CBL, EF, EH.....	374300	44	CALL	FOR	AVAILABILITY	
	B421S, D421S.....	374230	52	CALL	FOR	AVAILABILITY	
1964-63	B30P, B30T, B30X, B34B.....	374750	25				46
	B421S, D421S.....	374230	52	CALL	FOR	AVAILABILITY	
	A40, B34B, CBK, CBL, EF, EH.....	374300	44	CALL	FOR	AVAILABILITY	
1962	B421S, D421S.....	374230	52	CALL	FOR	AVAILABILITY	
	B30P, B30T, B30X, B34B.....	374750	25				46
	A40, B34B, CBK, CBL, EF, EH.....	374300	44	CALL	FOR	AVAILABILITY	
	Various Models (Clutch Assist).....	2500506	9				48
1961	B421S, D421S.....	374230	52	CALL	FOR	AVAILABILITY	
	Various Models (Air/Over Hydraulic).....	376504	14				47
	B30P, B30T, B30X, B34B.....	374750	25				46
	A40, B34B, CBK, CBL, EF, EH.....	374300	44	CALL	FOR	AVAILABILITY	
	Various Models (Clutch Assist).....	2500506	9				48
1960	Various Models (Air/Over Hydraulic).....	376504	14				47
	B421S, D421S.....	374230	52	CALL	FOR	AVAILABILITY	
	B30P, B30T, B30X, B34B.....	374750	25				46
	A40, B34B, CBK, CBL, EF, EH.....	374300	44	CALL	FOR	AVAILABILITY	
	Various Models (Clutch Assist).....	2500506	9				48
1959	Various Models (Air/Over Hydraulic).....	376504	14				47
	B421S, D421S.....	374230	52	CALL	FOR	AVAILABILITY	
	B30P, B30T, B30X, B34B.....	374750	25				46
	A40, B34B, CBK, CBL, EF, EH.....	374300	44	CALL	FOR	AVAILABILITY	
	EE, EF.....	374980	22				45
	A20-20V-30, B20P, B30-E-X, D20P.....	375680	17				41
1958	Various Models (Air/Over Hydraulic).....	376504	14				47
	B421S, D421S.....	374230	52	CALL	FOR	AVAILABILITY	

**M  
E  
D  
I  
U  
M  
D  
U  
T  
Y  
A  
P  
P  
L  
I  
C  
A  
T  
I  
O  
N  
S**

# MEDIUM DUTY TRUCK APPLICATIONS



MEDIUM DUTY APPLICATIONS

YEAR	MACK TRUCK CONT'D VEHICLE - MODEL	HYD VAC or P.S. & M.C.	Wt. Lbs	POWER SEC. w/o M.C.	Wt. Lbs	PEDAL ROD CODE	PICT. NO.
1958	B30P, B30T, B30X, B34B.....	374750	25				46
	Various Models (Air/Over Hydraulic).....	375756	14				47
	A20-20V-30, B20P, B30-E-X, D20P.....	375680	17				41
	A40, B34B, CBK, CBL, EF, EH.....	374300	44	CALL	FOR	AVAILABILITY	
	EE, EF.....	374980	22				45
1957	B421S, D421S.....	374230	52	CALL	FOR	AVAILABILITY	
	B30P, B30T, B30X, B34B.....	374750	25				46
	A20-20V-30, B20P, B30-E-X, D20P.....	375680	17				41
	A40, B34B, CBK, CBL, EF, EH.....	374300	44	CALL	FOR	AVAILABILITY	
	EE, EF.....	374980	22				45
1956	A20-20V-30, B20P, B30-E-X, D20P.....	375680	17				41
	A40, B34B, CBK, CBL, EF, EH.....	374300	44	CALL	FOR	AVAILABILITY	
	EE, EF.....	374980	22				45
1955-50	A20-20V-30, B20P, B30-E-X, D20P.....	375680	17				41
	And 57-64 EM, EQ B30S, D30P, D42P.....	374229	47	CALL	FOR	AVAILABILITY	
	A40, B34B, CBK, CBL, EF, EH.....	374300	44	CALL	FOR	AVAILABILITY	
	EE, EF.....	374980	22				45
1949-46	And 57-64 EM, EQ B30S, D30P, D42P.....	374229	47	CALL	FOR	AVAILABILITY	
	A40, B34B, CBK, CBL, EF, EH.....	374300	44	CALL	FOR	AVAILABILITY	
	EE, EF.....	374980	22				45
1945	EE, EF.....	374980	22				45

## UTILITY TRAILERS

### ULTRAVAL UNITS

1977-73	25,000 to 30,000 GVW.....	C4702B	39				31
	Various Types.....	C4021	15				26
	Various Types w/ Reservoir.....	C4007F	17				26
	Various Types w/o Reservoir.....	C4007	17				20
	Various Types.....	C479B	22				26
	Various Types.....	C472A	17				26
1972-61	Various Types.....	C4021	15				26
	Various Types w/ Reservoir.....	C4007F	17				26
	Various Types w/o Reservoir.....	C4007	17				20
	Various Types.....	C479B	22				26
	Various Types.....	C472A	17				26
ALL	Various Types w/ Bendix Hydrovac.....	2700383	24				37
	Various Types w/ Bendix Hydrovac.....	2700384	24				37
	Various Types w/ Bendix Hydrovac.....	2700385	24				37

## WHITE TRUCKS

### VARIOUS MODELS

1967	Various Models (Clutch Assist.).....	2500506	9				48
1966-63	Various Models (Clutch Assist.).....	2500506	9				48
	3014 Model.....	374000	13				27
	Various 20 - 22 - 3000T - 3022 - PLT Models.....	374300	44	CALL	FOR	AVAILABILITY	
1962	Various Models Air/Over Hydraulic.....	375844	15				47
	Various Models Bendix Hydrovac.....	376155	18				41
	Various Models (Clutch Assist.).....	2500506	9				48
	3014 Model.....	374000	13				27
1962	Various 20 - 22 - 3000T - 3022 - PLT Models.....	374300	44	CALL	FOR	AVAILABILITY	
1961-60	Various Models (Clutch Assist.).....	2500506	9				48
	3014 Model.....	374000	13				27
	Various 20 - 22 - 3000T - 3022 - PLT Models.....	374300	44	CALL	FOR	AVAILABILITY	
1959-50	Various Models Air/Over Hydraulic.....	375440	15				47
	3014 Model.....	374000	13				27
	Various 16 - 18 - 20 - 22 - 3022 - 3026 - 9000T Models	374750	25				46

YEAR	WHITE TRUCKS CONT'D VEHICLE - MODEL	HYD VAC or P.S. & M.C.	Wt. Lbs	POWER SEC. w/o M.C.	Wt. Lbs	PEDAL ROD CODE	PICT. NO.
1959-50	Various 14 - 16 - 18 - 3014 - 3015 - 3016 - 3018 Models	374980	22				45
	Various 20 - 22 - 3000T - 3022 - PLT Models.....	374300	44	CALL	FOR	AVAILABILITY	
	Various 20 - 22 - 26 - 3020 - 3022 - Models 28,500 GVW	374230	52	CALL	FOR	AVAILABILITY	
1949	3014 Model.....	374000	13				27
	Various 16 - 18 - 20 - 22 - 3022 - 3026 - 9000T Models	374750	25				46
	Various 14 - 16 - 18 - 3014 - 3015 - 3016 - 3018 Models	374980	22				45
	Various 20 - 22 - 3000T - 3022 - PLT Models	374300	44	CALL	FOR	AVAILABILITY	
	Various 20 - 22 - 26 - 3020 - 3022 - Models 28,500 GVW	374230	52	CALL	FOR	AVAILABILITY	
1948-46	Various 20 - 22 - 3000T - 3022 - PLT Models	374300	44	CALL	FOR	AVAILABILITY	
	Various 20 - 22 - 26 - 3020 - 3022 - Models 28,500 GVW	374230	52	CALL	FOR	AVAILABILITY	
	WB14..... NOTE: Most White Trucks Are Equiped With Air Brake Systems. See Air Catalog.	373853	22				45

**M  
E  
D  
I  
U  
M  
D  
U  
T  
Y  
A  
P  
P  
L  
I  
C  
A  
T  
I  
O  
N  
S**

**BENDIX MASTER VAC - TANDEM DIAPHRAGM  
8 3/4" DIAMETER (WITH OR W/O MAST. CYL.)**  
PIC #1

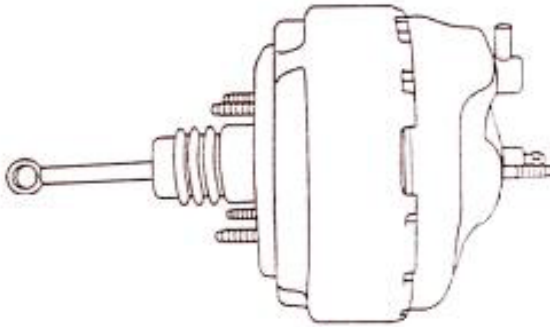

**CORE TYPE 44**

TYPICAL DRAWING - PUSH ROD, MOUNTING STUDS, AND/OR MOUNTING BRACKET MAY BE DIFFERENT IN APPEARANCE

**BENDIX MASTER VAC - SINGLE DIAPHRAGM  
9" DIAMETER (WITH OR W/O MAST. CYL.)**  
PIC #2

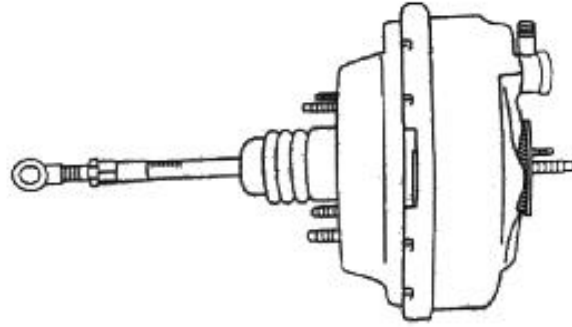

**CORE TYPE 40**

TYPICAL DRAWING - PUSH ROD, MOUNTING STUDS, AND/OR MOUNTING BRACKET MAY BE DIFFERENT IN APPEARANCE

**BENDIX MASTER VAC - TANDEM DIAPHRAGM  
9 1/4" DIAMETER (WITH OR W/O MAST. CYL.)**  
PIC #3

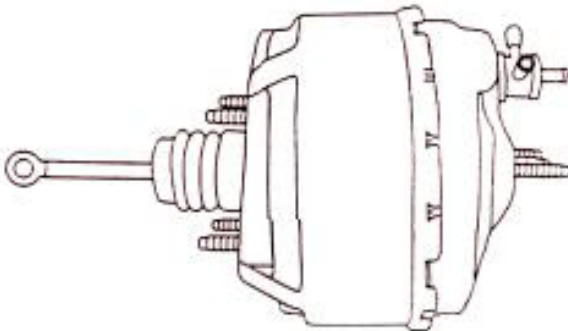

**CORE TYPE 54**

TYPICAL DRAWING - PUSH ROD, MOUNTING STUDS, AND/OR MOUNTING BRACKET MAY BE DIFFERENT IN APPEARANCE

**BENDIX MASTER VAC - SINGLE DIAPHRAGM  
TAPERED MOUNTING CAN  
10 3/4" DIAMETER (WITH OR W/O MAST. CYL.)**  
PIC #4

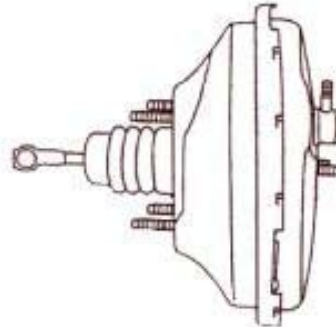

**CORE TYPE 47**

TYPICAL DRAWING - PUSH ROD, MOUNTING STUDS, AND/OR MOUNTING BRACKET MAY BE DIFFERENT IN APPEARANCE

**BENDIX MASTER VAC - SINGLE DIAPHRAGM - FLAT MOUNTING CAN  
11 1/4" DIAMETER (WITH OR W/O MAST. CYL.)**  
PIC #5

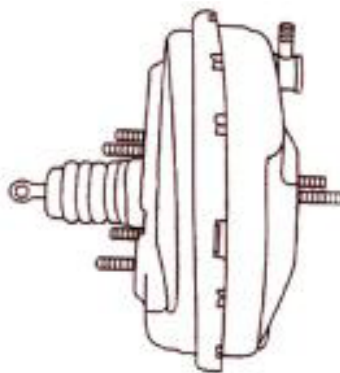

**CORE TYPE 48**

TYPICAL DRAWING - PUSH ROD, MOUNTING STUDS, AND/OR MOUNTING BRACKET MAY BE DIFFERENT IN APPEARANCE

**M  
E  
D  
I  
U  
M  
D  
U  
T  
Y**

**MIDLAND MASTER VAC (MEDIUM DUTY TRUCK) - BAND TYPE (WITH METAL HUB)**  
**9 1/2" OR 11 1/2" DIAMETER - (WITH OR W/O MAST. CYL.)**  
PIC #6

Part Number	Master Cyl. Type	Part No. W/O Cyl.	Diameter	Push Rod Length*	To
C4025E	Single	C4026B3	9 1/2"	7 1/8"	C/L Eye
C4025F	Single	C4026B6	9 1/2"	10 1/4"	C/L Eye
C4029	Single	C4028A	11 1/2"	10 1/4"	C/L Eye

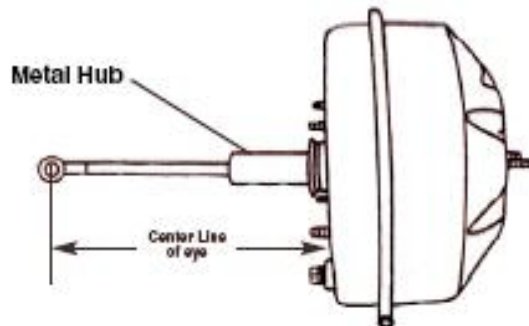

**CORE TYPE 20**

\* THE PEDAL ROD LENGTHS ARE MEASURED FROM THE CAN TO THE CENTER OF THE EYE ON THE PUSH ROD.

NOTE: FURNISHED LESS MOUNTING BRACKET.  
NOTE: WE FURNISH THE SINGLE VACUUM TUBE. IF THE DOUBLE TUBE IS USED IT CAN BE CHANGED FROM THE OLD UNIT.

**MIDLAND MASTER VAC (MEDIUM DUTY TRUCK) - BAND TYPE (WITH BLACK PLASTIC HUB)**  
**11 11/16" DIAMETER - (WITH OR W/O MAST. CYL.)**  
PIC #7

Part Number	Master Cyl. Type	Part No. W/O Cyl.	Length of Studs	Push Rod Length*	To
C4063	Single	C4044D	1"	5 3/4"	C/L Eye
C4072D	Dual	C4044KD	1 3/8"	14 1/4"	C/L Eye
C4073A	Dual	C4044KA	1 3/8"	7 3/4"	C/L Eye
C4074	Single	C4037L	2"	6 3/4"	End Thrds
C4074A	Single	C4037NA	1 1/8"	8"	End Thrds
C4074C	Single	C4037NC	1 1/8"	13"	End Thrds

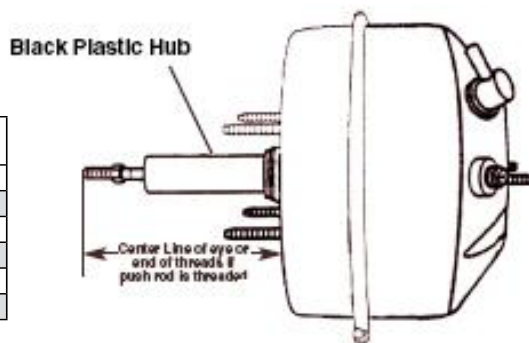

**CORE TYPE 19**

\* THE PEDAL ROD LENGTHS ARE MEASURED FROM THE CAN TO THE CENTER OF THE EYE OR TO THE END OF THE PUSH ROD.

NOTE: THESE UNITS ARE BOXED WITH THE PUSH ROD BUT NOT INSTALLED TO PREVENT DAMAGE TO THE PLASTIC HUB.  
NOTE: ON THREADED PUSH RODS WE DO NOT FURNISH THE CLEVIS.

**MIDLAND MASTER VAC (MEDIUM DUTY TRUCK) - BAND TYPE (WITH BLACK PLASTIC HUB)**  
**13" DIAMETER - (WITH OR W/O MAST. CYL.)**  
PIC #8

Part Number	Master Cyl. Type	Part No. W/O Cyl.	Length of Studs	Push Rod Length*	To
C4083	Dual	C4084JJ	5/8"	13 1/2"	C/L Eye
C4083F	Dual	C4084JW	7/8"	11"	C/L Eye
C4085G	Dual	C4084E	2 3/8"	6 3/4"	C/L Eye
C4085H	Single	C4084E	2 3/8"	6 3/4"	C/L Eye
C4085M	Dual	C4084H	2 3/8"	10 3/8"	C/L Eye
C4085P	Single	C4084H	2 3/8"	10 3/8"	C/L Eye
C4089	Dual	C4084B	5/8"	7 1/4"	End Thrds
C4089A	Dual	C4084BM	5/8"	13 1/2"	End Thrds
C4089B	Dual	C4084C	5/8"	11"	End Thrds
C4089G	Dual	C4084BJ	5/8"	8 1/4"	End Thrds

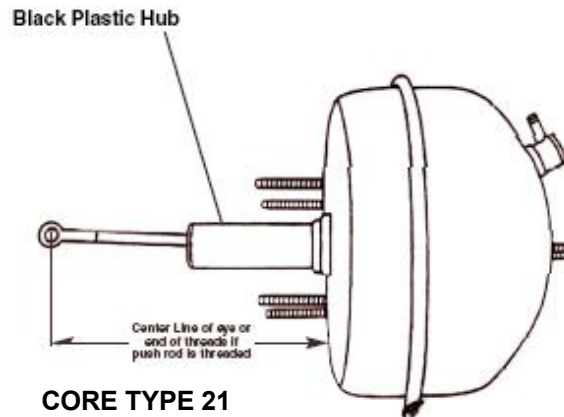

**CORE TYPE 21**

\* THE PEDAL ROD LENGTHS ARE MEASURED FROM THE CAN TO THE CENTER OF THE EYE OR TO THE END OF THE PUSH ROD.

NOTE: THESE UNITS ARE BOXED WITH THE PUSH ROD BUT NOT INSTALLED TO PREVENT DAMAGE TO THE PLASTIC HUB.  
NOTE: ON THREADED PUSH RODS WE DO NOT FURNISH THE CLEVIS.

**MEDIUM DUTY**

# Prior AUTOMOTIVE PRODUCTS, LLC

## TYPICAL DRAWINGS, PICTURES, AND IDENTIFICATION DATA

**Pict. 9**

Bendix Hydro Max  
 (With or W/O Mast. Cyl.)  
 Furnished Less Electric Motor  
 Electric Motor Available, See Picture  
 No. 47 Below.

Flow Switch Furnished

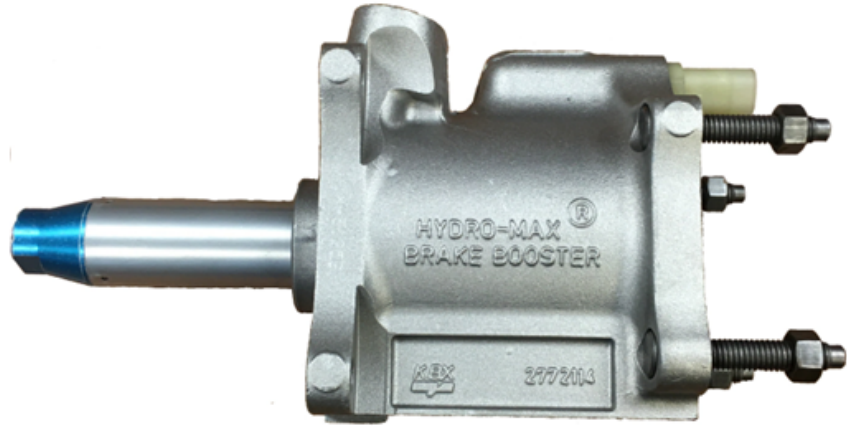

**Note:** Customer Must Use Their Own Pedal Rod  
 Instructions for Pedal Rod Replacement  
 Included with each Unit

Casting #	Prior #
2771371	3700273
2771424	3700394
2772114	3700625

Core Type 33

**Pict. 10**

Electric Motor For Hydro Max

Part No. 2771320  
 w/ stud



Part No. 2771420  
 w/ wire & pigtail  
**Single Wire**



Part No. 2772729  
 w/ wire & pigtail  
**Double Wire**

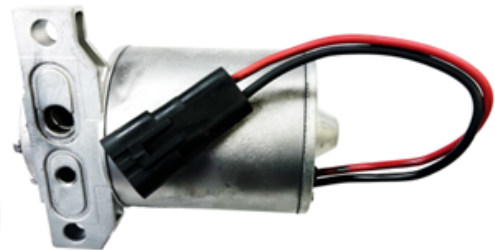

M  
E  
D  
I  
U  
M  
  
D  
U  
T  
Y

Pict. 11

MASTER CYLINDER FOR BENDIX HYDRO MAX

RESERVOIR  
A



RESERVOIR  
B

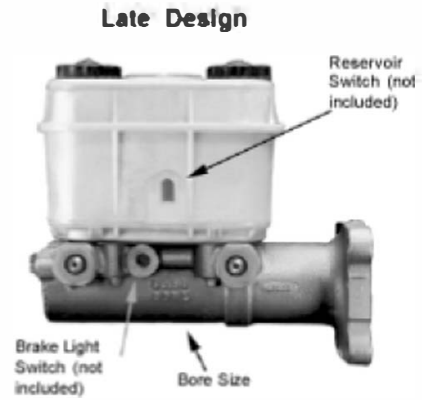

Part Number	Bore Decimal	Bore Millimeter	Reservoir Type	Primary Outlet	Secondary Outlet	Brake Light Switch	Reservoir Switch	Application Info	Notes
1992R	1.75	44.45	A	9/16 X 18	1/2 X 20	N	N	GM	
1994R	2.00	50.80	A	9/16 X 18	1/2 X 20	N	N	GM	
1995R	2.00	50.80	A	9/16 X 18	1/2 X 20	N	N	Ford, Bosch AM	
1999R	1.75	44.45	A	9/16 X 18	1/2 X 20	N	N	Ford, Bosch AM	No flares in brake line ports
2339R	2.00	50.80	B	9/16 X 18	1/2 X 20	Y	N	Navistar, Ford	
2379R	2.00	50.80	B	9/16 X 18	1/2 X 20	Y	N	Navistar, Ford, Thomas Built	
2632R	1.75	44.45	B	9/16 X 18	1/2 X 20	Y	N	Ford	
2234R	2.00	50.80		9/16 X 18	1/2 X 20	Y	Y		

MEDIUM DUTY

## TYPICAL DRAWINGS, PICTURES, AND IDENTIFICATION DATA

**Pict. 12**

Delco Dual Power  
(Vacuum And Hydraulic  
Ordered Separately)  
See Pict. 45 For Mast. Cyl.

Hydraulic Booster

Internal  
Push Rod

Core Type 30

Rod Length

Vacuum Booster

Core Type 73

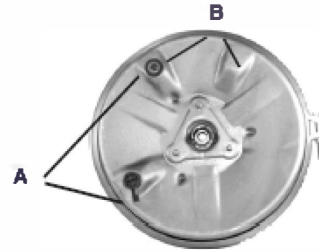

Prior Number	GM Number	IHC Number	Casting Number
7700435	18001047	504837C91	2623501

Prior Number	GM Number	IHC Number	Vac Ports Location	Push Rod Length
7700436	18001072		A	7"
7700437	18003144	488643C91	B	5 1/4"

**Note:** Customer Must Use Their Own Internal Push Rod - Between Hydraulic Booster And Mast. Cyl.

**Pict. 13**

Delco Hy Power  
Furnished Less Master Cylinder  
Furnished Less Electric Motor  
Furnished Less Flow Switch

Internal Push Rod

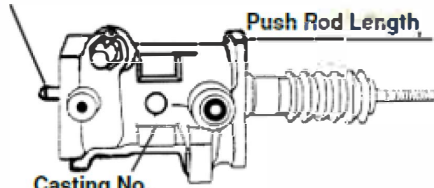

Casting No.

Core Type 31

**Pict. 14**

Electric Motor  
Part No. 6700974  
w/ Wire & Pigtail

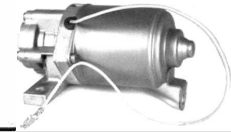

Electric Motor  
Part No. 6700975  
w/ Female Plug

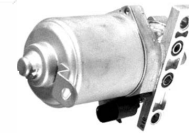

Prior Number	Casting Number	GM Number	Input
7700438	2623435	18003998	Flare
7700439	2623435	18001810	Flare
	18015765	18014080	Flare
	5474216		Flare
7700556	18015765	18001810	Tube-O

Push Rod Length	Push Rod Type
5 1/2"	Threaded
7"	Threaded
7"	Threaded
7"	Threaded
9"	Solid Eye

**Note:** Customer Must Use Their Own Internal Push Rod.

**Note:** See Pict. 45 For Mast. Cyl.

**Pict. 15**

Master Cylinders For Delco Dual  
Power And Delco Hy Power

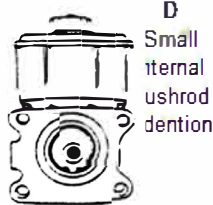

**D**  
Small  
Internal  
Pushrod  
Indention

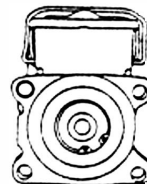

**E**  
Large  
Internal  
Pushrod  
Indention



**F**  
Flat  
Internal  
Pushrod  
Indention

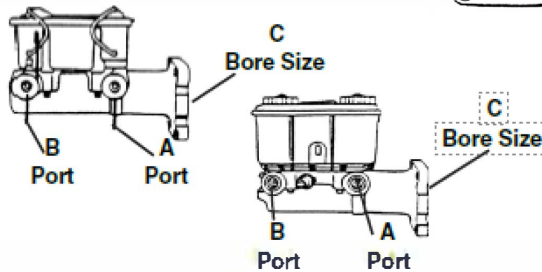

Cylinder Part No	A	B	C	D	E	F
6711348	9/16 - 18	1/2 - 20	1 3/4"		X	
6711885	9/16 - 18	1/2 - 20	2"			X
6711898	3/4 - 18	11/16 - 18	2"		X	
6711908	3/4 - 18	11/16 - 18	2"	X		
6711910	3/4 - 18	11/16 - 18	1 3/4"	X		
6711994	9/16 - 18	1/2 - 20	2"	X		

**Note:** Either plastic or metal reservoir will work for each other.

**MIDLAND HY POWER  
8" DIAMETER  
PIC #16**

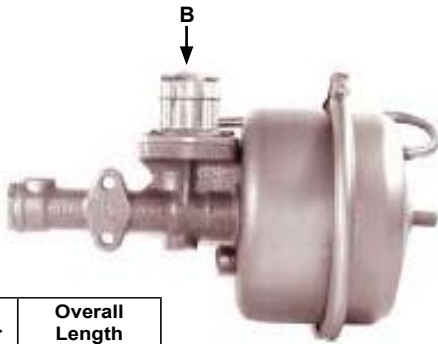

Part Number	Overall Length
C468	13 7/8"
C490	10 13/16"
C490G	10 13/16"

**CORE TYPE 85**

NOTE: C490G HAS ATMOSPHERIC TUBE INSTEAD OF PERFORATED BREATHER (SEE B).

**MIDLAND HY POWER  
10" DIAMETER  
PIC #17**

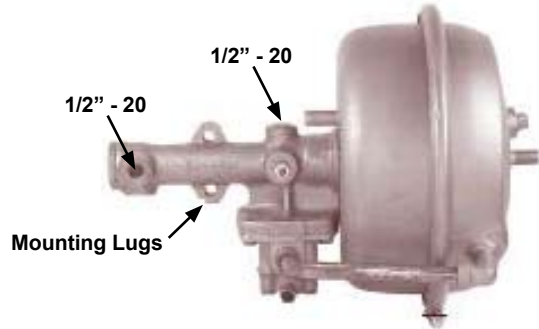

Part Number	Overall Length
C462	13 7/8"

**CORE TYPE 85**

HAS TWO MOUNTING LUGS OPPOSITE EACH OTHER, HAS SQUARE CONTROL VALVE HOUSING.

**MIDLAND HY POWER  
10" DIAMETER  
PIC #18**

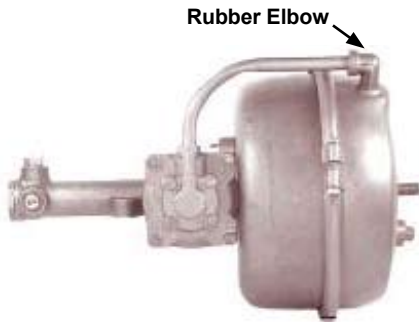

Part Number	Overall Length
C4003	13 3/8"

**CORE TYPE 85**

SIMILAR TO C462, HAS LARGER CONTROL VALVE HOUSING AND HAS RUBBER ELBOW ON VACUUM CHAMBER

**MIDLAND HY POWER  
10" DIAMETER  
PIC #19**



Part Number	Overall Length
C447	12"

**CORE TYPE 85**

THIS IS THE ONLY HY POWER UNIT WHERE A RUBBER HOSE IS USED AS AN ATMOSPHERIC LINE.

**MIDLAND HY POWER  
10" DIAMETER  
PIC #20**

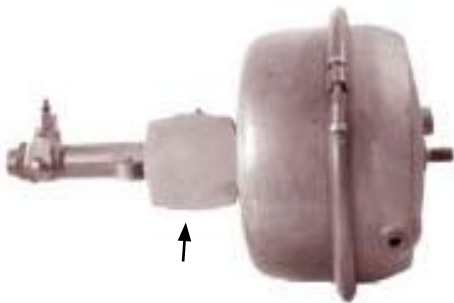

Part Number	Overall Length
C4007	15 7/8"

**CORE TYPE 85**

SLAVE UNIT ONLY. MUST BE USED WITH C4013. NO CONTROL VALVE (SEE ARROW).

**MIDLAND HY POWER  
11 1/2" DIAMETER  
PIC #21**

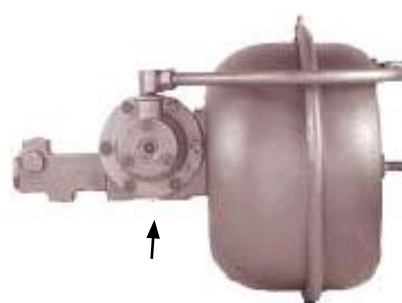

Part Number	Overall Length
C449	15 1/4"

**CORE TYPE 85**

HAS TWO OFFSET MOUNTING HOLES, HAS ROUND CONTROL VALVE HOUSING (SEE ARROW).

**MIDLAND HY POWER  
11 1/2" DIAMETER  
PIC #22**

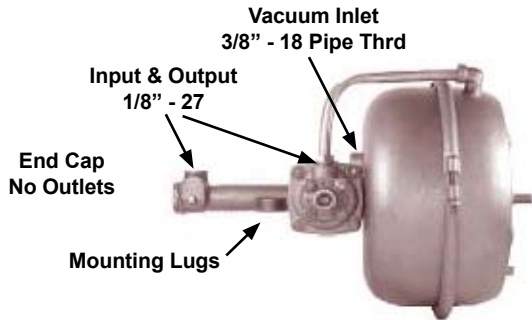

Part Number	Overall Length
C464	16 1/8"

**CORE TYPE 85**

HAS TWO MOUNTING LUGS OPPOSITE EACH OTHER (SEE ARROW).

**MIDLAND HY POWER  
11 1/4" DIAMETER  
PIC #23**

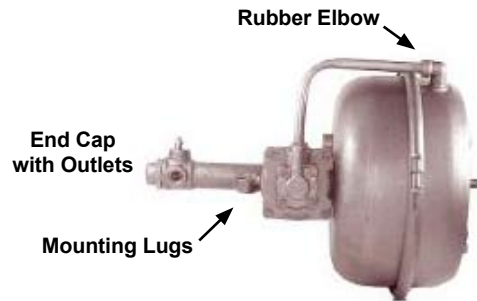

Part Number	Overall Length
C4012	16 3/4"

**CORE TYPE 85**

HAS TWO MOUNTING LUGS OPPOSITE EACH OTHER (SEE ARROW).

**MIDLAND HY POWER  
11 11/16" DIAMETER  
PIC #24**



Part Number	Overall Length
C4034A	16 1/2"
C4035A	19"

**CORE TYPE 85**

**MIDLAND HY POWER  
13" DIAMETER  
PIC #25**



Part Number	Overall Length
C4090	19 3/8"

**CORE TYPE 85**

**MIDLAND TRAILER HY POWER  
PIC #26**

Furnished Less Reservoir



Part Number	Vac. Cyl. Diameter	Overall Length
C472A	10"	14 3/4"
C479B	11 1/2"	17"
C4007F	10"	15 7/8"
C4021	8"	15 3/4"

**CORE TYPE 85**

**MIDLAND SUBSTITUTE  
FOR PART NO. 374000  
FOR ORIGINAL UNIT SEE 374000F - PICTURE NO. 43  
PIC #27**



**CORE TYPE 95**

DUE TO THE ORIGINAL CORE AVAILABILITY THIS MIDLAND UNIT MAY BE SUBSTITUTED FOR THE 374000. THIS UNIT WILL NOT WORK ON FORKLIFT APPLICATIONS.

**MIDLAND HY POWER TANDEM DIAPHRAGM**  
**11 1/4" DIAMETER**  
PIC #28



Part Number	Overall Length
C4013	23 3/4"

**CORE TYPE 88**

NOTE: HAS RUBBER ELBOW ON VACUUM CHAMBER (SEE ARROW).

**MIDLAND HY POWER TANDEM DIAPHRAGM**  
**11 11/16" DIAMETER**  
PIC #29



Part Number	Overall Length
C4036A	25 1/4"
C4042B	23 1/4"

**CORE TYPE 88**

**MIDLAND HY POWER TANDEM DIAPHRAGM**  
**11 11/16" DIAMETER**  
PIC #30



Part Number	Overall Length
C4057	26 1/4"
C4058	22 7/16"

**CORE TYPE 88**

**MIDLAND TRAILER HY POWER**  
**11 3/4" DIAMETER**  
PIC #31



Part Number	Overall Length
C4702B	25 1/2"

**CORE TYPE 88**

NO FLUID RESERVOIR OR CONTROL VALVE (SEE A).

**MIDLAND HY POWER TANDEM DIAPHRAGM**  
**11 1/2" DIAMETER - 23 1/4" OVERALL LENGTH**  
PIC #32

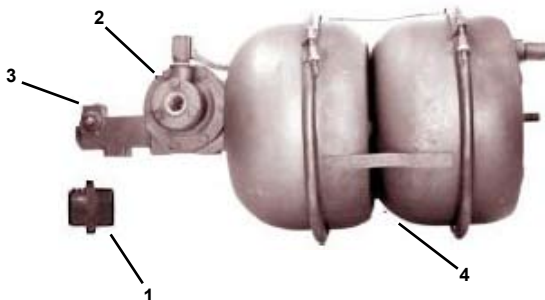

**CORE TYPE 88**

C448, C448G, C448R, C448R WILL INTERCHANGE - EARLY MODEL HAS SHIELD BETWEEN THE TWO CANS & 1/8-27 NPT OUTPUT PORT ON SIDE OF SLAVE CYLINDER.

C448K HAS RESIDUAL CHECK VALVE IN THE SLAVE CYLINDER END NUT. IT HAS 1/2-20 OUTPUT PORT IN THE END CAP (SEE ARROW 1).

\* LATE MODEL HAS NO SHIELD (SEE ARROW 4).

\*\* C448G & C448K ARE THE SAME IN APPEARANCE EXCEPT FOR THE DIFFERENT SLAVE CYLINDER NUTS AND DIFFERENT POSITIONED OUTPUT PORTS.

NOTE: C448M HAS ONE BLEEDER SCREW AT CONTROL VALVE HOUSING (SEE ARROW 2). ALSO HAS A PIPE PLUG IN THE END OF THE SLAVE CYLINDER (SEE ARROW 3).

NOTE: C448R HAS TWO BLEEDER SCREWS, ONE AT ARROW 2 AND ONE AT ARROW 3, INSTEAD OF PIPE PLUG.

**BENDIX SINGLE DIAPHRAGM HYDROVAC WITHOUT BRACKET**

PIC #33

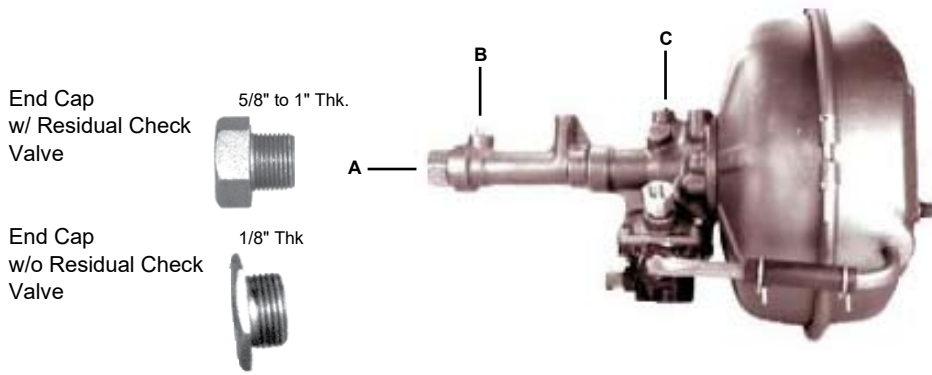

**CORE TYPE 90**

Part Number	Output Port Size	Output Location	Input (C) Port Size	Vacuum Inlet Size	Atmospheric Breather	Residual Check Valve	Vacuum Diameter	Overall Length
2501350	5/16" - I.F.	A	5/16" - I.F.	3/8" Pipe	3/4" Tube	Yes	12 3/4"	18"
2501370	5/16" - I.F.	B	5/16" - I.F.	3/8" Pipe	3/4" Tube	No	11"	14"
2501625	1/2"-20	B	1/2" - 20	1/2" Pipe	3/4" Tube	No	12 3/4"	17 1/2"
2502982	1/2" - 20	A	1/2" - 20	1/2" Pipe	3/4" Tube	No	12 3/4"	18"
2508819	7/16" - 20	A	1/4" - I.F.	1/2" Pipe	3/4" Tube	Yes	12 3/4"	18"
2510296	1/2" - 20	A	1/2" - 20	1/2" Pipe	3/4" Tube	Yes	12 3/4"	
2510555	5/16" - I.F.	A	1/4" - I.F.	1/2" - I.F.	1/2" Tube	No	11"	17 1/2"
2513492	5/16" - I.F.	A	5/16" - I.F.	1/2" Pipe	3/4" Tube	Yes	12 3/4"	18 11/16"
2513494	5/16" - I.F.	A	5/16" - I.F.	1/2" Pipe	3/4" Tube	No	12 3/4"	17 3/4"

NOTE: 2501625 HAS A GRAVITY FLOW FLUID LINE. THE LINE COMES FROM THE RESERVOIR OF THE MASTER CYLINDER DOWN TO THE HYDROVAC AT PORT A. OUTLET B WILL THEN GO TO WHEELS.

NOTE: THE RESIDUAL CHECK VALVE WILL BE LOCATED IN THE END CAP AT PORT A.

NOTE: I.F. = INVERTED FLAIR

**BENDIX SINGLE DIAPHRAGM HYDROVAC WITH BRACKET**

PIC #34

Note:

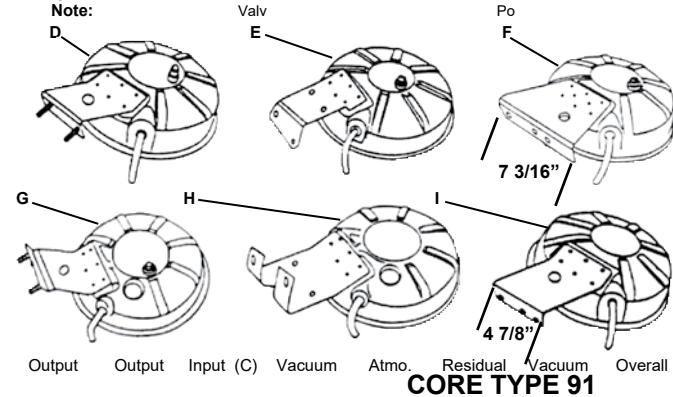
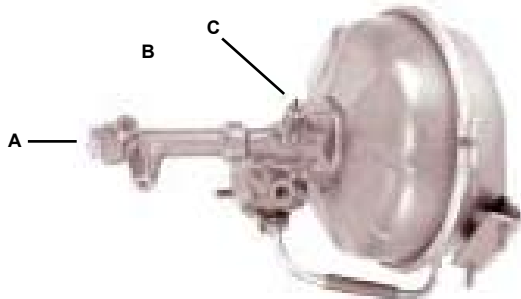

**CORE TYPE 91**

Part Number	Bracket Type	Output Port Size	Output Location	Input (C) Port Size	Vacuum Inlet Size	Atmospheric Breather	Residual Check Valve	Vacuum Diameter	Overall Length
2501847	G	5/16" - I.F.	B	1/4" - I.F.	1/2" - I.F.	1/2" Tube	No	11"	16"
2501850	D	5/16" - I.F.	B	1/4" - I.F.	1/2" - I.F.	1/2" Tube	Yes	12 3/4"	17 1/2"
2503139	D	5/16" - I.F.	A	5/16" - I.F.	1/2" - I.F.	1/2" Tube	Yes	12 3/4"	17 5/8"
2503151	G	5/16" - I.F.	A	1/4" - I.F.	1/2" - I.F.	1/2" Tube	No	11"	16"
2504188	D	5/16" - I.F.	A	1/4" - I.F.	1/2" - I.F.	1/2" Tube	No	12 3/4"	17"
2508059	D	7/16" - 20	A	1/4" - I.F.	1/2" Pipe	3/4" Tube	Yes	12 3/4"	19"
2509558	I	5/16" - I.F.	A	5/16" - I.F.	1/2" Pipe	3/4" Tube	Yes	12 3/4"	19"
2510027	E	1/4" - I.F.	A	1/4" - I.F.	1/2" - I.F.	1/2" Tube	Yes	12 3/4"	19"
2510065	F	1/4" - I.F.	A	1/4" - I.F.	1/2" Pipe	3/4" Tube	Yes	12 3/4"	19"
2510813	H	5/16" - I.F.	A	1/4" - I.F.	1/2" - I.F.	1/2" Tube	No	11"	18 1/2"

NOTE: 2501850 HAS A GRAVITY FLOW FLUID LINE. THE LINE COMES FROM THE RESERVOIR OF THE MASTER CYLINDER DOWN TO THE HYDROVAC AT PORT A. OUTLET B WILL THEN GO TO WHEELS.

NOTE: THE RESIDUAL CHECK VALVE WILL BE LOCATED IN THE END CAP AT PORT A.

NOTE: I.F. = INVERTED FLAIR

**MEDIUM DUTY**

**BENDIX TANDEM DIAPHRAGM HYDROVAC**

PIC #35

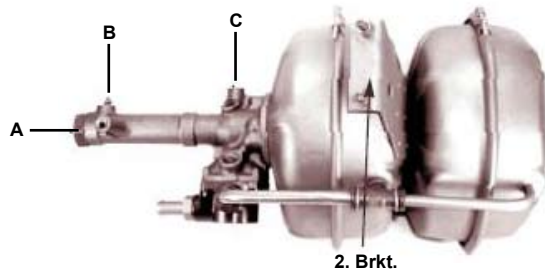

**CORE TYPE 92**

Part Number	Output Port Size	Output Location	Input (C) Port Size	Vacuum Inlet Size	Atmospheric Breather	Residual Check Valve	Vacuum Diameter	Overall Length
2501852	5/16" - I.F.	B	1/4" - I.F.	1/2" - I.F.	3/4" Tube	Yes	12 3/4"	24 1/2"
2503123	5/16" - I.F.	A	5/16" - I.F.	1/2" - I.F.	3/4" Tube	Yes	12 3/4"	24 5/8"
2506209	1/2" - 20	A	5/16" - I.F.	1/2" Pipe	1" Tube	No	12 3/4"	24 7/8"
2507224	1/2" - 20	A	5/16" - I.F.	1/2" Pipe	1/4" Tube	No	12 3/4"	24 5/8"
2508065	1/2" - 20	A	5/16" - I.F.	1/2" Pipe	1/4" Tube	Yes	12 3/4"	24 7/8"
2509605	1/4" - I.F.	A	5/16" - I.F.	1/2" Pipe	3/4" Tube	Yes	12 3/4"	24 5/8"
2513493	5/16" - I.F.	A	5/16" - I.F.	1/2" - I.F.	1" Tube	No	12 3/4"	26 1/8"

**NOTE: 2501852 HAS A GRAVITY FLOW FLUID LINE. THE LINE COMES FROM THE RESERVOIR OF THE MASTER CYLINDER DOWN TO THE HYDROVAC AT PORT A. OUTLET B WILL THEN GO TO WHEELS.**

**NOTE: 2506209 IS FOR 1967 I.H.C. TRUCK ONLY.**

**NOTE: 2507224 HAS BRACKET ON OPPOSITE SIDE OF CAN.**

**NOTE: 2508065 IS FOR 1968-80 I.H.C. TRUCK.**

**NOTE: I.F. = INVERTED FLAIR**

**M  
E  
D  
I  
U  
M  
D  
U  
T  
Y**

**BENDIX TRAILER HYDROVAC**

PIC #37

**CORE TYPE 94**

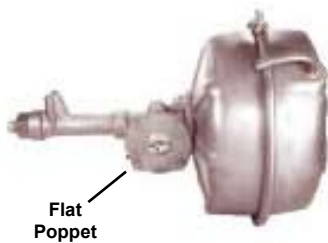

**PART NO. 2700383  
FLAT POPPET W/O BRKT.  
WITH PLUG**

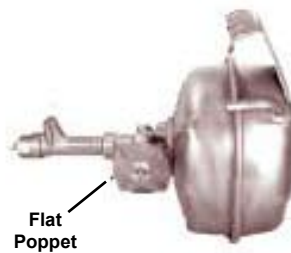

**PART NO. 2700384  
FLAT POPPET WITH BRKT.  
WITH PLUG**

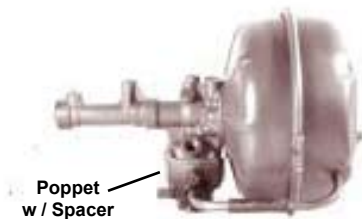

**PART NO. 2700385  
DOUBLE POPPET W/O  
BRKT. W/O PLUG**

**BENDIX HYDROVAC**  
**5 1/4" DIAMETER - 3" VACUUM UNIT DEPTH**  
PIC #38



Part Number	Overall Length
376500	10"
377011	10"

**CORE TYPE 95**

**BENDIX HYDROVAC**  
**11" DIAMETER**  
PIC #39



Part Number	Overall Length
2500660	13"
2502119	13"

**CORE TYPE 96**

NOTE: 2502119 HAS 2 LONGER MOUNTING BOLTS AT BOTTOM OF FACE PLATE (SEE A). ALSO DOES NOT HAVE MOUNTING BOLT (SEE B).

**BENDIX HYDROVAC**  
**11" DIAMETER**  
PIC #40



Part Number	Overall Length
2501424	13"

**CORE TYPE 96**

NOTE: SLAVE UNIT ONLY - USED WITH ANOTHER UNIT THAT HAS VACUUM CONTROL.

**BENDIX HYDROVAC**  
**12 5/8" DIAMETER**  
PIC #41

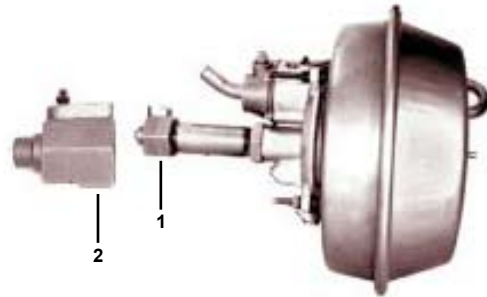

Part Number	Overall Length	End Cap Type	Notes
375680	16"	1	W/O Residual Check Valve
376155	16"	2	With Residual Check Valve

**CORE TYPE 96**

**BENDIX HYDROVAC**  
**6 3/4" DIAMETER (SEE A)**  
PIC #42

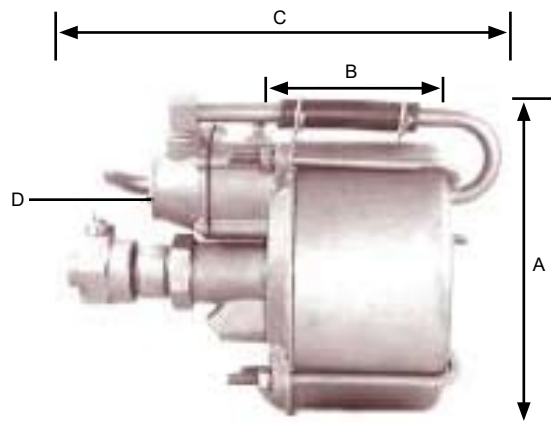

**CORE TYPE 97**

Part Number	B Vacuum Depth	C Overall Length
374550	3 3/4"	10 7/8"
378265	3 15/16"	11 3/4"
379900	3 15/16"	10 1/2"
2500521	4 3/4"	11 3/16"

NOTE: 379900 HAS PERFORATED BREATHER INSTEAD OF ATMOSPHERIC TUBE (SEE D).  
NOTE: THE FOLLOWING NUMBERS ARE SIMILAR IN APPEARANCE TO 379900 - 377869, 377870, 378003, & 378524.

M  
E  
D  
I  
U  
M  
D  
U  
T  
Y

**BENDIX HYDROVAC  
6 3/4" DIAMETER  
PIC #43**

**CORE TYPE 95**

Part Number	Vacuum Unit Depth	Overall Length	Slave Cylinder
374000	5 1/2"	14 5/8"	1
378804	5 1/2"	14 5/8"	2
2500397	5 1/2"	14 5/8"	1
2502340	4"	12"	2

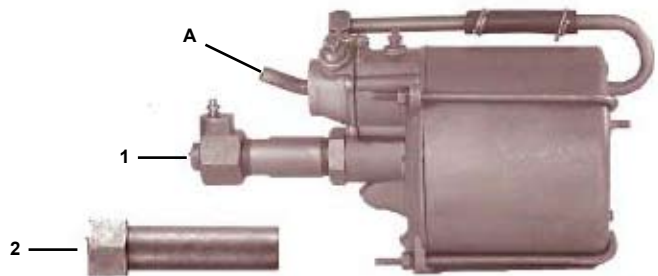

NOTE: 2500397 HAS SELF CONTAINED BREATHER INSTEAD OF TUBE (SEE A).

**BENDIX HYDROVAC  
9 1/2" DIAMETER  
PIC #44**

**CORE TYPE 97**

2501029	2502703	2508177	Description
23 5/16"	26 5/16"	23 5/16"	Overall Length
1/2" - 20	1/2" - 20	1/4" - I.F.	Input Port Size
1/2" - 20	1/2" - 20	1/4" - I.F.	Output Port Size
None	Yes	None	Reservoir Port In End Cap
Yes	None	Yes	Residual Check In Unit
1/2" Pipe	1/2" Pipe	1/2" Pipe	Vacuum Inlet Size
3/4"	1/2"	3/4"	Atmospheric Breather Stem Size



NOTE: I.F. = INVERTED FLAIR

**BENDIX HYDROVAC  
9 1/2" DIAMETER - 6 1/4" VACUUM UNIT DEPTH  
PIC #45**

**CORE TYPE 97**



Part Number	Overall Length	Vacuum Inlet Port
373853	17 1/4"	Bottom
374980	17 1/4"	Side

**BENDIX HYDROVAC  
9 1/2" DIAMETER - 9 1/4" VACUUM UNIT DEPTH  
PIC #46**

**CORE TYPE 97**



Part Number	Overall Length
374750	20"

**BENDIX VACUUM PUMP**  
PIC #50

"Repair And Return" Only

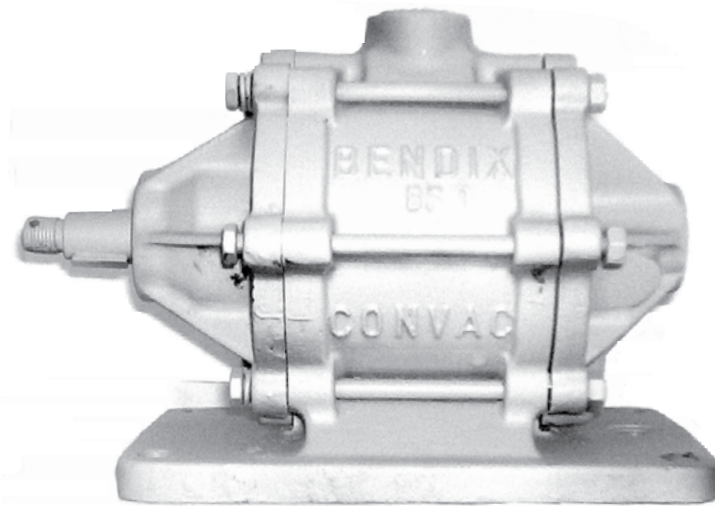

Part Number
2501000

Part No.	Pict.	Description	Wt.	Year	Application
C1TZ2005E					USE OUR NUMBER 376155
C3TZ2005C					USE OUR NUMBER 2501370
C3TZ2005J					USE OUR NUMBER 375756
<b>C4003</b>	18	Hy-Power	18	1962-60	GMC Med. Duty Truck
C4005&A					USE OUR NUMBER C4012
C4006&A					USE OUR NUMBER C4013
<b>C4007</b>	20	Hy-Power	17	1962-60	Chevrolet Med. Duty Truck
				1965-60	GMC Med. Duty Truck
				1977-61	Utility Trailers
<b>C4007F</b>	26	Hy-Power	17	1977-61	Utility Trailers
<b>C4012</b>	23	Hy-Power	21	1962-60	Chevrolet Med. Duty Truck
				1962-59	GMC Med. Duty Truck
<b>C4013</b>	28	Hy-Power	38	1962-60	Chevrolet Med. Duty Truck
				1965-60	GMC Med. Duty Truck
<b>C4021</b>	26	Hy-Power	15	1977-61	Utility Trailers
<b>C4025E</b>	6	Master Vac	16	1968-63	Ford Med. Duty Truck
<b>C4025F</b>	6	Master Vac	18	1968-63	Ford Med. Duty Truck
C4025G-J					USE OUR NUMBER C4025E
C4025H-K					USE OUR NUMBER C4025F
<b>C4026B3</b>	6	Power Sec.	12	1968-63	Ford Med. Duty Truck
<b>C4026B6</b>	6	Power Sec.	12	1968-63	Ford Med. Duty Truck
<b>C4028A</b>	6	Power Sec.	14	1968-63	Ford Med. Duty Truck
<b>C4029</b>	6	Master Vac	21	1968-63	Ford Med. Duty Truck
C4029A,B					USE OUR NUMBER C4029
C4029K					USE OUR NUMBER C4029
C4031&D					USE OUR NUMBER C4025E
C4031A					USE OUR NUMBER C4025F
<b>C4034A</b>	24	Hy-Power	19	1970-66	GMC Med. Duty Truck
<b>C4035A</b>	24	Hy-Power	21	1970-66	GMC Med. Duty Truck
<b>C4036A</b>	29	Hy-Power	36	1973-66	GMC Med. Duty Truck
C4037F					USE OUR NUMBER C4074
C4037G-N					USE OUR NUMBER C4074A OR C4074C
<b>C4037L</b>	7	Power Sec.	16	1969-67	Chevrolet Med. Duty Truck
<b>C4037NA</b>	7	Power Sec.	16	1968-67	GMC Med. Duty Truck
<b>C4037NC</b>	7	Power Sec.	16	1968-67	GMC Med. Duty Truck
<b>C4042B</b>	29	Hy-Power	34	1973-66	GMC Med. Duty Truck
C4042D					USE OUR NUMBER C4042B
C4044					USE OUR NUMBER C4063
<b>C4044D</b>	7	Power Sec.	13	1967	Ford Med. Duty Truck
C4044H					USE OUR NUMBER C4072D
C4044K					USE OUR NUMBER C4073A
<b>C4044KA</b>	7	Power Sec.	13	1976-73	Navistar Med. Duty Truck
<b>C4044KD</b>	7	Power Sec.	13	1977-68	Navistar Med. Duty Truck
C4055					USE OUR NUMBER 2503151
C4056					USE OUR NUMBER 2503139
<b>C4057</b>	30	Hy-Power	38	1968-66	Chevrolet Med. Duty Truck
<b>C4058</b>	30	Hy-Power	35	1968-66	Chevrolet Med. Duty Truck
				1971-67	GMC Med. Duty Truck
<b>C4063</b>	7	Master Vac	19	1967	Ford Med. Duty Truck
<b>C4072D</b>	7	Master Vac	26	1977-68	Navistar Med. Duty Truck
<b>C4073A</b>	7	Master Vac	25	1976-73	Navistar Med. Duty Truck
<b>C4074</b>	7	Master Vac	23	1969-67	Chevrolet Med. Duty Truck

Part No.	Pict.	Description	Wt.	Year	Application
<b>C4074A</b>	7	Master Vac	23	1968-67	GMC Med. Duty Truck
<b>C4074C</b>	7	Master Vac	23	1968-67	GMC Med. Duty Truck
C4072C-F					USE OUR NUMBER C4072D
C4074G					USE OUR NUMBER C4074
<b>C4083</b>	8	Master Vac	31	1973-68	Dodge Med. Duty Truck
C4083D					USE OUR NUMBER C4083
<b>C4083F</b>	8	Master Vac	31	1976-74	Dodge Med. Duty Truck
C4084A-B					USE OUR NUMBER C4089, C4089A, OR C4089G
<b>C4084B</b>	8	Power Sec.	20	1969-68	Chevrolet Med. Duty Truck
C4084BT					USE OUR NUMBER C4084BJ
<b>C4084BJ</b>	8	Power Sec.	20	1969-68	GMC Med. Duty Truck
<b>C4084BM</b>	8	Power Sec.	20	1969-68	GMC Med. Duty Truck
<b>C4084C</b>	8	Power Sec.	20	1977-69	Navistar Med. Duty Truck
<b>C4084E</b>	8	Power Sec.	20	1977-68	Ford Med. Duty Truck
<b>C4084H</b>	8	Power Sec.	20	1983-68	Ford Med. Duty Truck
C4084J					USE OUR NUMBER C4083 OR C4083F
<b>C4084JJ</b>	8	Power Sec.	20	1973-68	Dodge Med. Duty Truck
<b>C4084JW</b>	8	Power Sec.	20	1976-74	Dodge Med. Duty Truck
<b>C4085G</b>	8	Master Vac	31	1977-68	Ford Med. Duty Truck
<b>C4085H</b>	8	Master Vac	28	1977-68	Ford Med. Duty Truck
C4085J-N					USE OUR NUMBER C4085G
<b>C4085M</b>	8	Master Vac	31	1983-68	Ford Med. Duty Truck
<b>C4085P</b>	8	Master Vac	31	1983-68	Ford Med. Duty Truck
<b>C4089</b>	8	Master Vac	31	1969-68	Chevrolet Med. Duty Truck
<b>C4089A</b>	8	Master Vac	30	1969-68	GMC Med. Duty Truck
<b>C4089B</b>	8	Master Vac	31	1977-69	Navistar Med. Duty Truck
C4089D					USE OUR NUMBER C4089
C4089F					USE OUR NUMBER C4089B
<b>C4089G</b>	8	Master Vac	31	1969-68	GMC Med. Duty Truck
<b>C4090</b>	25	Hy-Power	29	1969-68	Chevrolet Med. Duty Truck
C4091					USE OUR NUMBER C4074A
C4091A					USE OUR NUMBER C4074C
C4091B-K					USE OUR NUMBER C4074
C4093					USE OUR NUMBER C4083
C4093C					USE OUR NUMBER C4089A
C4093D					USE OUR NUMBER C4089B
C4093E					USE OUR NUMBER C4085G
C4093F					USE OUR NUMBER C4083
C4093H					USE OUR NUMBER C4089G
C4093L					USE OUR NUMBER C4089
C4096					USE OUR NUMBER C4072D
<b>C447</b>	19	Hy-Power	19	1952-49	Ford Med. Duty Truck
<b>C448</b>	32	Hy-Power	36	1977-49	Dodge Med. Duty Truck
C448G					USE OUR NUMBER C448
C448M-R-T					USE OUR NUMBER C448
<b>C449</b>	21	Hy-Power	23	1952-46	Dodge Med. Duty Truck
<b>C462</b>	17	Hy-Power	17	1963-52	Ford Med. Duty Truck
C462C-H					USE OUR NUMBER C462
<b>C464</b>	22	Hy-Power	20	1977-52	GMC - Dodge Med. Duty Truck
C464L-R					USE OUR NUMBER C464
<b>C468</b>	16	Hy-Power	13	1959-56	Divco
<b>C4702B</b>	31	Hy-Power	39	1977-73	Utility Trailers

**M  
E  
D  
I  
U  
M  
D  
U  
T  
Y  
N  
U  
M  
E  
R  
I  
C  
A  
L**

# NUMERICAL LISTING AND INTERCHANGE FOR MEDIUM DUTY TRUCK APPLICATIONS



**MEDIUM DUTY NUMERICAL**

Part No.	Pict.	Description	Wt.	Year	Application
<b>C472A</b>	26	Hy-Power	17	1977-61	Utility Trailers
<b>C479B</b>	26	Hy-Power	22	1977-61	Utility Trailers
<b>C490</b>	16	Hy-Power	13	1977-69	Dodge Med. Duty Truck
<b>C490G</b>	16	Hy-Power	13	1977-69	Dodge Med. Duty Truck
C9HZ2005G					USE OUR NUMBER 2501350
C9TZ2005E					USE OUR NUMBER C4085G OR C4085M
C9TZ2140J					USE OUR NUMBER C4085G OR C4085M
C9TZ2140S					USE OUR NUMBER C4085G OR C4085M
D0HZ2005A					USE OUR NUMBER C4085G OR C4085M
D0HZ2005C					USE OUR NUMBER 2509605
D0HZ2140C					USE OUR NUMBER C4085P OR C4085H
D0MZ2005A					USE OUR NUMBER C4085P OR C4085H
D0TA2005C					USE OUR NUMBER 2501350
D0TA2005D					USE OUR NUMBER 2501029
D0TZ2005B					USE OUR NUMBER 2501350
D1HZ2005B					USE OUR NUMBER 2501350
D1TA2005B					USE OUR NUMBER 2501350
D1TZ2005C					USE OUR NUMBER 2509558
D1TZ2005D					USE OUR NUMBER 2501350
D1TZ2005E					USE OUR NUMBER 2501350
D2TA2005E					USE OUR NUMBER 2510065
D2TZ2005A					USE OUR NUMBER 2510065
D5HA2005A					USE OUR NUMBER 2509605
D5HA2005D					USE OUR NUMBER 2501350
D5HT2005A					USE OUR NUMBER 2509558
D5HZ2005A					USE OUR NUMBER 2509558
D5HZ2005B					USE OUR NUMBER 2509605
D5HZ2005C					USE OUR NUMBER 2510065
D5HZ2005D					USE OUR NUMBER 2501350
D5HZ2005E					USE OUR NUMBER 2501350
D5HZ2D					USE OUR NUMBER 2501350
D7HZ2005A					USE OUR NUMBER 2501350
D7HZ2005B					USE OUR NUMBER 2509558
D7TA2005A					USE OUR NUMBER 2509558
D7TA2005B					USE OUR NUMBER 2501350
D7TH2005B					USE OUR NUMBER 2501350
D7TH2005C					USE OUR NUMBER 2501350
D8HZ2005A					USE OUR NUMBER 2509558
E2HZ2005B					USE OUR NUMBER 2510065
E2HZ2005D					USE OUR NUMBER 2509558
N27269					USE OUR NUMBER 374750
<b>N4105D</b>	49	Air O/Hyd.	19	1961-47	Chevrolet Med. Duty Truck
				1961-47	Dodge Med. Duty Truck
				1963-47	Ford Med. Duty Truck
				1962-47	GMC Med. Duty Truck
				1962-47	Navistar Med. Duty Truck
TIAW2005SA					USE OUR NUMBER 374980
TWAA2005A					USE OUR NUMBER 374750
33110					USE OUR NUMBER 2503151
73358					USE OUR NUMBER 2503139
282531					USE OUR NUMBER 2501852
331100					USE OUR NUMBER 2503151

Part No.	Pict.	Description	Wt.	Year	Application
<b>373853</b>	45	Hydrovac	22	1958-45	GMC Med. Duty Truck
				1948-45	Navistar Med. Duty Truck
				1948-46	White Trucks
<b>374000</b>	27	Hydrovac	13	1964-46	Chevrolet Med. Duty Truck
				1966-49	Diamond T
				1966-55	Divco
				1964-53	Dodge Med. Duty Truck
				1964-47	Ford Med. Duty Truck
				1946	GMC Med. Duty Truck
				1962-49	Navistar Med. Duty Truck
				1966-49	White Trucks
<b>374000F</b>	43	Hydrovac	13	1959-82	Clark Equipment
				1978-62	Hyster Equipment
<b>374229</b>	46	Hydrovac	47	1959-47	Diamond T
				1961-56	Ford Med. Duty Truck
				1955-46	Mack Truck
				1971-45	Navistar Med. Duty Truck
<b>374230</b>	46	Hydrovac	52	1959-46	Diamond T
				1966-57	Mack Truck
				1971-49	Navistar Med. Duty Truck
				1959-46	White Trucks
<b>374300</b>	46	Hydrovac	44	1966-46	Diamond T
				1966-46	Mack Truck
				1966-46	White Trucks
<b>374750</b>	46	Hydrovac	25	1966-56	Chevrolet Med. Duty Truck
				1959-47	Diamond T
				1959-53	Ford Med. Duty Truck
				1966-49	GMC Med. Duty Truck
				1964-57	Mack Truck
				1971-49	Navistar Med. Duty Truck
				1959-49	White Trucks
<b>374980</b>	45	Hydrovac	22	1959-55	Chevrolet Med. Duty Truck
				1960-51	Clark Equipment
				1959-47	Diamond T
				1966-65	Ford Med. Duty Truck
				1964-48	Ford Med. Duty Truck
				1957-53	GMC Med. Duty Truck
				1982-51	Hyster Equipment
				1959-45	Mack Truck
				1959-50	Navistar Med. Duty Truck
				1959-49	White Trucks
375278					USE OUR NUMBER 374750
375279					USE OUR NUMBER 374980
<b>375440</b>	47	Air O/Hyd.	15	1961-51	Diamond T
				1959-50	Ford Med. Duty Truck
				1963-50	GMC Med. Duty Truck
				1959-50	White Trucks
<b>375680</b>	41	Hydrovac	17	1967-62	Dodge Med. Duty Truck
				1959-50	Mack Truck
				1967-50	Navistar Med. Duty Truck
375698					USE OUR NUMBER 374980
<b>375756</b>	47	Air O/Hyd.	14	1963-51	Chevrolet Med. Duty Truck

Part No.	Pict.	Description	Wt.	Year	Application
				1960	Dodge Med. Duty Truck
				1967-54	Ford Med. Duty Truck
				1961-60	GMC Med. Duty Truck
				1958	Mack Truck
				1967-56	Navistar Med. Duty Truck
<b>375757</b>	47	Air O/Hyd.	16	1961-51	Diamond T
				1967-56	Navistar Med. Duty Truck
<b>375844</b>	47	Air O/Hyd.	15	1962-51	Diamond T
				1965-51	Navistar Med. Duty Truck
				1962	White Trucks
<b>375901</b>	47	Air O/Hyd.	14	1961-60	Chevrolet Med. Duty Truck
				1961-60	GMC Med. Duty Truck
				1963-62	Navistar Med. Duty Truck
<b>376155</b>	41	Hydrovac	18	1962-51	Diamond T
				1962	White Trucks
<b>376440</b>	47	Air O/Hyd.	15	1957-53	GMC Med. Duty Truck
<b>376500</b>	38	Hydrovac	9	1956-51	Chevrolet Med. Duty Truck
<b>376504</b>	47	Air O/Hyd.	14	1967-62	Dodge Med. Duty Truck
				1961-58	Mack Truck
<b>376658</b>	46	Hydrovac	47	1955-54	Ford Med. Duty Truck
377042					USE OUR NUMBER 374750
377475					USE OUR NUMBER 374000
377600					USE OUR NUMBER 379900
<b>377839</b>	46	Hydrovac	47	1971-56	Dodge Med. Duty Truck
378802					USE OUR NUMBER 374000
<b>378804</b>	43	Hydrovac	13	1965-60	Navistar Med. Duty Truck
379474					USE OUR NUMBER 374000
464322					USE OUR NUMBER 374980
688421					USE OUR NUMBER 376155
691294					USE OUR NUMBER 2503123
691295					USE OUR NUMBER 2503123
756251					USE OUR NUMBER 374000
1702292					USE OUR NUMBER 2503151
2006731					USE OUR NUMBER 2503139
2006732					USE OUR NUMBER 2503139
2006733					USE OUR NUMBER 2503139
2208488					USE OUR NUMBER 374000
2239520					USE OUR NUMBER 374750
2241895					USE OUR NUMBER 374980
2255816					USE OUR NUMBER 374750
2259580					USE OUR NUMBER 374980
2419901					USE OUR NUMBER 375756
<b>2500086</b>	47	Air O/Hyd.	15	1962-60	Chevrolet Med. Duty Truck
<b>2500087</b>	47	Air O/Hyd.	15	1962-60	Chevrolet Med. Duty Truck
2500137					USE OUR NUMBER 2500086
2500138					USE OUR NUMBER 2500087
<b>2500187</b>	48	Air Minipak	9	1966-64	Dodge Med. Duty Truck
				1964-60	Navistar Med. Duty Truck
<b>2500397</b>	43	Hydrovac	12	1965-52	Chevrolet Med. Duty Truck
				1966-53	Ford Med. Duty Truck
				1966-52	GMC Med. Duty Truck
2500420					USE OUR NUMBER 2500660

Part No.	Pict.	Description	Wt.	Year	Application
2500487					USE OUR NUMBER 377839
<b>2500506</b>	48	Air Minipak	9	1967-60	Diamond T
				1962-60	Mack Truck
				1967-60	White Trucks
2500517					USE OUR NUMBER 375680
<b>2500521</b>	42	Master Vac	12	1967-61	Ford Med. Duty Truck
2500631					USE OUR NUMBER 379900
<b>2500660</b>	39	Hydrovac	14	1962-60	Chevrolet Med. Duty Truck
2500685					USE OUR NUMBER 375440
2500690					USE OUR NUMBER 375756
2500695					USE OUR NUMBER 375757
2500700					USE OUR NUMBER 375901
2500710					USE OUR NUMBER 376504
2500715					USE OUR NUMBER 2500735
2500720					USE OUR NUMBER 376504
<b>2500735</b>	47	Air O/Hyd.	14	1962-58	GMC Med. Duty Truck
2501001					USE OUR NUMBER 376155
<b>2501029</b>	44	Hydrovac	25	1971-62	Ford Med. Duty Truck
2501210					USE OUR NUMBER 2501625
2501281					USE OUR NUMBER 2502703
2501310					USE OUR NUMBER 2502703
<b>2501350</b>	33	Hydrovac	24	1983-61	Ford Med. Duty Truck
<b>2501370</b>	33	Hydrovac	17	1967-62	Ford Med. Duty Truck
<b>2501424</b>	40	Hydrovac	16	1967-62	Ford Med. Duty Truck
2501503					USE OUR NUMBER 2500506
<b>2501625</b>	33	Hydrovac	24	1965-62	Navistar Med. Duty Truck
2501666					USE OUR NUMBER 2502703
<b>2501847</b>	34	Hydrovac	20	1965-62	Chevrolet Med. Duty Truck
				1966-62	GMC Med. Duty Truck
				1971-65	Navistar Med. Duty Truck
<b>2501850</b>	34	Hydrovac	24	NLA	USE OUR NUMBER 2501350
2501851					USE OUR NUMBER 2501852
<b>2501852</b>	35	Hydrovac	38	1965-62	Chevrolet Med. Duty Truck
				1965-62	GMC Med. Duty Truck
<b>2501975</b>	47	Air O/Hyd.	17	1963-62	Ford Med. Duty Truck
<b>2502061</b>	47	Air O/Hyd.	17	1965-63	Chevrolet Med. Duty Truck
				1965-63	GMC Med. Duty Truck
<b>2502062</b>	47	Air O/Hyd.	17	1965-63	Chevrolet Med. Duty Truck
				1965-63	GMC Med. Duty Truck
2502075					USE OUR NUMBER 2501847
2502076					USE OUR NUMBER 2503139
2502077					USE OUR NUMBER 2501852
2502078					USE OUR NUMBER 2501852
2502107					USE OUR NUMBER 2502061
2502108					USE OUR NUMBER 2502062
<b>2502119</b>	39	Hydrovac	14	1973-62	Navistar Med. Duty Truck
2502281					USE OUR NUMBER 2502703
2502536					USE OUR NUMBER 2500187
2502602					USE OUR NUMBER 2502703
2502646					USE OUR NUMBER 2502703
<b>2502702</b>	48	Air Minipak	9	1967-63	Dodge Med. Duty Truck
<b>2502703</b>	44	Hydrovac	25	1965-62	Navistar Med. Duty Truck

**M  
E  
D  
I  
U  
M  
D  
U  
T  
Y  
N  
U  
M  
E  
R  
I  
C  
A  
L**

# NUMERICAL LISTING AND INTERCHANGE FOR MEDIUM DUTY TRUCK APPLICATIONS



**M  
E  
D  
I  
U  
M  
D  
U  
T  
Y  
T  
R  
U  
C  
K  
A  
P  
P  
L  
I  
C  
A  
T  
I  
O  
N  
S**

Part No.	Pict.	Description	Wt.	Year	Application
2502869					USE OUR NUMBER 2502982
<b>2502982</b>	48	Hydrovac	23	1980-63	Navistar Med. Duty Truck
2503098					USE OUR NUMBER 2503123
<b>2503123</b>	35	Hydrovac	38	1983-65	Chevrolet Med. Duty Truck 1983-65 GMC Med. Duty Truck
<b>2503139</b>	34	Hydrovac	24	1984-65	Chevrolet Med. Duty Truck 1984-65 GMC Med. Duty Truck
<b>2503151</b>	34	Hydrovac	24	1967-65	Chevrolet Med. Duty Truck 1982-65 Clark Equipment 1971-65 GMC Med. Duty Truck
<b>2503230</b>	48	Air Minipak	9	1967-64	Navistar Med. Duty Truck
2503258					USE OUR NUMBER 2501350
2503259					USE OUR NUMBER 2501370
2503566					USE OUR NUMBER 2500187
2504052					USE OUR NUMBER 2502982
2504055					USE OUR NUMBER 2502982
2504102					USE OUR NUMBER 2501847
2504105					USE OUR NUMBER 2501625
2504106					USE OUR NUMBER 2501852
2504109					USE OUR NUMBER 2501852
2504113					USE OUR NUMBER 25013139
2504114					USE OUR NUMBER 2503139
2504151					USE OUR NUMBER 2504188
<b>2504183</b>	47	Air O/Hyd.	16	1967-66	Chevrolet Med. Duty Truck
<b>2504184</b>	47	Air O/Hyd.	16	1966	Chevrolet Med. Duty Truck 1967-66 GMC Med. Duty Truck
2504187					USE OUR NUMBER 2501847
<b>2504188</b>	34	Hydrovac	24	1966-65	Navistar Med. Duty Truck
2504303					USE OUR NUMBER 2503151
2504304					USE OUR NUMBER 2503139
2504305					USE OUR NUMBER 2503123
2504306					USE OUR NUMBER 2503123
2504398					USE OUR NUMBER 2504183
2504399					USE OUR NUMBER 2504184
2504615					USE OUR NUMBER 2506209
2504616					USE OUR NUMBER 2508065
2505479					USE OUR NUMBER 2503123
2505516					USE OUR NUMBER 2504184
<b>2506209</b>	35	Hydrovac	37	1967	Navistar Med. Duty Truck
<b>2507224</b>	35	Hydrovac	38	1971-68	Ford Med. Duty Truck
2507376					USE OUR NUMBER 2509140
2507377					USE OUR NUMBER 2509149
2507378					USE OUR NUMBER 2509149
2507379					USE OUR NUMBER 2509149
2507860					USE OUR NUMBER 2508059
2508014					USE OUR NUMBER 2509140
<b>2508059</b>	34	Hydrovac	25	1978-68	Navistar Med. Duty Truck
<b>2508065</b>	35	Hydrovac	36	1980-68	Navistar Med. Duty Truck
<b>2508177</b>	44	Hydrovac	25	1971-70	Ford Med. Duty Truck
<b>2508557</b>	1	Master Vac	18	1977-73	Dodge Med. Duty Truck
2508597					USE OUR NUMBER 2508819
2508643					USE OUR NUMBER 2503123

Part No.	Pict.	Description	Wt.	Year	Application
<b>2508819</b>	33	Hydrovac	23	1978-69	Navistar Med. Duty Truck
2508827					USE OUR NUMBER 2503139
2508829					USE OUR NUMBER 2503139
2508971					USE OUR NUMBER 2509265
<b>2509140</b>	36	Hydrovac	52	1973-68	Ford Med. Duty Truck
2509143					USE OUR NUMBER 2509149
2509146					USE OUR NUMBER 2509149
<b>2509149</b>	36	Hydrovac	52	1973-68	Ford Med. Duty Truck
2509152					USE OUR NUMBER 2509140
2509278					USE OUR NUMBER 2503139
2509364					USE OUR NUMBER 2501350
2509426					USE OUR NUMBER 2501029
2509454					USE OUR NUMBER 2509265
2509493					USE OUR NUMBER 2510237
2509547					USE OUR NUMBER 2501350
<b>2509558</b>	34	Hydrovac	24	1983-71	Ford Med. Duty Truck
2509559					USE OUR NUMBER 2501350
<b>2509605</b>	35	Hydrovac	37	1983-71	Ford Med. Duty Truck
2509616					USE OUR NUMBER 2501847
<b>2509768</b>	1	Master Vac	17	1975-72	Navistar Med. Duty Truck
2509870					USE OUR NUMBER 2508065
<b>2510027</b>	34	Hydrovac	24	1984-77	Chevrolet Med. Duty Truck 1977-71 Dodge Med. Duty Truck 1984-77 GMC Med. Duty Truck
<b>2510033</b>	1	Master Vac	18	1978	Dodge Med. Duty Truck
<b>2510065</b>	34	Hydrovac	25	1983-70	Ford Med. Duty Truck
<b>2510088</b>	1	Master Vac	17	1973-71	Dodge Med. Duty Truck
2510118					USE OUR NUMBER 2510122
2510241					USE OUR NUMBER 2501847
<b>2510296</b>	33	Hydrovac	23	1980-72	Navistar Med. Duty Truck
2510382					USE OUR NUMBER 2509265
2510400					USE OUR NUMBER 2503123
2510401					USE OUR NUMBER 2503123
2510640					USE OUR NUMBER 2501847
<b>2510680</b>	1	Master Vac	19	1978-73	Dodge Med. Duty Truck
<b>2510813</b>	34	Hydrovac	21	1977-73	Dodge Med. Duty Truck
2511098					USE OUR NUMBER 2501350
2511170					USE OUR NUMBER 2510065
2511171					USE OUR NUMBER 2501350
2511172					USE OUR NUMBER 2501350
2511173					USE OUR NUMBER 2509558
2511174					USE OUR NUMBER 2509605
2511306					USE OUR NUMBER 2510680
2512059					USE OUR NUMBER 2508059
2512060					USE OUR NUMBER 2508819
2512061					USE OUR NUMBER 2510296
2512062					USE OUR NUMBER 2510027
2512063					USE OUR NUMBER 2510813
2512064					USE OUR NUMBER 2503139
2512065					USE OUR NUMBER 2503139
2512066					USE OUR NUMBER 2503139
2512076					USE OUR NUMBER 2502982

Part No.	Pict.	Description	Wt.	Year	Application
2512138					USE OUR NUMBER 2510065
2512139					USE OUR NUMBER 2509558
2512140					USE OUR NUMBER 2501350
2512141					USE OUR NUMBER 2501350
2512142					USE OUR NUMBER 2509605
2512189					USE OUR NUMBER 2501350
2512190					USE OUR NUMBER 2509558
2512569					USE OUR NUMBER 2501350
2512570					USE OUR NUMBER 2509558
2513026					USE OUR NUMBER 2510065
2513171					USE OUR NUMBER 2502982
2513491					USE OUR NUMBER 2513493
<b>2513492</b>	33	Hydrovac	23	1984-81	Navistar Med. Duty Truck
<b>2513493</b>	33	Hydrovac	37	1981	Navistar Med. Duty Truck
<b>2513494</b>	33	Hydrovac	23	1984-81	Navistar Med. Duty Truck
2513811					USE OUR NUMBER 2503123
2513813					USE OUR NUMBER 2503139
2513814					USE OUR NUMBER 2503139
2513815					USE OUR NUMBER 2503139
2514916					USE OUR NUMBER 2501847,2503151, 2503151 or 2510813 (DEPENDING ON APPLICATION)
2514917					USE OUR NUMBER 375680, 2501625, OR 2502982 (DEPENDING ON APPLICATION)
2514918					USE OUR NUMBER 2510065
2514919					USE OUR NUMBER 2501852, 2503123, OR 2508065 (DEPENDING ON APPLICATION)
2514920					USE OUR NUMBER 2501350
2515029					USE OUR NUMBER 2510296 OR 2513492 (DEPENDING ON APPLICATION)
2515030					USE OUR NUMBER 2510065
2515050					USE OUR NUMBER 2503139, IF GM
2623435		CASTING #			USE 7700438 OR 7700439
2623501					USE OUR NUMBER 7700435
2515074					USE OUR NUMBER 2503139
<b>2700151</b>	2	Master Vac	19	1975-73	Ford Med. Duty Truck
<b>2700152</b>	1	Master Vac	19	1975-74	Ford Med. Duty Truck
2700176					USE OUR NUMBER 2700221
<b>2700194</b>		Hyd. Boost	21	1978-73	Dodge Med. Duty Truck
2700195					USE OUR NUMBER 2700194
2700196					USE OUR NUMBER 2700194
2700199					USE OUR NUMBER 2700194
<b>2700204</b>	1	Master Vac	16	1982-72	Clark Equipment
<b>2700217</b>	4,5	Master Vac	14	1982-79	Dodge Med. Duty Truck
2700211					USE OUR NUMBER 2510033
2700214					USE OUR NUMBER 2700194
<b>2700219</b>	1	Master Vac	12	1982-79	Dodge Med. Duty Truck
<b>2700221</b>	3	Master Vac	26	1982-77	Dodge Med. Duty Truck
2700222					USE OUR NUMBER 2700217

Part No.	Pict.	Description	Wt.	Year	Application
<b>2700223</b>	1	Master Vac	15	1982-79	Dodge Med. Duty Truck
<b>2700243</b>		Hyd. Boost	21	1980	Dodge Med. Duty Truck
2700249					USE OUR NUMBER 2700243
<b>2700272</b>	9	Hydromax	18	1983-80	Ford Med. Duty Truck
<b>2700273</b>	9	Hydromax	18	1997-84	Ford Med. Duty Truck
<b>2700278</b>	9	Hydromax	18	1983-80	Ford Med. Duty Truck
<b>2700350</b>	9	Hydromax	18	1997-84	Ford Med. Duty Truck
<b>2700351</b>	9	Hydromax	18	1986-84	Navistar Med. Duty Truck
<b>2700380</b>	9	Hydromax	18	1989-88	Navistar Med. Duty Truck
<b>2700383</b>	37	Hydrovac	24	ALL	Utility Trailers
<b>2700384</b>	37	Hydrovac	24	ALL	Utility Trailers
<b>2700385</b>	37	Hydrovac	24	ALL	Utility Trailers
<b>2700394</b>	9	Hydromax	18	2000-90	Navistar Med. Duty Truck
<b>2700395</b>	9	Hydromax	18	2000-90	Navistar Med. Duty Truck
<b>2700613</b>	9	Hydromax	18	1997-92	Ford Med. Duty Truck
<b>2700615</b>	9	Hydromax	18	1995-92	Ford Med. Duty Truck
2770212					USE OUR NUMBER 3700221
2770725					USE OUR NUMBER 3700194
2770916					USE OUR NUMBER 3700194
2771173					USE OUR NUMBER 3700194
2770221					USE OUR NUMBER 3700273
2770255					USE OUR NUMBER 3700273
2770256					USE OUR NUMBER 3700350
2770454					USE OUR NUMBER 3700380
2770927					USE OUR NUMBER 3700273
2771293					USE OUR NUMBER 3700273
<b>2771320</b>	<b>10</b>				<b>MOTOR - HYDRO MAX</b>
2771371					USE OUR NUMBER 3700273
<b>2771420</b>	<b>10</b>				<b>MOTOR - HYDRO MAX</b>
2771424					USE OUR NUMBER 3700350
2770468					USE OUR NUMBER 3700273
2771494					USE OUR NUMBER 2771420
2771544					USE OUR NUMBER 2771320
2771552					USE OUR NUMBER 3700394
2771558					USE OUR NUMBER 3700273
2771559					USE OUR NUMBER 3700350
2771897					USE OUR NUMBER 3700625
2772114					USE OUR NUMBER 3700625
2772181					USE OUR NUMBER 3700625
2772181					USE OUR NUMBER 3700625
2772184					USE OUR NUMBER 3700625
2772275					USE OUR NUMBER 3700273
2772350					USE OUR NUMBER 3700273
<b>2772729</b>	<b>10</b>				<b>MOTOR - HYDRO MAX</b>
2772817					USE OUR NUMBER 3700625
2772884					USE OUR NUMBER 3700273
2772937					USE OUR NUMBER 3700625
2823532					USE OUR NUMBER 2501852
2823676					USE OUR NUMBER 2501847
2823677					USE OUR NUMBER 2503139
2823678					USE OUR NUMBER 2501852
2823679					USE OUR NUMBER 2501852

**MEDIUM DUTY NUMERICAL**

# NUMERICAL LISTING AND INTERCHANGE FOR MEDIUM DUTY TRUCK APPLICATIONS



**MEDIUM DUTY NUMERICAL**

Part No.	Pict.	Description	Wt.	Year	Application
3380385					USE OUR NUMBER 2503139
3380386					USE OUR NUMBER 2503123
3380387					USE OUR NUMBER 2503123
3380388					USE OUR NUMBER 2503123
3380389					USE OUR NUMBER 2503123
<b>3508557</b>	1	Power Sec.	11	1977-73	Dodge Med. Duty Truck
<b>3509768</b>	1	Power Sec.	11	1975-72	Navistar Med. Duty Truck
<b>3510033</b>	1	Power Sec.	11	1978	Dodge Med. Duty Truck
<b>3510680</b>	1	Power Sec.	11	1978-71	Dodge Med. Duty Truck
<b>3700152</b>	1	Power Sec.	11	1975-74	Ford Med. Duty Truck
<b>3700194</b>		Power Sec.	14	1978-73	Dodge Med. Duty Truck
<b>3700204</b>	1	Power Sec.	11	1961-60	Clark Equipment
<b>3700217</b>	4,5	Power Sec.	11	1982-79	Dodge Med. Duty Truck
<b>3700219</b>	1	Power Sec.	11	1982-79	Dodge Med. Duty Truck
<b>3700221</b>	3	Power Sec.	14	1982-75	Dodge Med. Duty Truck
<b>3700223</b>	1	Power Sec.	11	1982-79	Dodge Med. Duty Truck
<b>3700243</b>		Power Sec.	14	1980	Dodge Med. Duty Truck
<b>3700273</b>	9	Power Sec.	6	1999-80	Ford Med. Duty Truck
<b>3700350</b>	9	Power Sec.	6	1999-84	Ford Med. Duty Truck
				1986-84	Navistar Med. Duty Truck
<b>3700380</b>	9	Power Sec.	6	1989-88	Navistar Med. Duty Truck
<b>3700394</b>	9	Power Sec.	6	2000-90	Navistar Med. Duty Truck
<b>3700625</b>	9	Power Sec.	6	2000-90	Navistar Med. Duty Truck
3727820					USE OUR NUMBER 374000
3761237					USE OUR NUMBER 374000
3782162					USE OUR NUMBER 374000
3785516					USE OUR NUMBER 2500660
3786458					USE OUR NUMBER 2500660
3823529					USE OUR NUMBER 2501847
3823530					USE OUR NUMBER 2503139
3874183					USE OUR NUMBER 2501847
3874184					USE OUR NUMBER 2503139
3874185					USE OUR NUMBER 2501852
3874186					USE OUR NUMBER 2501852
3874187					USE OUR NUMBER 2501847
3874188					USE OUR NUMBER 2501852
3874189					USE OUR NUMBER 2501852
3874190					USE OUR NUMBER 2501852
3880384					USE OUR NUMBER 2503139
3882288					USE OUR NUMBER 2503151
3882289					USE OUR NUMBER 2503151
3905125					USE OUR NUMBER 2503123
3954047					USE OUR NUMBER 2503139
3959742					USE OUR NUMBER 2503123
3965337					USE OUR NUMBER 2503139
3965388					USE OUR NUMBER 2503139
4030333					USE OUR NUMBER 2510027
4030334					USE OUR NUMBER 2510813
4150982					USE OUR NUMBER 2501847,2503151, 2503151 or 2510813 (DEPENDING ON APPLICATION)
4150983					USE OUR NUMBER 375680,

Part No.	Pict.	Description	Wt.	Year	Application
					2501625, OR 2502982 (DEPENDING ON APPLICATION)
4150984					USE OUR NUMBER 2510065
4150985					USE OUR NUMBER 2501852, 2503123, OR 2508065 (DEPENDING ON APPLICATION)
4151108					USE OUR NUMBER 2501350
4151217					USE OUR NUMBER 2510296 OR 2513492 (DEPENDING ON APPLICATION)
4151219					USE OUR NUMBER 2510065
4151228					USE OUR NUMBER 2503139
4151228					USE OUR NUMBER 2509558
4151229					USE OUR NUMBER 2503139
6263439					USE OUR NUMBER 2503151
6700435					USE OUR NUMBER 7700435
6700436					USE OUR NUMBER 7700436
6700437					USE OUR NUMBER 7700437
6700438					USE OUR NUMBER 7700438
6700439					USE OUR NUMBER 7700439
<b>7700435</b>	14	Dual Power	6	1987-74	Chevrolet Med. Duty Truck
				1987-74	GMC Med. Duty Truck
				1987-73	Navistar Med. Duty Truck
<b>7700436</b>	14	Power Sec.	6	1987-74	Chevrolet Med. Duty Truck
				1987-74	GMC Med. Duty Truck
				1987-73	Navistar Med. Duty Truck
<b>7700437</b>	14	Power Sec.	6	1987-74	Chevrolet Med. Duty Truck
				1987-74	GMC Med. Duty Truck
				1987-73	Navistar Med. Duty Truck
<b>7700438</b>	12	Hy-Power	18	1989-84	Chevrolet Med. Duty Truck
				1989-84	GMC Med. Duty Truck
				1990-78	Navistar Med. Duty Truck
<b>7700439</b>	12	Hy-Power	18	1989-84	Chevrolet Med. Duty Truck
				1989-84	GMC Med. Duty Truck
				1990-78	Navistar Med. Duty Truck
<b>7700556</b>	12	Hy-Power	18	1996-90	Chevrolet Med. Duty Truck
				1996-90	GMC Med. Duty Truck
				1990-78	Navistar Med. Duty Truck
<b>7700559</b>	12	Hy-Power	18	1996-90	Chevrolet Med. Duty Truck
				1996-90	GMC Med. Duty Truck
				1990-78	Navistar Med. Duty Truck
7700624					USE OUR NUMBER 3700625

## INTERCHANGE NUMBER SECTION

OEM & DEALER NUMBER		PRIOR PART NUMBER	OEM & DEALER NUMBER		PRIOR PART NUMBER	OEM & DEALER NUMBER		PRIOR PART NUMBER
178-462	USE	7700515	178-532	USE	3700540	178-630	USE	6700609
178-463	USE	7700530	178-533	USE	3700534	178-631	USE	6700608
178-464	USE	7700544	178-534	USE	6700590	178-632	USE	6700589
178-465	USE	7700532	178-535	USE	3700531	178-633	USE	6700593
178-466	USE	7700523	178-536	USE	3700537	178-634	USE	6700620
178-466	USE	7700523	178-537	USE	3700536	178-635	USE	6700577
178-469	USE	7700605	178-538	USE	3700269	178-636	USE	6700569
178-471	USE	7700503	178-539	USE	3700550	178-637	USE	6700621
178-473	USE	7700513	178-540	USE	3700551	10097670	USE	7700443
178-474	USE	7700520	178-541	USE	3700306	10097674	USE	7700443
178-475	USE	7700551	178-542	USE	3700461	10097697	USE	7700483
178-476	USE	7700552	178-543	USE	3700167	10112685	USE	7700417
178-477	USE	7700539	178-545	USE	3700274	10132876	USE	7700443
178-479	USE	7700581	178-546	USE	3700274	10165315	USE	7700536
178-480	USE	6700580	178-547	USE	3700336	10165339	USE	7700535
178-480	USE	6700580	178-552	USE	9700701	10242104	USE	6700590
178-481	USE	7700603	178-553	USE	9700512	10253643	USE	6700590
178-482	USE	7700563	178-556	USE	9700511	12388529	USE	3700546
178-483	USE	7700575	178-557	USE	9700510	12542223	USE	3700550
178-484	USE	7700600	178-558	USE	9700703	12542224	USE	3700551
178-485	USE	6700602	178-559	USE	9700702	14019978	USE	3700306
178-487	USE	7700581	178-560	USE	9700509	14022299	USE	3700461
178-488	USE	7700550	178-561	USE	9700515	14024422	USE	3700167
178-490	USE	6700588	178-566	USE	3700526	14055057	USE	3700274
178-491	USE	7700586	178-567	USE	3700533	15504316	USE	2503123
178-492	USE	7700550	178-568	USE	3700539	15504317	USE	2503139
178-494	USE	7700520	178-569	USE	3700547	15515476	USE	2503123
178-495	USE	6700588	178-571	USE	3700544	15515478	USE	2503139
178-496	USE	6700613	178-572	USE	3700545	15515479	USE	2503139
178-497	USE	6700616	178-573	USE	3700546	15521935	USE	3700274
178-498	USE	6700598	178-575	USE	3700530	15597788	USE	3700336
178-499	USE	7700524	178-600	USE	7700532	15607066	USE	3700377
178-508	USE	9700515	178-601	USE	7700523	15607067	USE	3700422
178-509	USE	7700443	178-602	USE	7700586	15635043	USE	3700421
178-511	USE	7700443	178-603	USE	6700561	15650151	USE	3700397
178-512	USE	7700417	178-604	USE	7700491	15688264	USE	3700527
178-513	USE	7700497	178-605	USE	6700597	15691853	USE	3700529
178-514	USE	7700495	178-606	USE	7700574	15691854	USE	3700532
178-515	USE	7700443	178-607	USE	6700571	15691855	USE	3700535
178-516	USE	7700483	178-609	USE	6700598	15693118	USE	3700540
178-517	USE	6700487	178-610	USE	6700602	15693119	USE	3700534
178-518	USE	6700486	178-611	USE	6700614	15710165	USE	3700531
178-520	USE	3700422	178-612	USE	6700587	15710166	USE	3700537
178-521	USE	3700421	178-613	USE	6700610	15710167	USE	3700536
178-523	USE	7700536	178-614	USE	6700611	15953996	USE	3700537
178-524	USE	7700535	178-615	USE	6700613	15965391	USE	3700526
178-525	USE	3700377	178-616	USE	6700616	15969686	USE	3700533
178-526	USE	3700397	178-620	USE	6700619	15969687	USE	3700539
178-527	USE	6700590	178-621	USE	6700607	15997191	USE	3700547
178-528	USE	3700527	178-622	USE	6700565	18001029	USE	7700438
178-529	USE	3700529	178-624	USE	6700612	18001047	USE	7700435
178-530	USE	3700532	178-625	USE	6700576	18001072	USE	7700436
178-531	USE	3700535	178-628	USE	6700617	18001073	USE	7700437

## INTERCHANGE NUMBER SECTION

OEM & DEALER NUMBER	PRIOR PART NUMBER	OEM & DEALER NUMBER	PRIOR PART NUMBER	OEM & DEALER NUMBER	PRIOR PART NUMBER
18001148	USE 7700439	18008521	USE 7700328	18015765	USE 7700556 OR 7700439
18001229	USE 7700438	18008773	USE 7700436	18015776	USE 6700974
18001304	USE 7700236	18008972	USE 7700435 & 7700436	18015784	USE 7700452
18001810	USE 7700439			18015786	USE 7700452
18001812	USE 6700974	18008973	USE 7700436	18015835	USE 7700548
18002050	USE 7700212	18008974	USE 7700435	18015930	USE 7700387
18003144	USE 7700437	18009730	USE 7700395	18015932	USE 7700277
18003669	USE 7700218	18009853	USE 7700328	18015935	USE 7700212
18003670	USE 7700267	18010034	USE 7700345	18015936	USE 7700413
18003670	USE 7700293	18010041	USE 7700346	18015939	USE 7700318
18003675	USE 7700233	18010120	USE 7700320	18015940	USE 7700415
18003676	USE 7700276	18010209	USE 7700347	18015941	USE 7700293
18003678	USE 7700163	18010390	USE 7700387	18015944	USE 7700276
18003680	USE 7700277	18010437	USE 7700293	18015959	USE 7700467
18003681	USE 7700163	18010579	USE 7700274	18015980	USE 7700421
18003685	USE 7700218	18010580	USE 7700275	18016049	USE 7700218
18003686	USE 7700163	18010581	USE 7700286	18016050	USE 7700321
18003687	USE 7700154	18010582	USE 7700291	18016051	USE 7700423
18003814	USE 7700277	18010911	USE 7700326	18016052	USE 7700366
18003815	USE 7700233	18011248	USE 7700439	18016053	USE 7700236
18003828	USE 7700236	18011339	USE 7700377	18016057	USE 7700163
18003829	USE 7700258	18011482	USE 7700439	18016058	USE 7700288
18003892	USE 7700233	18011749	USE 7700423	18016059	USE 7700236
18003895	USE 7700234	18011750	USE 7700422	18016063	USE 7700241
18003914	USE 7700254	18012101	USE 7700424	18016064	USE 7700163
18003998	USE 7700438	18012115	USE 7700463	18016066	USE 7700233
18004082	USE 7700258	18012148	USE 7700439	18016069	USE 7700218
18004083	USE 7700234	18012157	USE 7700417	18016255	USE 7700414
18004085	USE 7700159	18012330	USE 7700439	18016257	USE 7700478
18004086	USE 7700261	18012767	USE 7700415	18016259	USE 7700506
18004365	USE 7700281	18012768	USE 7700415	18016261	USE 7700527
18004527	USE 7700439	18012882	USE 7700395	18016409	USE 7700477
18004550	USE 7700344	18013061	USE 7700544	18016443	USE 7700424
18005050	USE 7700236	18013153	USE 7700433	18016493	USE 7700491
18005074	USE 7700212	18013154	USE 7700424	18016702	USE 7700421
18005076	USE 7700241	18013155	USE 7700414	18017044	USE 7700417
18005532	USE 7700236	18013157	USE 7700417	18017158	USE 7700509
18005533	USE 7700236	18013867	USE 7700425	18017187	USE 7700556
18005539	USE 7700435	18013875	USE 7700421	18017215	USE 7700521
18006232	USE 7700439	18013986	USE 7700494	18017254	USE 7700519
18006497	USE 7700277	18014080	USE 7700556	18017407	USE 7700522
18006555	USE 7700276	18014326	USE 7700543	18017460	USE 7700335
18006566	USE 7700283	18014641	USE 7700553	18017552	USE 7700521
18006574	USE 7700289	18014832	USE 7700447	18017728	USE 7700504
18006575	USE 7700290	18014925	USE 7700460	18017729	USE 7700505
18006577	USE 7700291	18014931	USE 7700458	18017730	USE 7700556
18006856	USE 7700293	18014955	USE 7700459	18017750	USE 7700511
18006974	USE 6700974	18015135	USE 7700546	18017847	USE 7700503
18007257	USE 7700295	18015319	USE 7700344	18017901	USE 6700571
18007292	USE 7700318	18015332	USE 7700258	18018077	USE 7700439
18007368	USE 6700974	18015333	USE 7700310	18018131	USE 7700439
18007661	USE 7700329	18015380	USE 7700524	18018132	USE 7700556
18008289	USE 7700288				

## INTERCHANGE NUMBER SECTION

OEM & DEALER NUMBER		PRIOR PART NUMBER	OEM & DEALER NUMBER		PRIOR PART NUMBER	OEM & DEALER NUMBER		PRIOR PART NUMBER
18018242	USE	7700539	18029874	USE	6700608	875393R92	USE	2501625
18018266	USE	7700517	18029877	USE	6700620	875423R92	USE	2502703
18018447	USE	7700538	18029879	USE	6700569	95367R91	USE	375680
18018485	USE	7700520	18029921	USE	6700576	967547R91	USE	2500660
18018488	USE	7700581	18029959	USE	6700565	967547R92	USE	2500660
18018622	USE	7700551	18029961	USE	6700612	F7UZ2005CB	USE	3700687
18018721	USE	6700580	18029974	USE	7700290	1700100	USE	---
18018772	USE	7700605	18029975	USE	6700571			
18018921	USE	7700603	18029976	USE	7700581			
18018941	USE	7700563	18029977	USE	6700580			
18018977	USE	7700530	18029978	USE	7700603			
18019187	USE	7700575	18029979	USE	7700563			
18019236	USE	7700515	18029981	USE	7700581			
18019298	USE	7700600	18029982	USE	7700550			
18019352	USE	7700556	18029985	USE	6700610			
18019415	USE	6700602	18029986	USE	6700611			
18019512	USE	7700523	18029987	USE	6700561			
18019576	USE	7700556	18029988	USE	7700520			
18019639	USE	6700974	18029989	USE	7700574			
18019963	USE	7700552	18029990	USE	6700587			
18019996	USE	7700581	18029999	USE	6700607			
18020000	USE	7700550	2623435	USE	7700438 OR 7700439			
18020022	USE	7700513	91171392	USE	9700701			
18020166	USE	7700523	94108912	USE	9700512			
18020202	USE	6700610	94480240	USE	6700486			
18020203	USE	6700611	94847510	USE	9700511			
18020294	USE	6700561	94851269	USE	9700510			
18020298	USE	6700588	94853018	USE	9700703			
18020351	USE	7700524	94854114	USE	9700702			
18020388	USE	7700532	96058725	USE	9700515			
18020521	USE	7700523	96060621	USE	9700509			
18020522	USE	7700586	96064817	USE	9700515			
18020555	USE	7700550	221455R91	USE	378804			
18020627	USE	7700586	277082C92	USE	2502982			
18020710	USE	7700556	277082C93	USE	2502982			
18020889	USE	7700520	291541C91	USE	2504188			
18020892	USE	6700588	315669C91	USE	2506209			
18020900	USE	7700539	315670C91	USE	2508065			
18021125	USE	6700613	365263C92	USE	2508059			
18021125	USE	7700556	383195C91	USE	2508819			
18021126	USE	6700616	383195C92	USE	2508819			
18021127	USE	6700598	419168C91	USE	2513494			
18021298	USE	7700574	430280C92	USE	2510296			
18021298	USE	7700574	575275C91	USE	2513492			
18021310	USE	7700491	575277C91	USE	2513494			
18021311	USE	6700597	67135R93	USE	374750			
18021553	USE	6700598	67135R94	USE	374750			
18021824	USE	6700587	67212R91	USE	374230			
18021824	USE	6700587	68296R92	USE	374980			
18021896	USE	6700602	68296R93	USE	374980			
18021897	USE	6700614	77180R91	USE	374000			
18021897	USE	6700614	7EQ2005B	USE	374980			
18021970	USE	6700619						
18022004	USE	6700613						
18022072	USE	6700616						
18029871	USE	6700617						

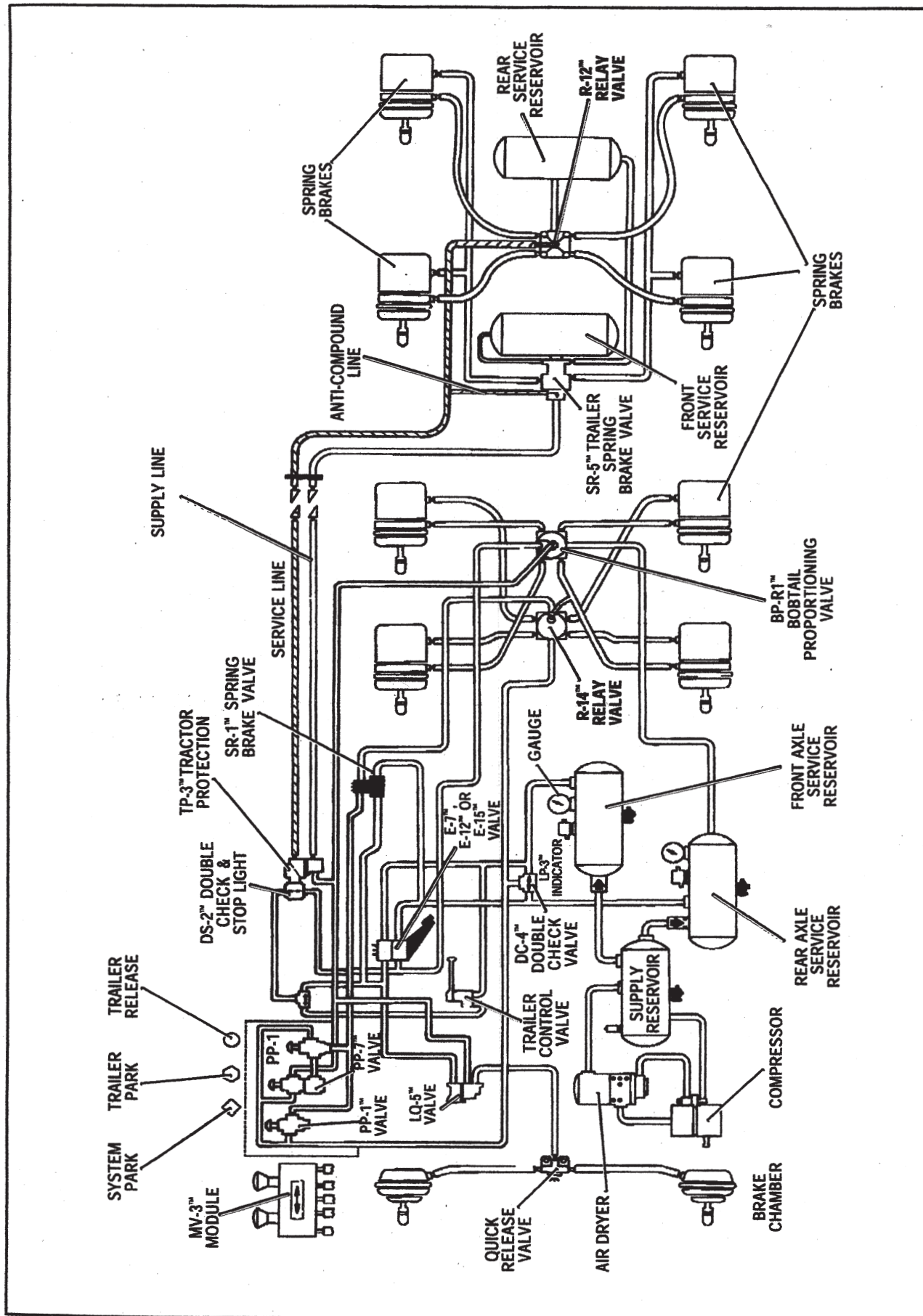

FIGURE 3 - TYPICAL PIPING SCHEMATIC

# *Prior*

HEAVY DUTY & MEDIUM DUTY  
BRAKE PRODUCTS



PRIOR AUTOMOTIVE PRODUCTS, LLC

[www.priorautomotive.com](http://www.priorautomotive.com)